

# Operating Manual

---

## ***Micro Lynx***

*System Unit with  
Keyboard Controller*

## Assistance and Information

### TimeLine

1755 La Costa Meadows Drive  
Suite B  
San Marcos, CA 92069

### Technical Support

Phone: (760) 761-4440  
Fax: (760) 761-4449  
SUPPORT@TIMELINEVISTA.COM

### Software Version

KBD
CP
MC

### Serial Number

--

Technical Assistance is available *ONLY* if the Micro Lynx is registered. Mail in your Warranty Card immediately to register the Micro Lynx.

**Remember**, when calling for technical support, you must provide the software version and Micro Lynx serial number so that we can give you accurate and prompt assistance.

## Printing History

All rights reserved. No part of this publication may be reproduced, stored in a retrieval system, or transmitted, in any form, or by any means electronically, mechanical, photocopying, recording or otherwise, without the prior written permission of TimeLine Vista, Inc.

Each revision will cause the letter to the right of the manual part number to change. The purpose for each revision will be listed below. Events such as the addition of a feature or functional test will cause the revision number to change.

Internal Document Number: 73K014 Revision M

Revision	Approval Date	Serial No. Affected	Changes Made
D	8/25/92	N/A	Added SMPTE Made Simple to Appendix
E	2/2/93	N/A	Moved Error Messages to Section 5, updated Setting an Offset in Section 4 and miscellaneous editing changes.
F	5/10/93	N/A	Software upgrade adding more features in Keyboard Controller Section. Operational Features Section and Index added. Other miscellaneous changes.
G	7/23/93	N/A	Update Advanced Features Section (Pro Tools) to include VITC, revise VITC Option Card Section, and miscellaneous editing changes
H	1/27/93	1024 or higher	Updated Option Cards Section to reflect card installation in new metal work. Updated TOC and Index accordingly.
I	2/22/94	N/A	Updated all Setup Menu tables, added Code Only Master in Operational Features section, Key Combinations in Appendix, and minor editing throughout. Updated TOC and Index accordingly.
J	3/1/95	N/A	Complete revision with software upgrade 1.34. TOC and Index updated accordingly.
K	8/1/95	N/A	Advanced Features (Using Mediasound with the Micro Lynx) and Appendix (SMPTE Made Simple) revised. TOC and Index updated accordingly.
L	6/1/96	N/A	Added FCC Notice. Update cable reference data
M	5/9/97	N/A	Remove FCC Notice.

## Limited Warranty

TimeLine Vista, Inc. (TimeLine) warrants this product against defects in material or workmanship as follows:

1. For a period of ninety (90) days from the date of purchase TimeLine will at it's option, either perform necessary repairs at it's expense or pay the labor charges of others it authorizes to repair the defective product. After the initial 90 day period labor charges are the responsibility of the purchaser.
2. In addition TimeLine will supply at no charge, new or rebuilt replacements for defective parts for a period of one (1) year from the date of purchase.

## Labor and Parts

To obtain warranty service, the purchaser must notify TimeLine in writing during the initial ninety (90) day period. TimeLine will then authorize the purchaser to take or deliver, prepaid, the product to TimeLine or it's authorized Service Center.

## Parts Only

During the remainder of the warranty period, any defective part will be replaced if the purchaser will take or deliver the product, prepaid to TimeLine. Labor incurred in the repair is at the purchaser's expense.

This Warranty does not cover any damage due to accident, misuse, abuse, or negligence.

We suggest that the purchaser retain the dated sales receipt as evidence of the original date of purchase. This warranty is not transferable and applies only to the original, registered purchaser.

REPAIR OR REPLACEMENT AS PROVIDED UNDER THIS WARRANTY IS THE EXCLUSIVE REMEDY OF THE PURCHASER. TIMELINE SHALL NOT BE LIABLE FOR BREACH OF ANY EXPRESS OR IMPLIED WARRANTY ON THIS PRODUCT, EXCEPT TO THE EXTENT PROHIBITED BY APPLICABLE LAW, AND EXCEPT FOR THE LIMITED WARRANTY DESCRIBED ABOVE. TIMELINE EXPRESSLY DISCLAIMS ANY WARRANTY, EXPRESS OR IMPLIED, OF MERCHANTABILITY OR FITNESS FOR A PARTICULAR PURPOSE.

USA: Some states do not allow the exclusion or limitation of incidental or consequential damages, or allow limitations on how long an implied warranty lasts, so the above limitation and exclusions may not apply to you. This warranty gives you specific legal rights and you may also have other rights that vary from state to state.

## Safety

To assist identification of potentially hazardous circumstances or procedures, warnings and cautions will be displayed with the appropriate text. Occasionally, information that provides an enhanced understanding of the text will be provided as a Note.

**Note:** A Note provides information about or an explanation of a topic related to the subject being discussed.

---

### *Warning*

Warnings describe a procedure that if not followed as specified could potentially cause damage to the equipment, a loss of data, or create an error condition.

---

## Manual Contents and Use

This manual starts with information that is used most frequently and moves to less frequently used information. To use the manual effectively, first review the applications and system configurations presented in the Applications chapter to determine your requirements and preferences.

Then use the Installation chapter to install the Micro Lynx and make the correct equipment connections. Follow the initialization and start up tutorial described in the Getting Started chapter to get a “hands-on” demonstration of the Micro Lynx capabilities.

If you experience any difficulties, refer to the Troubleshooting chapter to analyze the problem. Refer to the subsequent chapters for detailed information about each of the Micro Lynx functions.

- |                        |  |
|------------------------|--|
| <b>Introduction</b>    | Provides a high level overview of the Micro Lynx system and a broad feature list.                |
| <b>Applications</b>    | Presents common applications and configurations for Micro Lynx, audio, video and MIDI equipment. |
| <b>Installation</b>    | Describes how to install and configure the Micro Lynx system for your specific application.      |
| <b>Getting Started</b> | Presents initialization, start up procedures, and basic operating instructions.                  |
| <b>Troubleshooting</b> | An alphabetic list of error messages that may be displayed, including the cause and solution.    |

<b>Operational Features</b>	Contains a description of the basic operational features of the Micro Lynx.
<b>System Unit</b>	Provides a detailed description of the Micro Lynx System Unit front panel LEDs and back panel connectors.
<b>Keyboard Controller</b>	Provides a detailed description of the Keys, LEDs, Display and operating information for the Micro Lynx Keyboard Controller.
<b>Advanced Features</b>	Provides detailed operating information for some advanced synchronization applications.
<b>Option Cards</b>	Provides information on the Micro Lynx Option Cards.
<b>Appendix</b>	Provides miscellaneous information to help you setup or use your Micro Lynx.
	<b>SMPTE Made Simple</b> Provides basic information and various applications using SMPTE time code.
	<b>Quick Reference Guide</b> A graphical chart of the Micro Lynx Setup options.
	<b>Cable Reference Guide</b> Provides setup and cabling information to help you configure and use the Micro Lynx.
	<b>Auto Serial Transport Table</b> Contains a list of the serially controlled transports currently recognized by the transport menu setting AUTO Serial TRANSPORT.
	<b>Key Combination Guide</b> Provides Key and Key Combination Identification Numbers for “stuck key” errors.
	<b>Glossary</b> An alphabetic list of terms used during the discussion of the Micro Lynx.

## Conventions Used for Examples

This manual uses the following conventions.

- Press** Press a key, generally a movement key or function key such as [CLR].
- Select** Press or adjust the indicated key or wheel to obtain a result or display

- You see** A key word, indicator, or number that you can see on the front panel or display.
- [CLR]** This indicates a particular key on the Keyboard Controller, such as the clear key in this example.
- LED** This is one of the lights on the System Unit front panel or Keyboard Controller.
- Key** Each of the buttons, switches or keys on the Keyboard Controller that you press to cause something to happen.
- Display** The 80-character alphanumeric LCD display. In examples, the display will be illustrated by a double box.

A*B+	A→ 1:00:20:00 LL
>L>L	0





# Table of Contents

---

<b>Chapter 1 Introduction</b> .....	<b>1-1</b>
What is the Micro Lynx?.....	1-1
System Components.....	1-2
Options .....	1-2
System Configuration.....	1-3
Keyboard Controller.....	1-3
System Unit.....	1-3
Features .....	1-4
Micro Lynx Keyboard Controller (KBD).....	1-4
Micro Lynx System Unit (SU) .....	1-4
Specifications .....	1-6
Keyboard .....	1-6
System Unit.....	1-6
Time Code Generator .....	1-6
Synchronizer.....	1-6
Transports .....	1-7
Time Code Reader .....	1-7
Aux Inputs.....	1-7
Aux Outputs .....	1-7
Video Input.....	1-7
Video Output .....	1-7
Serial In/Out.....	1-7
Power Supply Unit.....	1-8
Physical .....	1-8
Options .....	1-8
Cable Requirements.....	1-9
<b>Chapter 2 Applications</b> .....	<b>2-1</b>
Introduction .....	2-1
Related TimeLine Products .....	2-1
Third Machine Expansion Card (M3).....	2-1
Digital Audio Clock Generator Card (ACG) .....	2-1
Video Sync Generator Card (VSG) .....	2-2
VITC Reader Card (VITC) .....	2-2
Basic Micro Lynx .....	2-3

## Table of Contents

---

Micro Lynx with a VTR .....	2-4
Micro Lynx with MIDI.....	2-5
Micro Lynx with Third Machine Card Installed.....	2-6
Micro Lynx with a Digital Audio Workstation .....	2-7
Micro Lynx with the Studio System.....	2-8
<b>Chapter 3 Installation.....</b>	<b>3-1</b>
Introduction .....	3-1
Hardware Supplied.....	3-1
System Setup Planning .....	3-1
Power.....	3-2
Fuses .....	3-3
Placement.....	3-3
Mount the System Unit (SU).....	3-3
Rack Mount Procedure .....	3-3
Cabling.....	3-4
Connect the Transports and the System Unit.....	3-5
Connect the Keyboard Controller Cables.....	3-7
Connect the AUX Input.....	3-8
Quick Test and Initialization Procedure.....	3-9
Quick Check Troubleshooting .....	3-13
<b>Chapter 4 Getting Started.....</b>	<b>4-1</b>
Introduction .....	4-1
Turn On and Initialization.....	4-1
Set the System Reference.....	4-5
Generate Time Code .....	4-7
Capture and Locate .....	4-9
Make a Group .....	4-10
Locking in a Group .....	4-11
Set an Offset .....	4-12
Trim an Offset .....	4-16
Change the Master Machine .....	4-17
Do an Edit.....	4-18
Reset the System .....	4-21
CLR.....	4-21
CLR + SYS .....	4-21

CLR + SETUP .....	4-21
CLR + TRAN .....	4-22
Customize the Micro Lynx Setup .....	4-23
Setup .....	4-24
<b>Chapter 5 Troubleshooting.....</b>	<b>5-1</b>
Introduction .....	5-1
System Error Messages .....	5-1
Self Test Messages.....	5-4
Error Messages .....	5-5
Warnings.....	5-6
Prompts.....	5-9
<b>Chapter 6 Operational Features .....</b>	<b>6-1</b>
Introduction .....	6-1
SMPTE Time Code Synchronization.....	6-2
Selecting Which Time Code Standard is Right for Your Application.....	6-2
SMPTE Time Code in the Audio-only Studio.....	6-3
Striping the Tape .....	6-4
SMPTE Time Code in the Integrated Video/Audio Production Studio.....	6-5
Recovering from Bad Time Code and Time Code Dropouts.....	6-6
Jam Sync Functions.....	6-8
Playback Features .....	6-8
Solo Mode - Single Machine Control Functions .....	6-8
Using Cue Points .....	6-9
Setting the Cue Register.....	6-9
Using the Cue Register .....	6-9
Group Mode - Multiple Machine Control .....	6-10
Create a Group.....	6-10
Changing the Master Machine .....	6-11
Resetting the Group.....	6-11
Machine Offsets .....	6-12
Setting the Offsets .....	6-12
Machine Control.....	6-12
Adjusting the PreRoll Time .....	6-13
Adjusting Postroll Time .....	6-13
How To Edit Loop a Group of Machines .....	6-13
Recording Functions .....	6-14
Using an Auxiliary Footswitch for Punch-In/Out Control.....	6-14

## Table of Contents

---

Setting Record Ready Options.....	6-14
Keyboard Operations.....	6-15
Using the Jog Wheel for Trim Operations .....	6-15
Using the Memory Registers .....	6-15
Storing Numbers in the Memory Registers .....	6-16
Recalling Memory Register Contents.....	6-16
Programming Macros.....	6-17
Deleting a Macro.....	6-18
Using the Preprogrammed Macros .....	6-18
Programming Your Own Macros.....	6-18
Program Macro: 0 - - 4 5 6 7 - -.....	6-19
Setting Variable Speed Playback .....	6-19
Code Only Master Operation .....	6-20
Selecting the System Reference .....	6-20
Setting the Master Machine Type.....	6-20
Transport Control .....	6-21
<b>Chapter 7 System Unit.....</b>	<b>7-1</b>
Introduction .....	7-1
Front Panel Indicators and Switches.....	7-2
OPTIONS .....	7-2
MIDI.....	7-2
EXTERNAL COMPUTER .....	7-2
KEYBOARD.....	7-2
SYSTEM.....	7-3
POWER .....	7-3
Video Reference .....	7-3
Transport Connectors.....	7-4
Time Code Readers and Generator .....	7-5
MIDI.....	7-6
Computer .....	7-7
System Tally, Aux In, Aux Out .....	7-9
Third Machine Interface.....	7-11
Audio Clock Generator .....	7-12
VITC.....	7-13
Power.....	7-13
<b>Chapter 8 Keyboard Controller .....</b>	<b>8-1</b>
Introduction .....	8-1

Display .....	8-4
Normal Operating Display.....	8-6
Calculator Display.....	8-7
Register Contents.....	8-8
Setup Display .....	8-9
Prompt & Error Display .....	8-10
Transport Controls.....	8-11
Jog/Shuttle .....	8-16
Jog/Shuttle Wheel .....	8-16
TRIM/LAST .....	8-16
JOG/NEXT .....	8-17
SHTL/ENTR.....	8-17
Device Select Keys .....	8-18
SETUP.....	8-19
Group Select Keys.....	8-28
A-C, TCG, MIDI .....	8-28
Solo Mode .....	8-28
Group Mode .....	8-29
LOCK LED .....	8-29
BUSY LED .....	8-29
REC LED.....	8-29
TCG.....	8-31
MIDI .....	8-32
GRP (GROUP).....	8-36
SOLO .....	8-36
LOOP .....	8-37
RDY .....	8-37
TRKS .....	8-37
Calculator Keys.....	8-41
00 .....	8-41
CLR.....	8-41
0 TIME/VID.....	8-43
1 PRE/A1 .....	8-44
2 POST/A2 .....	8-44
3 REF/A3 .....	8-45
4 SYNC/P/A4 .....	8-45
5 OFST/CUE.....	8-47
6 ERR/TC.....	8-49
7 IN.....	8-50
8 OUT .....	8-50

## Table of Contents

---

9 DUR/ASM.....	8-50
Auxiliary Function Keys.....	8-52
RCL.....	8-52
STO.....	8-53
MACRO .....	8-54
CAPT .....	8-55
= (equal) .....	8-56
+ (plus).....	8-56
- (minus) .....	8-57
SUBFR .....	8-59
Status Indicators .....	8-60
System.....	8-60
Digital Audio Clock Generator LEDs.....	8-62
<b>Chapter 9 Advanced Features.....</b>	<b>9-1</b>
Using AVID AudioVision with the Micro Lynx .....	9-1
To Control One Transport Device with the Micro Lynx .....	9-2
To Control Multiple Transport Devices with the Micro Lynx .....	9-3
To Slave AudioVision from an External Deck Connected to the Micro Lynx .....	9-3
Using Pro Tools with the Micro Lynx .....	9-4
Introduction .....	9-4
System Set Up And Configuration: Pro Tools as Slave .....	9-5
VITC Option Card Setup and Configuration for Pro Tools .....	9-8
System Setup And Configuration: Pro Tools as Master .....	9-9
Advanced MIDI Features .....	9-11
General Features .....	9-11
MIDI Setup Menu .....	9-11
Description Of Settings.....	9-12
Other Setting Descriptions.....	9-14
Using Mediasound with the Micro Lynx.....	9-15
Introduction .....	9-15
Micro Lynx Options Necessary for Video Sync .....	9-15
Using Mediasound with the Micro Lynx.....	9-16
Micro Lynx to Computer Connections.....	9-18
Micro Lynx to VTR Connections (Typical) .....	9-19
Micro Lynx Setup.....	9-20
Audio Clock Generator Setup.....	9-20
MIDI Time Code Setup.....	9-21
MIDI Data Source Setup .....	9-22
System Reference Setup .....	9-22

Time Code Generator Setup .....	9-23
Micro Lynx Operation.....	9-24
Controlling Mediasound with the Micro Lynx .....	9-24
Controlling One Transport Device with the Micro Lynx .....	9-25
<b>Chapter 10 Option Cards.....</b>	<b>10-1</b>
Video Sync Generator (VSG) Card .....	10-2
Installation Procedure .....	10-2
M3 Option Card .....	10-4
Transport Options.....	10-4
M3 Card Initialization Procedure.....	10-7
Installation Instructions .....	10-8
Digital Audio Clock Generator Card (ACG).....	10-12
Speed Reference .....	10-12
The ACG Solution .....	10-12
ACG-1 Features.....	10-13
ACG-2 Features.....	10-14
Operation.....	10-15
Setup Options.....	10-16
Digital Audio Clock Generator LEDs .....	10-17
Audio Clock Generator Outputs .....	10-19
ACG Card Setup.....	10-20
Error Conditions .....	10-21
Installation Instructions .....	10-21
VITC Reader Card .....	10-27
Features.....	10-27
Introduction.....	10-27
Installation Instructions .....	10-28
Operation Instructions.....	10-31
[F3] VITC Options.....	10-32
VITC Display and Status.....	10-32
<b>Appendix A .....</b>	<b>A-1</b>
Introduction .....	A-1
SMPTE Made Simple.....	A-1
Introduction.....	A-3
Why SMPTE? .....	A-3
What Can You Do with SMPTE?.....	A-3
Synchronizing Multiple Audio Machines .....	A-4
Locking to Picture .....	A-5

## Table of Contents

---

Mix Automation and More.....	A-5
Complete Systems.....	A-6
How Does SMPTE Do It?.....	A-7
What You Can Do with a Speed Reference.....	A-7
SMPTE: What You Can Do with a Speed and Position Reference.....	A-8
Anatomy of a SMPTE Frame.....	A-9
Time Code Formats.....	A-10
National Television Standards Committee (NTSC).....	A-10
Phase Alternate Line (PAL).....	A-10
Drop Frame (DF).....	A-10
Film.....	A-11
Different Frame Rate Formats.....	A-11
VITC.....	A-12
SMPTE, MIDI and MTC.....	A-13
Using SMPTE.....	A-14
Things To Know About Generating Time Code.....	A-14
Reshaping Time Code.....	A-15
Regeneration or Jam Sync.....	A-16
About Time Code Readers.....	A-16
Synchronizer Essentials.....	A-16
Phase or Sync Lock.....	A-17
Advanced Applications.....	A-17
Video Editing.....	A-17
Audio-For-Video.....	A-18
The Modern Electronic Recording Studio.....	A-20
SMPTE and the Digital Audio Workstation.....	A-21
The SMPTE Future.....	A-22
Setup Quick Reference.....	A-23
Cable Reference Guide.....	A-27
Key and Key Combination Identification Numbers.....	A-31
Glossary.....	A33
<b>Index.....</b>	<b>Index-1</b>
List of Figures.....	xv
List of Tables.....	xvii

## List of Figures

Figure Chapter 1 -1. Micro Lynx.....	1-1
Figure Chapter 1 -2. System Block Diagram.....	1-2
Figure Chapter 2 -1. Basic Micro Lynx.....	2-3
Figure Chapter 2 -2. Micro Lynx with a VTR.....	2-4
Figure Chapter 2 -3. Micro Lynx with MIDI .....	2-5
Figure Chapter 2 -4. Micro Lynx with Third Machine Card Installed .....	2-6
Figure Chapter 2 -5. Micro Lynx with a Digital Audio Workstation.....	2-7
Figure Chapter 2 -6. Micro Lynx with the Studio System .....	2-8
Figure Chapter 3 -1. Power Supply Connection .....	3-2
Figure Chapter 3 -2. Connect the Transports to the System Unit.....	3-5
Figure Chapter 3 -3. Micro Lynx System Unit to Keyboard Controller Connection.....	3-7
Figure Chapter 3 -4. Micro Lynx Keyboard Controller to Foot Switch.....	3-8
Figure Chapter 7 -1. System Unit.....	7-1
Figure Chapter 7 -2. Front Panel Indicators and Switches .....	7-2
Figure Chapter 7 -3. Video Reference .....	7-3
Figure Chapter 7 -4. Transport Connectors.....	7-4
Figure Chapter 7 -5. Time Code Readers and Generator.....	7-5
Figure Chapter 7 -6. MIDI .....	7-6
Figure Chapter 7 -7. External Control Interface.....	7-7
Figure Chapter 7 -8. System Tally and Aux Jacks.....	7-9
Figure Chapter 7 -9. Third Machine Interface .....	7-11
Figure Chapter 7 -10. Audio Clock Generator.....	7-12
Figure Chapter 7 -11. VITC Interface.....	7-13
Figure Chapter 7 -12. Power .....	7-13
Figure Chapter 8 -1. Front Panel.....	8-1
Figure Chapter 8 -2. Keyboard Key Locator.....	8-2
Figure Chapter 8 -3. Display.....	8-4
Figure Chapter 8 -4. Motion Control Keys .....	8-11
Figure Chapter 8 -5. Jog/Shuttle.....	8-16
Figure Chapter 8 -6. Device Select Keys.....	8-18
Figure Chapter 8 -7. Group Select Keys .....	8-28
Figure Chapter 8 -8. Calculator Keys .....	8-39
Figure Chapter 8 -9. Auxiliary Function Keys .....	8-50

## Table of Contents

---

Figure Chapter 8 -10. Status Indicator .....	8-58
Figure Chapter 9 -1. MIDI Routing .....	9-13
Figure Chapter 9 -2. Micro Lynx with an SGI Workstation .....	9-17
Figure Chapter 9 -3. Micro Lynx to SGI Workstation Connections.....	9-18
Figure Chapter 9 -4. Micro Lynx to VTR Connections.....	9-19
Figure Chapter 10 -1. Video Sync Generator Card .....	10-3
Figure Chapter 10 -2. Remove the Support Bracket.....	10-8
Figure Chapter 10 -3. Install the Option Card Bracket.....	10-9
Figure Chapter 10 -4. Installation of M3 Card.....	10-9
Figure Chapter 10 -5. Installation of M3 Card.....	10-10
Figure Chapter 10 -6. ACG Block Diagram.....	10-13
Figure Chapter 10 -7. Audio Clock Generator Inputs/Outputs .....	10-19
Figure Chapter 10 -8. Remove Support Bracket .....	10-22
Figure Chapter 10 -9. Install the Option Card Bracket.....	10-22
Figure Chapter 10 -10. Option Cable Installation .....	10-23
Figure Chapter 10 -11. Installation of the ACG Card.....	10-24
Figure Chapter 10 -12. Relocation of “L” Bracket .....	10-25
Figure Chapter 10 -13. Install the ACG Option Card Bracket.....	10-25
Figure Chapter 10 -14. Install the ACG Card .....	10-26
Figure Chapter 10 -15. Remove the Support Bracket.....	10-28
Figure Chapter 10 -16. Install the Option Card Bracket.....	10-29
Figure Chapter 10 -17. Securing the VITC Card .....	10-29
Figure Chapter 10 -18. Securing the VITC Card .....	10-31
Figure Appendix A-1. Basic SMPTE Time Code Setup.....	A-4
Figure Appendix A-2. Synchronize to Video.....	A-5
Figure Appendix A-3. MIDI Sequencer and Time Code.....	A-6
Figure Appendix A-4. Complete Studio System .....	A-6
Figure Appendix A-5. Two Sine Wave Signals in Phase.....	A-8
Figure Appendix A-6. Time Code Address.....	A-9
Figure Appendix A-7. Video Tape and VITC Time Code.....	A-12
Figure Appendix A-8. Reshaping Time Code.....	A-15
Figure Appendix A-9. Jam Sync .....	A-16
Figure Appendix A-10. Automated Mixing System.....	A-19
Figure Appendix A-11. The “Modern” Electronic Studio .....	A-20
Figure Appendix A-12. Micro Lynx with a Digital Audio Workstation .....	A-21

## List of Tables

Table Chapter 1 -1. Cable Requirements.....	1-9
Table Chapter 3 -1. Cable Requirements.....	3-4
Table Chapter 3 -2. Cable Check List .....	3-6
Table Chapter 3 -3. AUX Connector Pin Description.....	3-8
Table Chapter 3 -4. Troubleshooting the System Unit.....	3-13
Table Chapter 3 -5. Troubleshooting the System Unit communications with the Keyboard Controller.....	3-13
Table Chapter 3 -6. Troubleshooting the Micro Lynx communications with the machines..	3-13
Table Chapter 4 -1. TCG Options Menu .....	4-5
Table Chapter 4 -2. Micro Lynx Setup Menu .....	4-24
Table Chapter 4 -3. Micro Lynx Setup Selections .....	4-25
Table Chapter 7 -1. Transport Connector Pin Description .....	7-4
Table Chapter 7 -2. RDR 1 Time Code Connector Pin Description.....	7-5
Table Chapter 7 -3. RDR 2 Time Code Connector Pin Description.....	7-5
Table Chapter 7 -4. Time Code OUT Connector Pin Description .....	7-5
Table Chapter 7 -5. MIDI IN Connector Pin Description.....	7-6
Table Chapter 7 -6. MIDI OUT Connector Pin Description.....	7-6
Table Chapter 7 -7. MIDI THRU/OUT Connector Pin Description .....	7-6
Table Chapter 7 -8. I/F Connector Pin Description .....	7-7
Table Chapter 7 -9. I/F Connector Pin Description .....	7-7
Table Chapter 7 -10. RS232/422 Connector Pin Description .....	7-8
Table Chapter 7 -11. Keyboard Connector Pin Description .....	7-8
Table Chapter 7 -12. System Tally Connector Pin Description .....	7-9
Table Chapter 7 -13. Aux In Connector Pin Description.....	7-9
Table Chapter 7 -14. Aux Out Connector Pin Description.....	7-10
Table Chapter 7 -15. Transport 3 Connector Pin Description .....	7-11
Table Chapter 7 -16. AES/EBU Connector Pin Description.....	7-12
Table Chapter 7 -17. POWER Connector Pin Description .....	7-13
Table Chapter 8 -1. Key Mnemonics .....	8-3
Table Chapter 8 -2. Setup Key Description .....	8-19
Table Chapter 8 -3. ACG Setup Menu .....	8-20
Table Chapter 8 -4. F3 Setup Menu.....	8-20

## Table of Contents

---

Table Chapter 8 -5. SYS Setup Menu.....	8-21
Table Chapter 8 -6. TRAN Setup Menu.....	8-23
Table Chapter 8 -7. EVENT Setup Menu.....	8-26
Table Chapter 8 -8. MEM Setup Menu.....	8-27
Table Chapter 8 -9. TCG Setup Menu.....	8-30
Table Chapter 8 -10. GRP Setup Menu.....	8-31
Table Chapter 8 -11. LOOP Setup Menu.....	8-34
Table Chapter 8 -12. RDY Setup Menu.....	8-35
Table Chapter 8 -13. TRKS Setup Menu.....	8-38
Table Chapter 8 -14. Error Register.....	8-47
Table Chapter 9 -1. Micro Lynx MIDI Setup Selections.....	9-11
Table Chapter 10 -1. TRAN Setup Options.....	10-5
Table Chapter 10 -2. Troubleshooting the M3 Card.....	10-7
Table Chapter 10 -3. ACG Card Sample Rate Ratios.....	10-14
Table Chapter 10 -4. ACG Setup Options.....	10-16
Table Chapter 10 -5. AES/EBU Connector Pin Description.....	10-19
Table Chapter 10 -6. Troubleshooting the ACG Card.....	10-20
Table Chapter 10 -7. F3 Setup Options.....	10-32
Table Appendix A-1. Frame Rate Formats.....	A-11
Table Appendix A-2. Setup Quick Reference Guide.....	A-23
Table Appendix A-3. Cable Reference Guide.....	A-25

# Chapter 1 Introduction

---

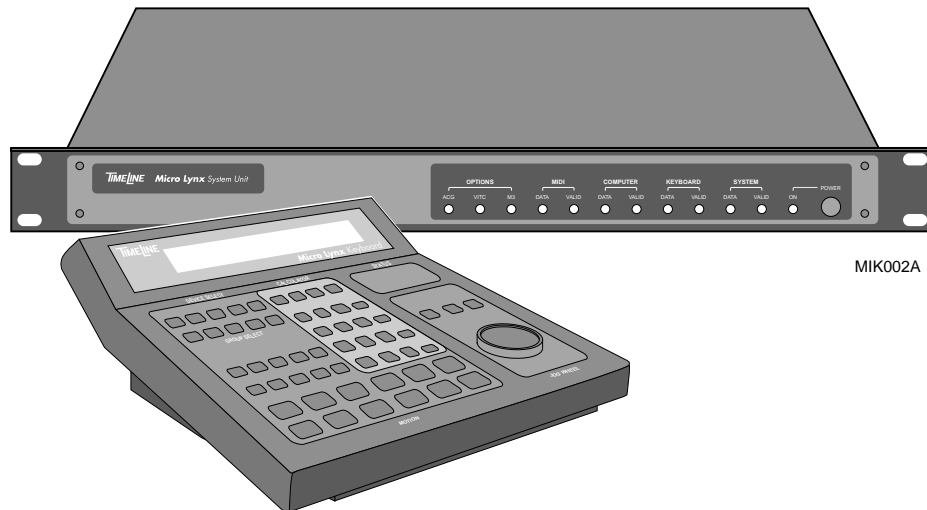

**Figure Chapter 1 -1. Micro Lynx**

## What is the Micro Lynx?

The Micro Lynx is a high performance, integrated machine control system. The Micro Lynx system was specifically designed to handle the ever increasing machine control and synchronization requirements of the project recording studio and smaller post production facility.

The Micro Lynx is a comprehensive two machine synchronizer which may be optionally expanded to three machines. The full feature Keyboard Controller provides the interface for SMPTE and MIDI time codegeneration, transport synchronizer operations, track enable, automated edit, and events control. The Micro Lynx system has two main components and four option cards:

## System Components

Micro Lynx Keyboard Controller (KBD)  
Micro Lynx System Unit (SU)

## Options

- M3** Machine Expansion Card to add a third transport
- ACG** Synchronized digital audio sampling clock interface. The clock card outputs digital audio sample rate clocks that are synchronized to the system reference.
- VSG** Video Sync Generator for NTSC or PAL composite sync generation
- VITC** VITC Reader Card

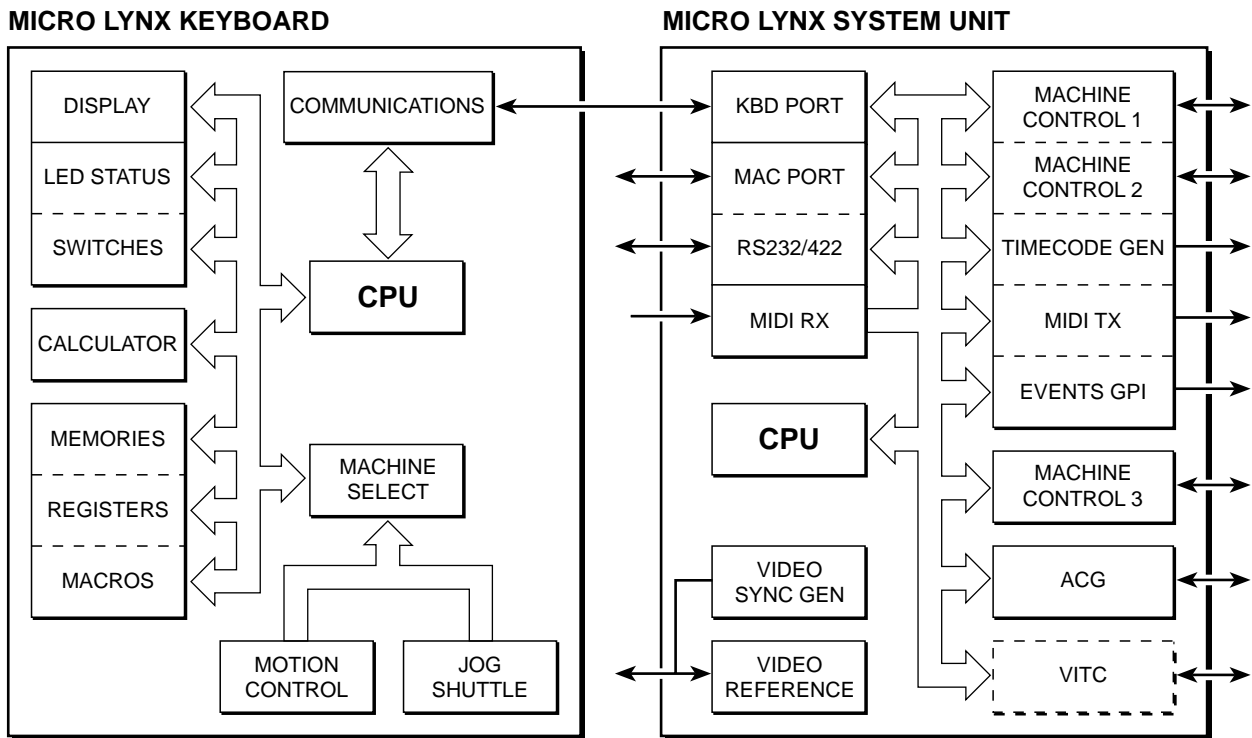

MIK001A

Figure Chapter 1 -2. System Block Diagram

---

## System Configuration

The smaller recording studio requires an integrated system that works with both SMPTE and MIDI. Major studios and post-production houses require exacting performance specifications, long-term durability, and technical support. Micro Lynx not only meets these requirements, but also offers easy installation, guaranteed system compatibility, and cost-effectiveness for a complete system solution.

### Keyboard Controller

The Keyboard Controller allows remote control of up to three machines plus generation of locked SMPTE and MIDI time codes. Editing and control commands are entered on the keyboard. Time code status and register contents appear on the 80-character LCD display.

The Keyboard Controller serially communicates command and system status information to the System Unit over a telephone type cable.

### System Unit

The System Unit has wideband, high speed, 1/10 to 60x play speed, bi-directional time code readers and a multi-standard time code generator. There are two machine controller/synchronizers with software parameter selection for over 120 different transport types, MAC and IBM computer control ports, MIDI ports, GPI and mute relays, and system status outputs. Setup menus provide convenient user access to configure the system for specific applications.

## Features

### Micro Lynx Keyboard Controller (KBD)

- Independent CPU with battery backed-up RAM retains all time code and system setup data when powered down
- Menu-driven tape transport selection from the Keyboard
- Supports subframe offsets
- Full transport control of up to 3 audio and/or video transports
- Full editing capability with transport controls, keypad input and special function keys
- Solo or Group operation of transports or MIDI devices
- User selected master for group operations of audio or video transports and MIDI controlled devices
- Computer guided entry (prompts displayed for next entry)
- Direct entry and calculation of time code numbers
- Supports register store and recall operations
- 100 memory locations
- Shuttle wheel for shuttle and frame jog operations with VTRs and many ATRs
- Trim mode to trim time code register values (frames & subframes) using a wheel rather than the calculator
- Locate mode to position all selected transports to a specified time code minus preroll
- Programmable edit sequences with rehearse-in/out, record-in/out and replay
- Edit loop mode allowing a programmed edit sequence to be repeated indefinitely

### Micro Lynx System Unit (SU)

- Time Code Generator**
- Generates all world wide standards: SMPTE drop frame and non-drop frame, EBU, and Film
  - Reference sources: internal crystal, MIDI time code, external sync input, and digital audio clock
  - External sync reference input accepts black burst, or composite sync
  - Jam sync
  - Pilot field rate output (60, 59.94, 50, 48 Hz) locked to generator
- Time Code Reader**
- Two wideband, high speed readers (three with option card)

- 
- Automatically detects time code type
  - Supports both -10 dB and +4 dB input signal levels
  - 1/10 to 60x speed
  - Bi-directional
  - Reshaped time code output derived from the reader
- Synchronizer**
- Two transports plus full chase capability for MIDI
  - Supports over 120 different audio and video transports
  - Selectable master, independent of machine cabling, VTRs can be slaves
  - Select and set up transport from resident menus
  - No internal adjustments
  - Universal machine interface supports both master and slave operation
  - Supports parallel, serial, and combined machine interfaces
- MIDI**
- Synchronizes MIDI systems to ATR/VTRs
  - Converts SMPTE to MIDI Time Code (MTC)
  - Converts MTC to SMPTE, making MIDI the system master
  - In, out and thru/out MIDI jacks
  - DIN8 mini-circular connectors for direct Macintosh MIDI connection
- Outputs**
- Two programmable GPI relay closures
  - GPI relay modes:
    - Either GPI relay may be pulsed or latched
    - One GPI has dialog beep mode with menu selections for 3 or 4 beeps, beep spacing, and beep duration
  - Selectable Aux output- Reader 1, 2, 3 reshaped time code
    - Pilot output
    - ADR beep
  - System lock tally
- Computer Interface**
- EIA standard RS-232C or RS422 serial I/O
  - Computer control port allows communication with personal computers for full remote computer control

## Specifications

### Keyboard

Free Standing Display Type	80 character, back lit LCD
Keys	33 numeric function keys 12 transport control keys
Jog/Shuttle wheel	
Communications	RS422, 38.4 k baud asynchronous

### System Unit

Rack mount or free standing	
Communications:	
Keyboard	RS422, 38.4 k baud asynchronous
MIDI	31.25 k baud asynchronous

### Time Code Generator

Unbalanced Output	
Output Level	-1 dBm (1.4V pp)
Output Impedance	100 ohms
Signal Rise Time	4 microseconds
Time Code Stability	± 2 microseconds max.
Operating Code	SMPTE (30 FPS) SMPTE Drop Frame (30 FPS DF) EBU (25 FPS) Film Code (24 FPS)
Pilot Rate	60, 59.94, 50, 48 Hz (locked to generator)
Reference Sources	
Internal Crystal	30, 29.97, 25, 24
Timing Source	Crystal (±20 ppm)
External Video Input	30, 29.97 (NTSC), 25 (PAL) Black burst (.5V – 2.0V nominal) Composite sync (.5V – 8V p-p)

### Synchronizer

Lock Stability	<± 50 microseconds
Lock Time	2 – 3 seconds, nominal
Tach Frequency Range	4 – 2000 Hz nominal, playspeed
User Adjustment Required	None
Parallel Interfaces	Use TimeLine parallel cables (listed under Required Cables) Auto-configures from transport menus.
Serial Interfaces	Requires serial interface cable. Auto-configures from transport menus.

## Transports

Supports transports manufactured by:

AEG, Akai, Alesis, Ampex, Denon, Fostex, JVC, 3M, Mitsubishi, Otari, Panasonic, Saturn, Sony, Stellavox, Studer, Tascam

## Time Code Reader

Differential Input	
Signal Input Level	-20 to +10 dBm
Input Impedance	10 k ohms
Speed Range	1/10 to 60 x play speed
Bi-directional	
Automatic Detection of Time Code Type	
Reshape Output	

## Aux Inputs

Differential Input	
Input Impedance	10 k ohms

## Aux Outputs

Unbalanced Output	
Output Level	-1 dBm (1.4V pp)
Output Impedance	100 ohms

## Video Input

Differential Input	
Input Level	.5 V nominal to 8 V
Input Impedance	1 k ohms

## Video Output

Single-ended Output	
Output Level	-600 mV nominal, unterminated
Output Impedance	75 ohms

## Serial In/Out

Formats	RS422, RS232C
Connectors	Macintosh II Serial Interface (SCSI) 9-pin 'D' serial communications port

## Power Supply Unit

Power Supply Mains Input	100-250 VAC at 50/60 Hz, 15 W nominal, 30 W max.
Output	+5 V, 3A max -12 V, 3A max +12 V, 1.0A max

## Physical

Size	
Keyboard	3" H x 8.75" W x 7.5" D 8 cm H x 225 cm W x 190 cm D
System Unit	1.75" H x 19" W x 11.75" D 4.5 cm H x 485 cm W x 30 cm D
Weight	
Keyboard	1 lbs, 7 oz
System Unit	6 lbs, 0 oz
Mounting	
Keyboard	Free standing
System Unit	Supplied with mounting hardware for standard 19" rack

## Options

M3	Machine Expansion Card
ACG	Synchronized Digital Audio Sampling Clock Interface
VSG	Video Sync Generator for NTSC and PAL
VITC	VITC Reader

*TimeLine Vista, Inc reserves the right to change the design and specifications of equipment without notice.*

# Cable Requirements

Table Chapter 1 -1. Cable Requirements

## Keyboard Controller

Between Equipment	Connector	Supplied By	From/To
KBD to SU	8-pin RJ 45	TimeLine	Keyboard to System Unit

## System Unit

Between Equipment	Connector	Supplied By	From/To
SU to Power Supply	DIN-5	TimeLine	System Unit to Power Supply Unit
SU to Transports	40-pin	TimeLine	System Unit to each transport remote or synchronizer connector
SU and Transport time code inputs and outputs	1/4" stereo	<b>Customer</b>	System Unit RDR (1,2,3), OUT & Aux to Transport time code output, time code input and appropriate Aux transport inputs and outputs
SU to Ext Video	BNC	<b>Customer</b>	System Unit to Video Reference Sync source or VTR/DTR Video Sync input if TimeLine VSG option installed
SU to MIDI Equipment	DIN-5	<b>Customer</b>	System Unit MIDI In/Out or Thru/Out to Sequencer, Synthesizer, keyboard, or drum machine
SU to Macintosh Computer	MIN DIN-8	<b>Customer</b>	System Unit MAC I/F to Macintosh computer serial interface
SU to IBM Computer	9-pin, 'D'	<b>Customer</b>	System Unit Serial Computer Port to Ext control computer
SU to Studio	9-pin, 'D'	<b>Customer</b>	System Unit GPI, Mute and Lock to Console/Mon system
SU ACG to AES/EBU	9-pin, 'D'	<b>Customer</b>	System Unit ABS/EBU to Digital Audio Equipment I/O
SU ACG to Workstation	BNC	<b>Customer</b>	System Unit Word Clock & Oversample Clock outputs to Digital Audio Workstation or DTR
SU VITC to Video	BNC	<b>Customer</b>	System Unit to VTR output and Video Mon equipment input

# Chapter 2 Applications

---

## Introduction

Many different types of audio and video equipment are available. Before configuring the Micro Lynx decide what equipment you will use and how your system will be set up. We have selected some of the most common configurations used in the industry. Please use these as a guide for configuring your equipment to accommodate your specific application.

## Related TimeLine Products

When looking through this chapter, keep the Micro Lynx option cards in mind. TimeLine products can provide many solutions for your time code, controller system, and synchronization requirements.

### Third Machine Expansion Card (M3)

The Micro Lynx is designed to accommodate a third machine. To control an additional tape transport, simply plug this card into the System Unit to expand your system. The M3 card supports ATR, DTR, and VTR machines. The Sony VO-5850 requires the special interface circuitry in the M3 card for operation with the Micro Lynx.

### Digital Audio Clock Generator Card (ACG)

The Micro Lynx is designed to generate synchronized digital audio word clock to integrate a digital audio workstation into your system.

There are two variations of the ACG card. The ACG-1 provides Word Clock and Oversample Clock Outputs. The ACG-2 has the same features as ACG-1 and adds an AES/EBU Silent Output and an external clock input. It allows the AES/EBU and clock input signals to be used as a system reference.

## **Video Sync Generator Card (VSG)**

When synchronizing a system that includes VTR or DTR machines, the Micro Lynx and the machines must be referenced to a common video sync source. If you do not have an external sync pulse generator TimeLine's VSG card can be used as a system reference. This card generates both PAL and NTSC composite sync.

## **VITC Reader Card (VITC)**

The Micro Lynx System Unit is designed to accept a VITC reader card. When you synchronize a VTR that does not support serial time code a VITC reader card will permit frame accurate positioning in still or stop mode.

## Basic Micro Lynx

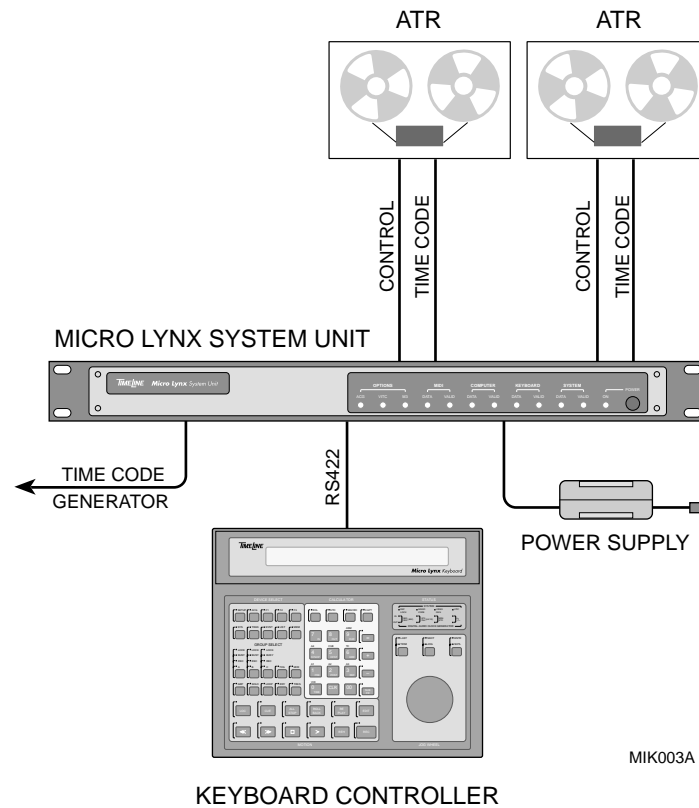

Figure Chapter 2 -1. Basic Micro Lynx

**Typical Uses** Micro Lynx adds multiple audio machine control and synchronization to a basic studio setup.

The Micro Lynx provides a fast, convenient way to perform time code reading, time code generation, and synchronization. It controls activities performed frequently such as locating, entering offsets, slipping one tape machine against another, and doing automated edits.

**Considerations** The Micro Lynx has transport selection of over 120 machines. The battery backup stores all setup parameters, so your studio configuration will never be lost.

# Micro Lynx with a VTR

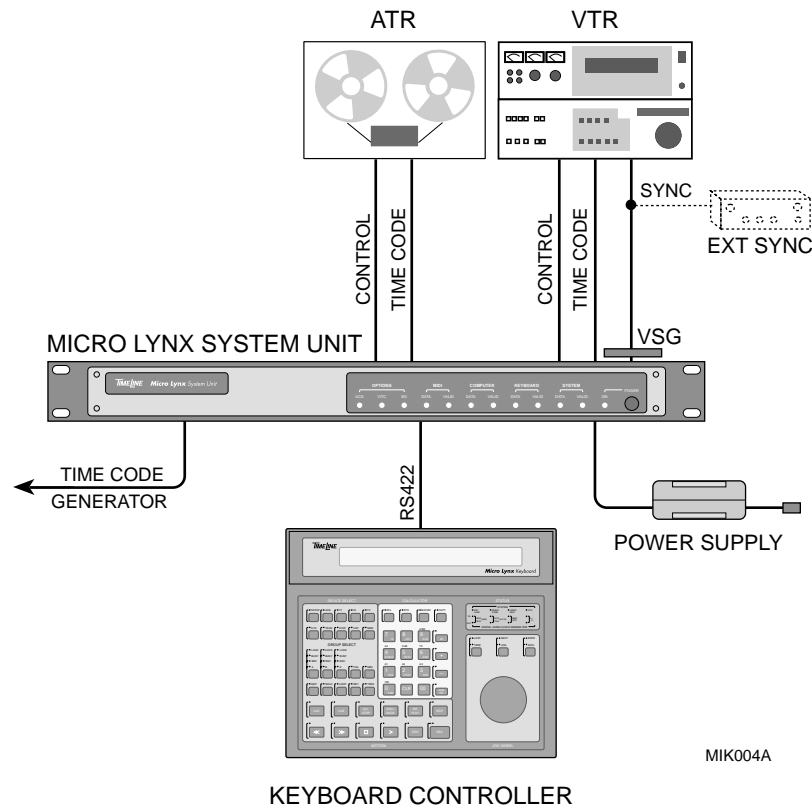

Figure Chapter 2 -2. Micro Lynx with a VTR

**Typical Uses** Audio for video.

The Micro Lynx is compatible with numerous video transports that support external synchronization including standard 3/4" U-matic, beta, S-VHS, VHS, open reel, and digital VTRs. With Micro Lynx the video machines are always resolved, so they can be run as either Master or Slave. If the VTR uses Sony Serial Protocol, serial time code can be used as the time code source.

**Considerations** Use an external video sync source as a speed reference source for the Micro Lynx and VTR. Install the Micro Lynx Video Sync Generator Card (VSG) if an external sync source is not available.

## Micro Lynx with MIDI

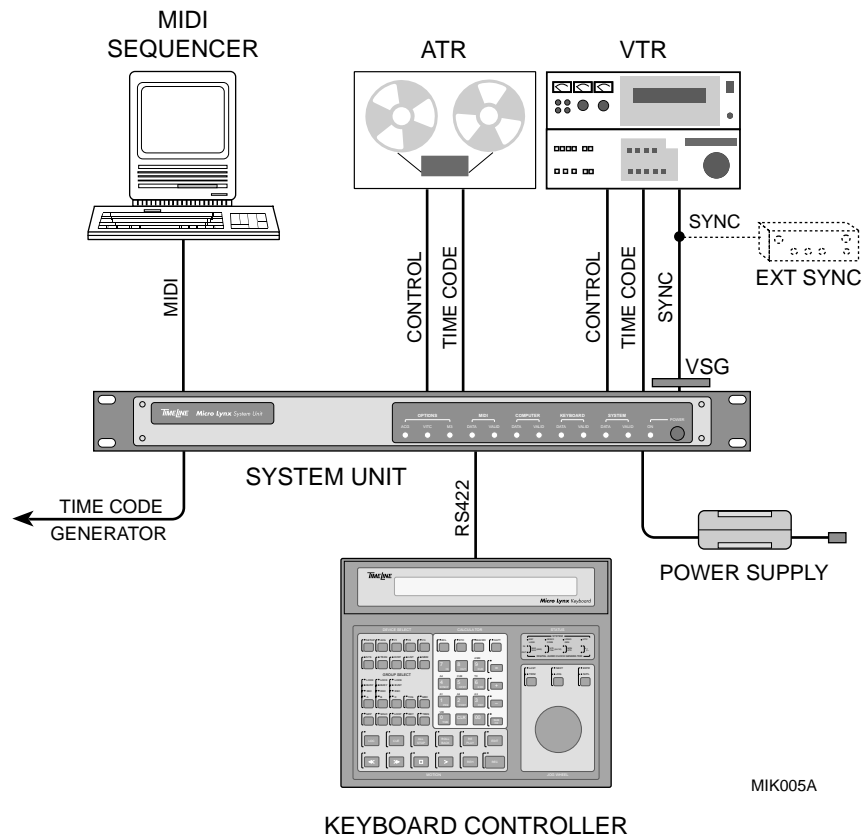

Figure Chapter 2 -3. Micro Lynx with MIDI

**Typical Uses** Use whenever MIDI and SMPTE must work together to produce music composition, sampled sound effects, or layup.

Micro Lynx has MIDI capabilities allowing a Sequencer or other MIDI device to be synchronized with the transports as Master or Slave.

**Considerations** Your MIDI device should have the ability to read and use MTC and/or SMPTE.

## Micro Lynx with Third Machine Card Installed

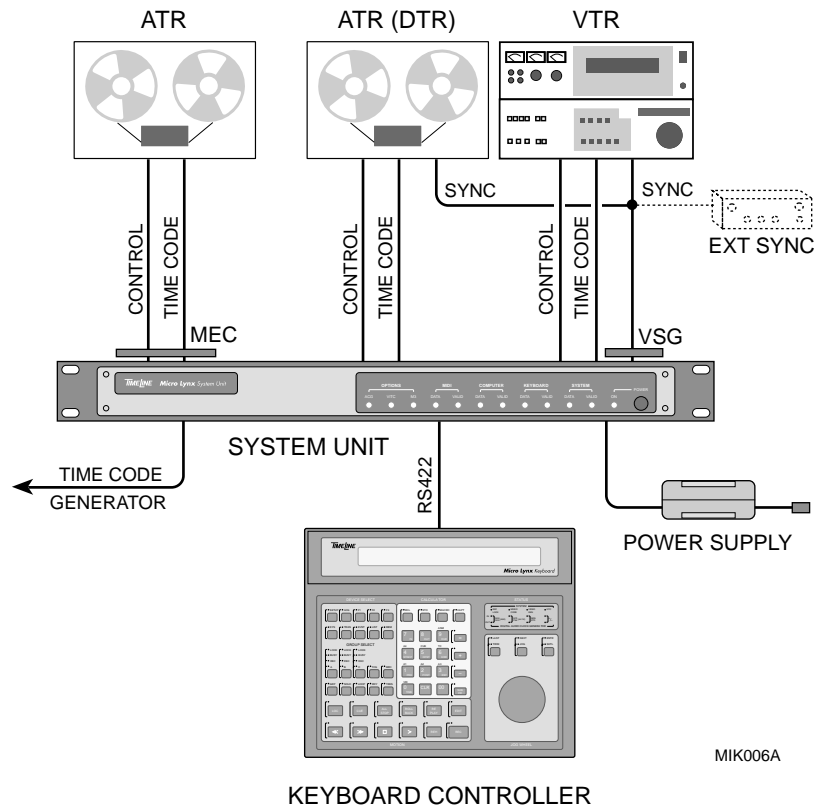

Figure Chapter 2 -4. Micro Lynx with Third Machine Card Installed

**Typical Uses** Multiple transport and audio post-production work.

Expands the Micro Lynx system to three transports; providing you with a larger system and greater flexibility. The Third Machine (M3) card also includes an interface for the Sony VO-5850.

**Considerations** The M3 card supports all transports and is required for interface with the Sony VO-5850. Install the Micro Lynx VSG card if an external video sync source is not available.

## Micro Lynx with a Digital Audio Workstation

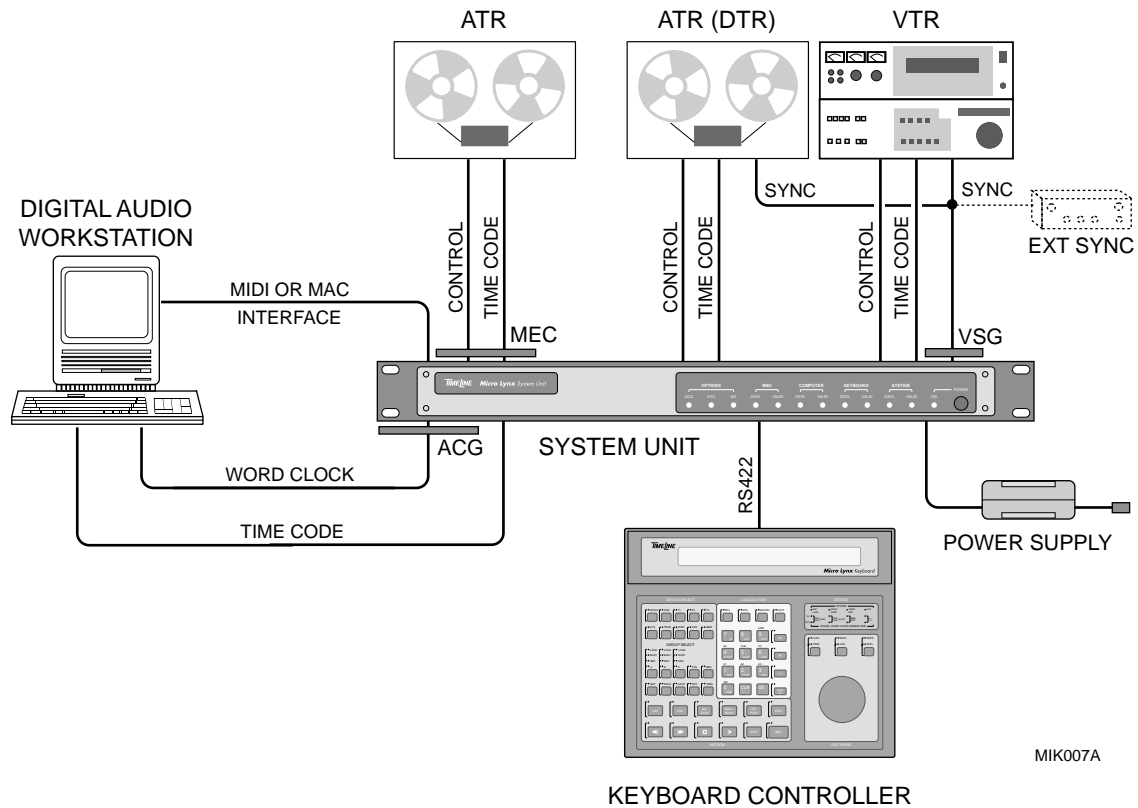

Figure Chapter 2 -5. Micro Lynx with a Digital Audio Workstation

**Typical Uses** Music composition post-production and Digital Audio Workstation.

With the Audio Clock Generator (ACG) card installed, the Micro Lynx can synchronize a Digital Audio Workstation with the rest of your system. Micro Lynx accomplishes this by providing the Digital Audio Workstation with word and oversample clocks locked to any of the available system references, including varispeed.

**Considerations** Your Digital Audio Workstation should be able to receive an external word or oversample clock.

## Micro Lynx with the Studio System

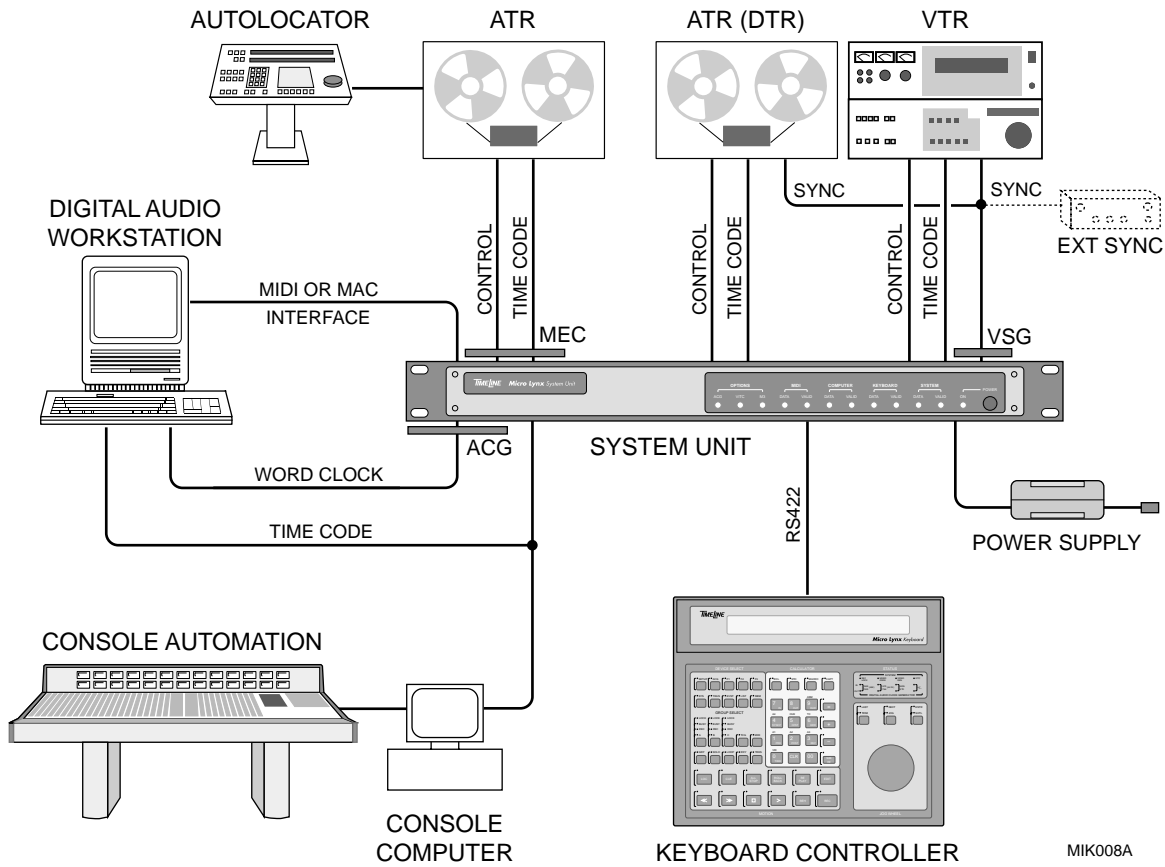

Figure Chapter 2 -6. Micro Lynx with the Studio System

**Typical Uses** Using the Micro Lynx to its full potential will give unparalleled control over your audio, video, MIDI, and console automation system. Because it is an integrated synchronization system, everything can be controlled from a single location - the Micro Lynx Keyboard Controller.

**Considerations** The Micro Lynx system is extremely flexible, but it is limited to three ATR/VTR transports plus the ACG, MIDI, and time code outputs.

# Chapter 3 Installation

---

## Introduction

This chapter will help you install the Micro Lynx system hardware. The first part of the chapter describes the different hardware elements. The second part of the chapter is an Installation Quick Check.

## Hardware Supplied

The Micro Lynx system includes the following items:

- 1 Keyboard Controller (KBD)
- 1 System Unit (SU)
- 1 KBD to SU Cable
- 1 AC to DC Power Supply

## System Setup Planning

Before you install and configure your equipment, there are several installation issues to consider and plan.

- Power** The Micro Lynx uses a DC power supply. Connect and use the power supply shipped with the Micro Lynx. The power supply should be plugged into a surge protected MAINS outlet.
- Placement** The System Unit is fitted with rack mount hardware and is generally installed in a 19" equipment rack. The Keyboard Controller has a rubber mat base and can be placed on a console, table or similar flat surface.
- Cabling** The Micro Lynx requires power, transport, time code and communications cables. Careful connection and routing of cables will ensure a quick and successful installation. Power supply and Keyboard cables are included with the Micro Lynx. You must order the correct transport control and time code cables with your Micro Lynx to complete an installation.
- Initialization** Power up the Micro Lynx, select the transport type settings and perform a quick check to verify correct system operation.

# Power

The Micro Lynx has an external power supply.

The Power Supply Unit is a switched mode type which automatically adjusts to the correct AC voltage for your area. It is suitable for operation at any voltage in any country.

USA, Japan      110-120 VAC  
Outside USA    220-250 VAC

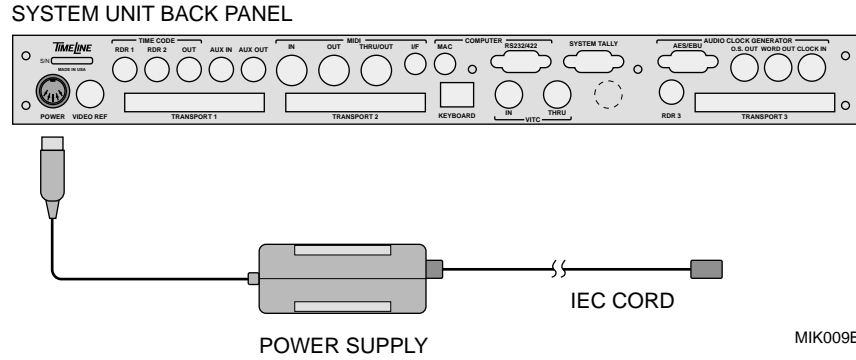

MIK009B

**Figure Chapter 3 -1. Power Supply Connection**

1. Insert the Power Supply Unit DIN type connector into the socket marked POWER on the back of the Micro Lynx as shown in Figure 3-1. Connect the Power Supply IEC cord to the AC supply.
2. Press the Power Switch on the System Unit front panel.
3. If the Power ON LED on the front panel lights, then there is power to the unit. If not, check the connections between the AC outlet and the System Unit.
4. After approximately three seconds, the SU system DATA and VALID LEDs should light.
5. Power down the unit.

---

## Fuses

The correct fuse is installed in the Power Supply by the factory. This fuse is not replaceable. If the Power Supply Unit should fail, contact your local dealer or TimeLine for a replacement unit.

## Placement

The System Unit and the Keyboard Controller are connected by a 25 foot cable.

## Mount the System Unit (SU)

The System Unit is designed as rack mount equipment. However, the top and bottom covers provide adequate protection for table top operation.

## Rack Mount Procedure

The System Unit is a standard 19" rack mount case. When deciding placement, provide adjacent mounting space for the Micro Lynx Power Supply Unit.

### Procedure

1. Slide the System Unit into a 1U high space in a 19" equipment rack.
2. Mount and secure the Micro Lynx Power Supply close to the System Unit.

---

### **Warning**

Do *NOT* add an extension to the 5-pin DIN cable between the Power Supply and the System Unit.

---

3. Insert the four mounting screws into the front panel of the System Unit and secure it to the equipment rack.
4. If required, use an AC MAINS (with ground) extension cable for the Power Supply Unit.

# Cabling

The Micro Lynx can control and synchronize an entire Studio system. Use the following table to determine what equipment will be connected to the Micro Lynx and to verify that the correct cables are available.

Cabling connections are critical. Bad or poorly routed cables are often the cause of installation problems. It is essential that the correct, high quality cables are used to ensure reliable and trouble-free operation.

**Table Chapter 3 -1. Cable Requirements**

**Keyboard Controller (KBD)**

Between Equipment	Connector	Supplied By	From/To
KBD to SU	8-pin RJ 45	TimeLine	Keyboard to System Unit

**System Unit (SU)**

Between Equipment	Connector	Supplied By	From/To
SU to Power Supply	DIN-5	TimeLine	System Unit to Power Supply Unit
SU to Transports	40-pin	TimeLine	System Unit to each transport remote or synchronizer connector
SU and Transport time code inputs and outputs	1/4" stereo	<b>Customer</b>	System Unit RDR (1,2,3), OUT & Aux to Transport time code output, time code input and appropriate Aux transport inputs and outputs
SU to EXT Video	BNC	<b>Customer</b>	System Unit to Video Reference Sync source or VTR/DTR Video Sync input if TimeLine VSG option installed
SU to MIDI equipment	DIN-5	<b>Customer</b>	System Unit MIDI In/Out or Thru/Out to Sequencer, Synthesizer, keyboard, or drum machine
SU to Macintosh Computer	MIN DIN-8	<b>Customer</b>	System Unit MAC I/F to Macintosh computer serial interface
SU to IBM Computer	9-pin, 'D'	<b>Customer</b>	System Unit Serial Computer Port to Ext control computer
SU to Studio	9-pin, 'D'	<b>Customer</b>	System Unit GPI, Mute and Lock to Console/Mon system
SU ACG to AES/EBU	9-pin, 'D'	<b>Customer</b>	System Unit ABS/EBU to Digital Audio Equipment I/O
SU ACG to Workstation	BNC	<b>Customer</b>	System Unit Word Clock & Oversample Clock outputs to Digital Audio Workstation or DTR
SU VITC to Video	BNC	<b>Customer</b>	System Unit to VTR output and Video Mon equipment input

## Connect the Transports and the System Unit

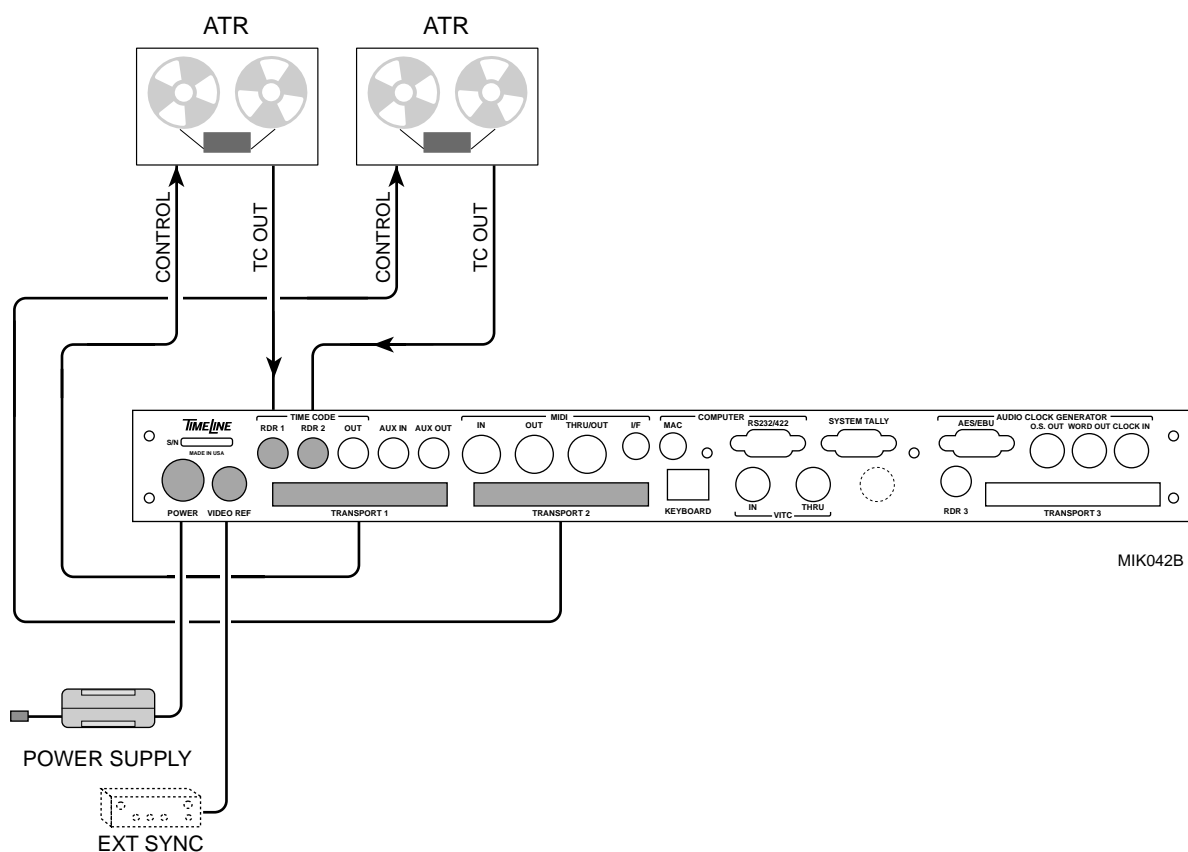

Figure Chapter 3 -2. Connect the Transports to the System Unit

Each transport must be directly connected to the Micro Lynx System Unit.

### Procedure

1. Connect each transport (40-pin transport cable) to the System Unit.
  - a. Connect the Transport 1 port to the remote or synchronizer port on the first machine.
  - b. Connect the Transport 2 port to the remote or synchronizer port on the second machine.
  - c. If the M3 card is installed, connect the Transport 3 port to the remote or synchronizer port on the third machine.
2. Connect the time code cables.
  - a. Connect the Transport 1 time code output cable to the System Unit time code RDR 1 input.
  - b. Connect the Transport 2 time code output cable to the System Unit time code RDR 2 input.

- c. If the M3 option card is installed, connect the Transport 3 time code output cable to the System Unit time code RDR 3 input.

**Note:** If the transport being controlled is a Sony RS422 machine control protocol, a separate LTC connection is not required. The Micro Lynx will use Serial Time Code on the RS422 connector to synchronize the machine.

- 3. For video or digital audio transports, connect the video sync reference.
  - a. Connect the System Unit Video Reference VID REF connector to the same video sync reference as the VTR/DTR.
  - b. If the TimeLine VSG option is installed, connect the System Unit Video Reference VID REF connector to the Video Sync input on the VTR/DTR machine.

**Note:** The Micro Lynx VID REF BNC connector is used for either input or output of video reference signals. If external video reference is selected, then the internal VSG card is inhibited. It is not possible to damage the VSG card by connecting an external video reference signal.

**Table Chapter 3 -2. Cable Check List**

Between Equipment	Connector	From / To
SU and Transports	40-pin	System Unit to each transport remote or synchronizer connector
SU and Transport time code inputs and outputs	1/4" stereo	System Unit RDR IN to the transports time code output connector
SU to EXT Video	BNC	System Unit to Video Reference Sync source or VTR/DTR Video Sync input if TimeLine VSG option installed

## Connect the Keyboard Controller Cables

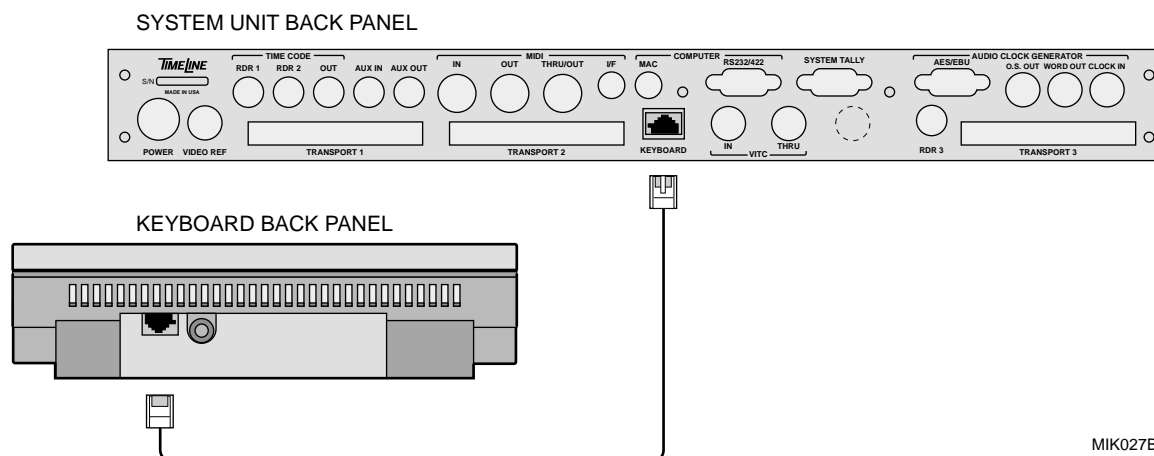

MIK027B

Figure Chapter 3 -3. Micro Lynx System Unit to Keyboard Controller Connection

### Procedure

1. Insert one end of the telephone style cable (8-pin RJ 45) into the KEYBOARD connector on the System Unit.
2. Route the cable to the Keyboard Controller.
3. Insert the other end of the cable into the SYSTEM jack on the Keyboard Controller.
4. Press the POWER switch on the System Unit front panel.
5. The POWER ON and SYSTEM VALID LEDs should light. After a few seconds, the KEYBOARD DATA and VALID LEDs should light and the Keyboard Controller will initialize.

## Connect the AUX Input

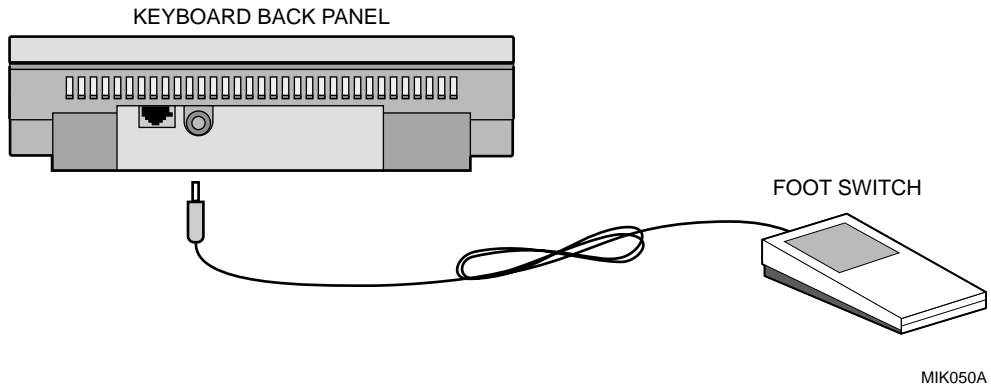

**Figure Chapter 3 -4. Micro Lynx Keyboard Controller to Foot Switch**

An AUX input socket is provided to connect a foot switch. It may be connected to any kind of switch with a toggle on and off function. The cable is not supplied with the Micro Lynx.

### Procedure

1. Insert one end of the 1/4" stereo jack into the AUX jack on the Keyboard Controller.
2. Use a three-pole jack plug wired so that the switch contacts between the tip and the ring.

---

### **Warning**

Do not use a mono jack plug connector.

---

3. The footswitch is programmed to punch the Micro Lynx in and out of record.

**Table Chapter 3 -3. AUX Connector Pin Description**

Pin	Description
Tip	Switch +
Ring	Switch -
Sleeve	Ground

## Quick Test and Initialization Procedure

This procedure tests the ability of the different pieces of equipment to communicate with each other and initializes the Micro Lynx. Upon completing these procedures, you will be ready to run the system.

### Procedure

#### *On the Tape Machine:*

1. [EXT]

Place a reel of time coded tape on the machine(s). Set the Tape Machine to external speed (some tape machines will automatically be set to external by the Micro Lynx).

#### *On the System Unit:*

2. [POWER]

*POWER LED turns on  
SYSTEM DATA LED on  
SYSTEM VALID LED on  
KEYBOARD SIGNAL LED on  
KEYBOARD VALID LED on*

Turning on the System Unit power also provides power to the Keyboard Controller. System internal communications are operational. Keyboard communications are operational.

#### *On the Keyboard Controller:*

3.

```
Lamp test, Holding memory
```

MOTION CONTROL LEDs are sequentially tested.

4.

```
Micro Lynx Keyboard Control Unit  
Version x.xxx
```

The software revision number is displayed.

5.

```
Tran: A AUTO Serial TRANSPORT  
Tran: B AUTO Serial TRANSPORT
```

Displays the transport types selected for each machine. If the incorrect transports are displayed, use steps 8-13 to select the correct transport.

```
Tran: C AUTO Serial TRANSPORT  
Ref: IntFix
```

M3 Card not installed. Displays currently selected system reference.

```
Hold the "GRP" key, and add  
groups in order of priority
```

Display message.

6.

*F1 LED on*  
*F2 LED on*  
*F3 LED on*  
*REF LOCK LED on*  
*GRP LED flashing*  
*A LED flashing*  
*B LED flashing*  
*TCG LED flashing*  
*MIDI LED flashing*

The Keyboard LEDs light. The 'C' LED will flash if the M3 card has been installed. When TCG is selected, MIDI is automatically selected.

7. [SETUP]

*SETUP LED flashing*  
*REF LOCK LED on*  
*SYS LED on*  
*LAST LED on*  
*NEXT LED on*  
*+ LED on*  
*- LED on*

You are now in setup mode. The LEDs that allow you to move through the menus turn on.

Setup: System options Selection: LED Brightness: 100%
--

Display Message

8. [TRAN]

*TRAN LED on*  
*A LED on*

The first transport A (Transport 1) must be identified by manufacturer and machine type.

Setup: AUTO Serial TRANSPORT Tran:
---------------------------------------

The default transport selection is displayed. You have entered the transport select mode.

9. [NEXT]

Setup: AMPEX ATR-100 Tran:
-------------------------------

Using the [NEXT] or [LAST] key select the manufacturer of the machine connected to the A (Transport 1) port. For this example select Ampex.

**Note:** The default transport selection “AUTO Serial TRANSPORT” will automatically detect the presence of most serial transports. Please refer to the Appendix for a complete listing of available transports.

10. [+]

```
Setup: AMPEX ATR-124
Tran:
```

Press [+] and [-] keys to select the machine type. Refer to the Cable Reference Guide, in the Appendix, for the machines supported.

11. [B]

```
Setup: NO TRANSPORT
Tran:
```

Select the second transport B (Transport 2), repeat steps 8-11 until all machines (A-C) have been set up.

12. [SETUP]

```
Hold the "GRP" key, and add
groups in order of priority
```

Machine selection is complete and the setup is saved.

13. [SOLO]

```
SOLO:a . a→ 0
0
```

Use the transport controls to check motion.

14. [>]

```
SOLO:a >L a-00:00:00:00
0
```

Puts the A machine into play, time code numbers will advance if time code has been striped onto the tape.

[<<]

```
SOLO:a << a-00:00:00:00
0
```

Puts the machine into rewind, time code should run backward.

[>>]

```
SOLO:a >> a-00:00:00:00
0
```

Puts the machine into fast forward, time code should run forward.

[ ] STOP

```
SOLO:a . a→ 1:01:14:07
0
```

Stops the A machine's transport and displays the final time code number received.

15. [B]

SOLO:b >L	a→ 2:09:10:07
	0

Solo the b machine. Use the transport controls to check motion.

[ ] STOP

SOLO:b .	a→ 2:09:10:03
	0

If the M3 card is installed, repeat step 14 and 15, but select machine C.

16. [GRP] + [A]  
[GRP] + [B]

A* b	A→00:00:00:00
. .	0

While holding the [GRP] key, press [A], release [A], continue to hold the [GRP] key, press [B] then release both keys.

17. [ALL STOP]  
[ ] STOP

A* b	A→00:00:00:00
. Ch	

Press [ALLSTOP] then [ ]. Assuming that both machines have the same time code then the b machine will chase A and park at the A time code, ready to synchronize.

18. [PLAY]

A* B	A→00:00:00:00 11
>L >L	

The A machine goes into play followed by the b machine. Both machines will lock up, a group lock to internal speed reference (II) will show in the display. The time to lock will be slightly longer the first time as the Micro Lynx learns the transports characteristics, subsequent lock times will improve noticeably.

**You are ready to use the Micro Lynx.**

## Quick Check Troubleshooting

**Table Chapter 3 -4. Troubleshooting the System Unit**

<i>Situation</i>	<i>Solution</i>	<i>Conditions</i>
POWER ON LED fails to turn on	Check all power supply connections. Check that the AC MAINS supply is OK.	
SYSTEM DATA & VALID LEDs fail to turn on	Hold [CLR] + [SYS] key on Keyboard to reset SU	SU failed to internally initialize correctly

**Table Chapter 3 -5. Troubleshooting the System Unit communications with the Keyboard Controller.**

<i>Situation</i>	<i>Solution</i>	<i>Conditions</i>
SU Keyboard DATA & VALID LEDs fail to turn on	Check the Keyboard to SU cable connection	Communications between the Keyboard and SU failed to initialize correctly
Keyboard display and LEDs fail to turn on	Check that the SU has correctly powered up Check the Keyboard to SU cable connection	
	Reset the Keyboard by holding [CLR] and pressing [SETUP]	Initiate a Keyboard memory clear and reset

**Table Chapter 3 -6. Troubleshooting the Micro Lynx communications with the machines.**

<i>Situation</i>	<i>Solution</i>	<i>Conditions</i>
Machine stays in stop or Micro Lynx does not read time code	Check that the transport control cable and time code RDR are connected to the correct transport and time code connectors	Incorrect or cross-wired cables
Machine behaves incorrectly or erratically	Check if correct transport interface cable installed Check if correct transport type is selected	
Machine does not respond	Check machine selected in group select (A-C)	
Machine not synchronizing	Check that the machine is selected for external control	



# Chapter 4 Getting Started

---

## Introduction

Once the Micro Lynx system is installed, turn it on. Use the basic operating procedures in this chapter to demonstrate the Micro Lynx system features and controls. This chapter will help you to quickly become familiar with Micro Lynx operation and capabilities.

Refer to the Keyboard Controller chapter for more detailed information about each of the keys.

## Turn On and Initialization

The Micro Lynx has a battery back-up memory system. Each time the system is turned on, it powers up in the same condition as when powered down. All of the setup and transport information previously entered is immediately available.

However, the first time the Micro Lynx is turned on, the transports being used must be selected. The Installation chapter provides instructions to select the transport types. For subsequent power-ons, the last transport setup will be displayed. Always verify that the transport is correctly selected. The following is an abbreviated turn on procedure.

### Procedure

#### ***On the Tape Machine:***

1. [EXT]

Place a reel of time coded tape on the machine(s). Set the Tape Machine to external speed (some tape machines will automatically be set to external by the Micro Lynx).

**On the System Unit:**

2. [POWER]

*POWER LED turns on  
SYSTEM DATA LED on  
SYSTEM VALID LED on  
KEYBOARD SIGNAL LED on  
KEYBOARD VALID LED on*

Turning on the System Unit power. System internal communications are operational. Keyboard communications are operational.

**On the Keyboard Controller:**

- 3.

```
Lamp test, Holding memory
```

MOTION CONTROL LEDs are sequentially tested.

```
Micro Lynx Keyboard Control Unit  
Version x.xxx
```

The software revision number is displayed.

```
Tran: A AUTO Serial TRANSPORT  
Tran: B AUTO Serial TRANSPORT
```

Displays the transport types selected for each machine. If the incorrect transports are displayed, use the initialization procedure in the Installation chapter to select the correct transport type. If this is the first time that the Micro Lynx has been turned on, or the Keyboard has been reset, transports are not yet assigned and No Transport is displayed.

```
Tran: C Not Available  
Ref: IntFix
```

Displays transport type selected if M3 option is installed; otherwise displays Not Available. Displays currently selected system reference.

```
Hold the "GRP" key, and add  
groups in order of priority
```

The Micro Lynx default is group mode. When no machines are selected to the group, a prompt telling you how to select machines to the group is displayed.

*F1 LED on  
F2 LED on  
F3 LED on  
REF LOCK LED on  
GRP LED flashing  
A LED flashing  
B LED flashing  
TCG LED flashing*

The Keyboard LEDs light. The C LED will flash if the M3 card has been installed. The F3 LED will come on if a VITC Reader Card has been installed.

**Selecting a transport (if selections have been made, jump to Step 9)**

4. [SETUP] + [TRAN] + [A]

SETUP LED flashes  
 TRAN LED on  
 A LED on

Select the setup mode. Each transport must be identified by manufacturer and machine type.

```
Setup: AUTO Serial TRANSPORT
Tran:
```

The default transport selection is displayed. You have entered the transport select mode.

5. [NEXT]

```
Setup: AMPEX ATR-100
Tran:
```

Using the [NEXT] or [LAST] key select the manufacturer of the machine connected to the A (Transport 1) port. For this example select Ampex.

6. [+]

```
Setup: AMPEX ATR-124
Tran:
```

Press [+] and [-] keys to select the machine type. Refer to the Cable Reference Guide, in the Appendix, for the machines supported.

7. [B]

```
Setup: AUTO Serial TRANSPORT
Tran:
```

Select the second transport B (Transport 2), repeat steps 4-6 until all machines (A-C) have been set up.

8. [SETUP]

```
Hold the "GRP" key, and add
groups in order of priority
```

Machine selection is complete and the setup is saved.

**Initialization Procedure:**

9. [SOLO]

```
SOLO:a . a-> 1:01:14:07
0
```

In Solo mode only one transport is controlled. Use the transport controls to check motion.

10. [>] PLAY

```
SOLO:a >L a-> 1:01:14:07
0
```

Put the machine into play, time code should be running.

[<<] RWD

```
SOLO:a <<                a→ 1:00:00:03
                             0
```

Puts the machine into rewind, time code should run backward.

[>>] FFD

```
SOLO:a >>                a→01:07:14:09
                             0
```

Puts the machine into fast forward, time code should run forward.

[ ] STOP

```
SOLO:a .                  a→ 1:01:14:07
                             0
```

Transport should stop.

11. [B]

```
SOLO:b .                  b→ 1:01:14:07
                             Err: 0.-
```

Solo the next machine. Use the transport controls to check motion. If the M3 card is installed, repeat steps 9 and 10, but select machine C.

[>] PLAY

```
SOLO:b >L                b→ 1:01:14:05
                             Err: 0
```

Puts the machine into play, time code should be running.

12. [ ] STOP

```
SOLO:b .                  b→ 2:09:10:03
                             Err: 0
```

***You are ready to use the Micro Lynx.***

## Set the System Reference

Before using the system, decide what system speed reference your machines will be locked to. When a system reference is selected, the Micro Lynx will synchronize all machines including the Master, as slaves to this timing reference. This provides fast and stable locking because each machine is independently controlled and locked.

The REF LOCK LED will light if the selected reference is valid. If the selected reference is not present or the Micro Lynx can not lock to it then the REF LOCK LED will flash.

The Micro Lynx time code generator is also locked to the system reference. This guarantees that when generating time code, the code rate (speed, not code type) is the same as that used by the rest of the system. There are six reference selections:

- I** Internal Fixed      Micro Lynx internal crystal
- i** Internal Variable    Micro Lynx internal frequency synthesizer
- L** External Video      An external composite or black burst video sync signal
- P** Aux Input            A pilot tone connected to the Aux input
- V** VSO Master         Variable speed, determined by vari-speeding the Master transport
- A** ACG                 The Micro Lynx Audio Clock Generator card

The Micro Lynx reference defaults to Internal Fixed (I). The system speed or rate defaults to 29.97 Frames and the generator time code type to 30 Frames (SMPTE 30 Frame). Unless you use a different frame rate, for example 25 Frame EBU, a video, or digital machine that should be referenced to video sync, then you should use this reference to get started. Use the following procedure to change the system reference.

System timing parameters are set in the TCG Options Menu, the following menu selections are available:

**Table Chapter 4 -1. TCG Options Menu**

KEY	MENU	SUB-MENU	RANGE
TCG	TCG Options	0 System Ref	<i>Intfix, Intvar, Extvid, Aux, VSO Master, ACG</i>
		1 System Spd/Code	<i>24Hz/24; 25Hz/25 (PAL); 29.97Hz/DF; 29.97Hz/30 (NTSC); 30Hz/DF; 30Hz/30</i>
		2 Varispeed %	<i>87.5% - 112.5% (100.00%) Jog/Shtl Wheel = ±0.1% +/- = ±0.1%</i>
		3 TCG Group Mode	<i>Play, Run; Play, Mute; Play, Wind</i>
		4 TCG Still Mode	<i>Off, On</i>
		5 Aux Output Sel	<i>Pilot, Reshape 1, Reshape 2, Reshape 3, GPI-2 Beep</i>
		6 Video Sync Gen	<i>Off, On</i>
* Factory default settings are in italics.			

### Procedure

```
SOLO:b . b→ 1:01:14:05  
Err: 0.-
```

- 1. [SETUP] + [TCG] + [0]

SETUP LED flashes  
TCG LED turns on

Enter Setup mode. Select the time code generator menu.

```
Setup: TCG options  
Selection: System Ref: IntFix
```

Select time code generator and system reference

- 2. [+]

```
Setup: TCG options  
Selection: System Ref: IntVar
```

Select the next reference option.

- 3. [-]

```
Setup: TCG options  
Selection: System Ref: IntFix
```

Select the previous reference option.

- 4. [NEXT] (or 1)

```
Setup: TCG options  
Selection: System Spd/Code: 29.97 Hz/30
```

The current generator rate and code type are displayed.

- 5. [+]

```
Setup: TCG options  
Selection: System Spd/Code: 30 Hz/DF
```

The next generator rate and code selection is displayed.

[+]

```
Setup: TCG options  
Selection: System Spd/Code: 30 Hz/30
```

The next generator rate and code selection is displayed.

[-]

```
Setup: TCG options  
Selection: System Spd/Code: 29.29 Hz/30
```

Go back and select the appropriate code speed.

- 6. [SETUP]

```
SOLO:b . b→ 1:01:14:05  
Err: 0.-
```

Exits setup mode and returns to the normal operating display.

## Generate Time Code

The Micro Lynx generates SMPTE and MIDI time code. Two macro keys have been programmed to automate the process of generating and striping time code.

Pressing [MACRO] then [9] (DUR) runs a macro, which makes the Micro Lynx ready to generate time code. All machines are deselected from the group, all transports are set to wild speed and the Micro Lynx is placed into TCG Setup mode.

Pressing [MACRO] then [8] (OUT) runs a macro, which exits the time code striping mode and returns the Micro Lynx machine to resolve mode.

## Procedure

1. [MACRO] + [9] (DUR)

Macro 9 automatically sets the Micro Lynx to generate time code. It ungroups any group, sets all transports to wild speed, and leaves the Micro Lynx in TCG setup mode.

*Note:* To select a reference speed other than the default, the group must be ungrouped or the reference must be the master.

2. TCG LED on

```

Setup:  TCG options
Selection:  System Spd/Code: 29.29 Hz/30

```

Use the [+] and [-] keys to select the system speed and code type to generate.

3. [SETUP]

SETUP LED off

The normal operating screen is visible.

- 4.

```

SOLO:t .                t-> 0:00:00:00
                        Err: 0.00

```

The current time code generator value is displayed.

5. [>] PLAY

```

SOLO:t >L              t-> 1:00:00:00
                        Err: 0.00

```

The generator runs locked to the system reference.

6. [ ] STOP

```

SOLO:t .                t-> 1:00:00:00
                        Err: 0.00

```

The generator stops running.

- 7. [MACRO] + [8] (OUT)

The transport(s) are returned to resolve mode and ready for normal operation.

**To start the generator at a specific time code value:**

- 8. [CLR] + 1 00 00 00

```
SOLO:t . t→ 1:03:45:19
1:00:00:00
```

One hour is entered into the Data Entry register.

- 9. [STO]

*STO LED flashes*

```
Store reg or mem t→ 1:03:45:19
1:00:00:00
```

The Micro Lynx is ready to store register or memory information.

- [0] (TIME)

```
SOLO:t . t→ 1:00:00:00
Time: 1:00:00:00
```

One hour is now stored in the Generator Time register.

- 10. [>] PLAY

```
SOLO:t >L t→ 1:00:00:00
Time: 1:00:00:00
```

The generator will generate time code starting at 1 hour locked to the system reference.

## Capture and Locate

The Micro Lynx can capture and store in memory up to 100 time code numbers. These can be retrieved and used as auto-locate positions or for other time code operations.

### Procedure

1. [A]

SOLO:A	A→ 1:03:52:17
	0

For this example we will Solo a machine. Capture and Locate can be done in both Solo and Group mode.

#### **Capture a value:**

2. [>] PLAY + [CAPT]

*CAPT LED flashes*  
*STO LED flashes*

Play to the time code that you want to capture and save. The Micro Lynx has captured a time code and is ready to store the number.

Store reg or mem	A→ 1:07:02:20
	1:03:52:17

3. [MEM]

*MEM LED flashes*

Store memory	1:03:52:17
--------------	------------

Choose a memory location to store the time code number.

4. [1]

SOLO:A >L	A→ 1:09:24:04
	Mem 1 1:03:52:17

5. [CLR]

SOLO:A >L	A→ 1:10:16:10
-----------	---------------

Clear the calculator data entry register.

#### **Retrieve a value stored in a memory location:**

6. [MEM]

*MEM LED flashes*

Recall memory	0
---------------	---

The Micro Lynx is ready to recall a time code number that is stored in a memory location.

7. [1]

```
SOLO:A >L                               A→ 1:11:07:12
                                           Mem 1  1:03:52:17
```

The value stored in memory 1 is retrieved.

**Locate using the value in the Data Entry register (lower right of display) as the locate point:**

8. [LOC]

```
SOLO:A >Loc                             A→ 1:03:47:17
                                           Mem 1  1:03:52:17
```

The transport will locate to 1:03:47:17, the time code number in the Data Entry register (memory location 1) minus the Preroll (5 seconds default).

## Make a Group

The Micro Lynx can simultaneously control up to three tape machines, the time code, and MIDI time code generator. When play on the Motion Control keys is pressed, all machines in the group will go into play and synchronize.

When the Micro Lynx first powers up, no machines are selected, so you must set up your machines. Use the GRP and Machine Select keys (A-C, TCG, and MIDI) to group machines. In group mode, the display shows the status of the Master machine; individual machine status can be viewed by pressing the specific machine key.

### Procedure

1. [GRP]

*GRP and machine LEDs flash*

```
Hold the "GRP" key, and add
groups in order of priority
```

This is the machine selection prompt. It is assumed that you have not grouped the machines yet.

2. [GRP] + [A]  
 [GRP] + [B]  
 [GRP] + [TCG]

*A LED turns on  
 B LED turns on  
 TCG LED turns on  
 MIDI LED turns on*

Press [GRP], hold it, and press the Machine Select key. The master machine is displayed as a capital letter and the slave machines as lower case letters. When TCG is included in the group, MIDI is also automatically grouped.

```
A* b t                               A→ 1:03:47:17
. . .                                 0
```

Time code and machine letters are displayed and the A machine is the Master.

3. [B]

```

STAT:b .                b→ 1:03:47:17
. . .                  Err:      0.-

```

Put the slave machine b into group status mode. In group status mode you may check the time code and error for that machine.

4. [B] or [GRP]

```

A* b t                  A→ 1:03:47:17
. . .                  0

```

Press the machine key [B] again or [GRP] to return to Group mode.

#### **Remove a machine from the Group:**

5. [GRP] + [B]

```

A* t                    A→ 1:03:47:17
. .                    0

```

Press [GRP] and the machine select key to remove a machine from the group. In this example b is removed.

6. [GRP] + [B]

```

A* b t                  A→ 1:03:47:17
. . .                  0

```

Put the slave machine b back into the group.

## Locking in a Group

Before being used in the system, each machine controller must individually resolve and lock its associated tape machine. This is accomplished by soloing each tape machine and then playing it until it locks to the system speed reference.

Look at the display. In addition to identifying the machine status as master or slave, and showing the time code, it indicates whether the machine and group are in lock. The letter defines the reference source. In this example II is used; however, any of the reference letters may be used.

### Procedure

```

A* b t                  A→ 1:09:22:23
. . .                  0

```

1. [SOLO] + [A]

```

SOLO:A* .              A→ 1:09:22:23
                    Err:      0.-

```

Solo the first machine. The \* indicates that it is the reference machine and the capital letter indicates that it is the master.

2. [>] PLAY

```
SOLO:A >L                A→ 1:10:00:00
                        Err: 0.00
```

Press [>] on the motion control keys. As the tape machine plays, it will automatically resolve and lock.

3. [ ] STOP

```
SOLO:A .                A→ 1:10:00:00
                        Err: 0.-
```

Press [ ] on the motion control keys once the machine has achieved lock.

4. [B]

```
SOLO:b .                b→ 1:30:00:00
                        0
```

Solo the next machine. The lower case letter indicates that this is a slave machine. Repeat steps 2 - 4 for each machine.

5. [GRP]

```
A* b t                A→ 1:10:00:00
. . .                0
```

Enter Group mode. If the group prompt message "Hold the "GRP" key and add groups in order of priority" is displayed, perform the procedure described in "Make a Group".

6. [ALL STOP]

[ ] STOP

```
A* b t                b→ 1:30:40:01
. Ch .
```

Press [ALL STOP] followed by [ ]. The Slave machines will chase to the correct location.

7. [>] PLAY

```
A* b t                b→ 1:30:40:01 II
>L >L >L                0
```

Press [>]. The Group will lock. Lock status is indicated by the II to the right of the time code.

## Set an Offset

Offsets are used if the time code on two or more tapes are not coincident. For example, if tape A starts at 00:00:00:00 and tape B starts at 02:00:00:00, then a record in point of 00:30:00:00 cannot be correct for both machines. Use the Micro Lynx to enter an offset to automatically compensate for the time code difference between tapes.

**The Micro Lynx always calculates a machine's offset from the reference machine.** The Micro Lynx indicates the reference machine with an \*, the master machine with a capital letter and

slave machines with lower case letters. In this example, the A transport is the reference and master machine.

A* b t	b→ 1:09:22:23
	Err: 0.-

To change the reference machine, clear the group (Press [GRP] + [SETUP]), hold down the [GRP] key and reselect the machines (the first machine selected is the reference machine). If required, the Master machine can be different from the reference machine. In this case, the Master machine can have an offset from the reference machine. (See Change the Master Machine).

The offset is the difference in the number of frames between the reference and slave or master tape at the point where they are to be synchronized. For example:

Slave time code – Reference time code = offset number of frames  
 02:00:00:00 – 01:00:00:00 = +1 hour offset

When a machine is offset, the machine letter is marked with a (+) to show that an offset is present

**Note:** Offsets cannot be set for the reference machine.

In the following example A is the master and reference and B is the slave machine. A, B and TCG are grouped.

## Procedure

A* b t	b→ 1:09:22:23
. . .	0

1. [SOLO] & [A]

SOLO LED on  
 A LED on

SOLO:A	A→ 1:09:32:03 I
	0

Solo the Master machine.

2. [>] PLAY

SOLO:A >	A→ 1:09:32:03 II
	0

The A machine goes into play.

3. [ ] STOP

SOLO:A .	A→ 2:00:00:00
	Err: 0.-

Locate the machine to a point and stop.

4. [B] & [>] PLAY

*SOLO LED on*  
*B LED on*

```
SOLO:b                               A→ 1:09:32:03 I
                                     0
```

Solo the Slave machine.

2. [>] PLAY

```
SOLO:b >                             A→ 1:09:32:03 II
                                     0
```

The b machine goes into play.

5. [ ] STOP

```
SOLO:b >                             b→ 2:03:52:03
                                     Err: 0.-
```

Locate the B machine to a point and stop.

6. [CAPT]

*CAPT LED flashes*  
*STO LED flashes*

The slave time code position is captured. Micro Lynx prompts for a register to store it in.

```
Store reg or mem                     b→ 2:03:52:03
                                     2:03:52:03
```

7. [OFST] (5)

```
SOLO:b.                               b→ 2:03:52:03
                                     Ofst: 3:52:03
```

Press Calculator key [5] (OFST). The slave offset is automatically calculated and stored.

8. [GRP]

*A LED on*  
*B LED on*  
*GRP LED on*  
*TCG LED on*  
*MIDI LED on*

```
A* b+ t                               A→ 2:00:00:00
. . .                                  0
```

Return to group mode. The B transport is marked with a "+" to show that an offset is present.

9. [>] PLAY

```
A* b+ t                               A→ 2:00:00:00 II
>L >L >L                              0
```

The machines go into play and lock with the offset.

## 10. [ ] STOP

A* b+ t	A→ 2:00:00:00
. . .	0

**Offset calculation using sync points:**

## 11. [SOLO], [A] &amp; [&gt;] PLAY

SOLO LED on  
A LED on

SOLO:A >L	A→ 1:00:00:00
	Err: 0.00

Solo the Master machine.

## 12. [CAPT] &amp; [REF] (3)

CAPT LED flashes  
STORE LED flashes

SOLO:A >L	A→ 1:00:00:00
	Ref: 1:00:00:00

## 13. [B]

B LED on  
SOLO LED on

SOLO:b >L	b→ 2:03:52:03
	Err: 1:00:00:00

Solo the Slave machine.

## 14. [CAPT] &amp; [SYNC] (4)

CAPT LED flashes  
STORE LED flashes

SOLO:b >L	b→ 2:03:52:03
	Sync: 2:03:52:03

Capture the sync point. The offset is automatically calculated and stored in the Offset register.

## 15. [RCL] &amp; [OFST] (5)

RCL LED flashing

SOLO:b >L	b→ 2:03:52:03
. .	Ofst: 1:03:52:03

Use the [RCL] key, if you wish to verify that the correct offset was stored in the Offset register.

## Trim an Offset

Sometimes an offset must be trimmed. The frame or subframe count can be increased or decreased in any register. The default trim values are 1 frame and 1 subframe. To change the trim increment value, refer to SYS under SETUP in the Keyboard Controller chapter.

**Trim Frame.** The value can be adjusted between 1 and 10 frames.

**Trim Subframe.** The value can be adjusted between 1 and 25 subframes.

### Procedure

1. [RCL] & [7] (OFST)

```
SOLO:A* b+ t          b→ 2:03:52:03
. . .                Ofst: 1:03:52:03
```

Assume that the A and B machines are grouped.

**Use + and – keys to trim:**

2. [B]

```
STAT:b .            b→ 2:03:52:03
. . .              Err: 0.-
```

Select status mode for machine B.

3. [TRIM]

*TRIM LED flashes*  
+ LED on  
– LED on

```
STAT:b .            b→ 2:03:52:03
Trim by 1          Ofst: 1:03:52:03
```

The frame trim increment is displayed. The offset register is automatically called.

4. [+]

Use the plus [+] key to dynamically increase the offset. Holding the [+] key down will make the key auto-repeat.

5. [-]

Use the minus [-] key to dynamically decrease the offset. Holding the [-] key down will make the key auto-repeat.

6. [TRIM]

```
STAT:b .            b→ 1:08:36:23
. . .              0
```

Press [TRIM] to exit trim mode, save the new offset and return to Status mode.

or [B]

```

A* b+ t           A→ 1:00:00:00
. . .             0

```

Press [B] to exit trim mode, save the new offset and return to Group mode.

or [CLR]

```

Old Offset used

```

Press [CLR] to exit trim mode without storing the new offset value.

#### **Use the Jog Wheel to trim:**

7. [TRIM]  
Jog Wheel  
*TRIM LED flashes*  
+ LED on  
- LED on

```

A* b+ t           A→ 1:04:12:23
. . .             0

```

The Jog Wheel can be used to dynamically trim the offset up or down instead of using the [+] and [-] keys.

**Note:** In this example, the tape machines were in Stop. An offset can be trimmed dynamically with the tape machines in play.

## Change the Master Machine

The Micro Lynx will allow any machine to be the group Master. You can change the Master at any time and all positional relationships will be maintained, any offsets will be transferred to the slave machines. Press and hold the new master machine key (A-C, TCG) followed by [SETUP].

### Procedure

#### **Change the Master Machine: (default operation)**

- 1.

```

A* b+ t           A→ 1:09:55:00
. . .             0

```

The normal group operating display.

2. [B] + [SETUP]

```

a+ B* t+         B→ 1:00:00:00
. . .             0

```

Press and hold [B], then press [SETUP], the Master and reference machine will be reselected. In this example, the B machine is selected as the new master.

**Note:** The original offset in B will transfer to the a and t machines as the system time code reference machine changes with the Master.

#### **Separate the Master and Reference Machines:**

**Note:** If Setup Group option, REF follow MSTR is set to OFF, then when the Master is changed, the reference machine will remain the same. See SETUP (in this section) and the Keyboard Control section for more information on this feature.

- [B] + [SETUP]

```
a* B+ t           B→ 1:00:00:00
. . .             0
```

Press and hold [B], then press [SETUP], the Master machine only will be reselected. In this example, the B machine is selected as the new master.

**Note:** The Master still has an offset from the time code reference machine.

**Change the Reference Machine:**

- [GRP] + [SETUP]

```
Hold the "GRP" key, and add
groups in the order of priority
```

Clear all machines from the group.

- [GRP] + [B]  
[GRP] + [A]  
[GRP] + [TCG]

```
a B* t           B→ 1:00:00:00
. . .             0
```

The first machine selected to the group becomes the Reference and Master.

- Repeat steps 4 and 5, but press [GRP] + [A] first to set the Micro Lynx back to A as Master and Reference, before proceeding to the next example.

## Do an Edit

The Micro Lynx has comprehensive Rehearse, Record, and Replay edit routines. In Points and Out Points can be quickly marked. The Micro Lynx cues all transports to the preroll point, executes an automatic record at the in point, and drops out of record at the out point.

F1 is a macro that sets the In Point.

F2 is a macro that sets the Out Point.

### Procedure

- [>] PLAY

```
A* B. t           A→ 1:00:00:00 II
>L >L >L         0
```

The group goes into play and locks.

## 2. [F1]

```
A* B. t           A→ 1:00:00:00 II
>L >L >L           (A) In: 1:00:00:00
```

Mark a record in point. The message MACRO I EXECUTING will be momentarily displayed.

## 3. [F2]

```
A* B. t           A→ 1:00:20:00 II
>L >L >L           (A)Out: 1:00:20:00
```

Mark a record out point. The message MACRO II EXECUTING will be momentarily displayed.

## 4. [EDIT]

*EDIT LED on*  
*CUE LED flashes*  
*REPLAY LED flashes*  
*REC LED flashes*  
*REH LED flashes*

```
Select edit mode   A→ 1:00:00:00
. . .              (A)Out: 1:00:20:00
```

Enter Edit mode. Edit mode selection LEDs flash to prompt a selection.

## 5. [REC]

*EDIT LED on*  
*CUE LED on*  
*REC LED flashes*

```
55:00:00           A→ 55:00:00
CueCue             (A)Out: 1:00:20:00
```

Select Edit Record mode. Group cues to the cue point. The preroll time defaults to 5 seconds. (Cue point = IN - PREROLL)

## 6.

```
"WARNING: No Active Transports Enabled"
```

The group goes into play and locks. A prompt describing the machine record status is displayed. Hold the [RDY] key and press machine keys (A-C) as required to record enable each machine.

```
In: 5:00           A→ 55:00:00
Dur: 20.00         (A)Out: 1:00:20:00
```

Preroll time counts down.

```
Record            A→ 1:00:00:00 LL
Dur: 20.00        (A)Out:
```

The Group goes into record at the in point.

```
DONE              A→ 1:20:00:00 LL
Post: 5.00        (A)Out:
```

The Group drops out of record at the out point and post rolls. The Post roll time defaults to 5 seconds.

7. [EDIT]

*EDIT LED on*  
*CUE LED flashes*  
*REPLAY LED flashes*  
*REC LED flashes*  
*REH LED flashes*

Select edit mode	A→ 1:00:00:00
. . .	(A)Out: 1:00:20:00

Enter Edit mode. Edit mode selection LEDs flash to prompt a selection.

8. [REPLAY]

*EDIT LED on*  
*CUE LED on*  
*REPLAY LED flashes*

"WARNING: No Active Transports Enabled."
--

The group goes into play and locks. A message describing the machine record status is displayed.

In: 5:00	A→ 55:00:00
Dur: 20.00	(A)Out:

Preroll time counts down.

REPLAY	A→ 1:00:00:00 LL
Dur: 20.00	(A)Out:

The Group goes into replay at the in point.

DONE	A→ 1:20:00:00 LL
Dur: 5:00	(A)Out:

The Group drops out of replay at the out point and post rolls. The Post roll time defaults to 5 seconds.

9. [LOOP]

Cue: 55:00:00	A→ 55:00:00
CueCue .	(A)Out: 0

If [LOOP] is selected before the edit is complete, then the group will recue to the preroll point and repeat the sequence.

## Reset the System

If it becomes necessary to clear or reset the system, the calculator [CLR] key is used in combination with a number of other keys. You can reset the system or a specific parameter value to its default. In the following section, hold down the first key, then press the second key. Before these commands are executed, a warning message is displayed.

Press ENTR to confirm

### CLR

In normal operating mode this key clears the calculator data entry register. In setup mode it quickly resets track record enables to off and variable rates back to nominal values. For example, press [SETUP] then [TCG]. Press [CLR] to set the varispeed percentage back to 100%.

### CLR + SYS

Simultaneously pressing these keys will cold boot or reset the System Unit. This clears all user setup options back to the defaults.

If you are sure that you want to reset the System Unit, press the [ENTR] (SHTL) key.

### CLR + SETUP

Simultaneously pressing these keys will reset the Keyboard Controller. This key combination is used to initiate either a “cold” or “warm” reset of the keyboard after which the unit returns to normal operating mode.

If you are sure that you want to reset the Keyboard Controller, press the [ENTR] (SHTL) key. This initiates a “Warm boot” or a soft reset in the Keyboard Controller. All local keyboard variables are re-initialized, no information is lost, and the Keyboard Controller returns to normal operation.

To completely reset or “cold boot” the keyboard, press [CLR] + [SETUP] followed by the [ENTR] key.

Press [ENTR], then press and hold the [CLR] key. Any information that is stored in the System Unit will be restored. However, any data that is stored in the Keyboard Controller will be erased. See the Keyboard Controller chapter for a more detailed explanation.



[ENTR] (SHTL)

"Holding Memory" unless you press and hold CLR key within 1 second

Lamp test, Holding memory

5. [CLR]

Lamp test, Clearing memory

#### CLR + TRAN

6. [SOLO] & [A]

SOLO:A > A→ 1:00:00:00  
0

Select Solo mode. Select the machine to reset.

7. [CLR] + [TRAN]

Transport Clearing Now

The selected machine is reset to factory default parameters.

**Remember:** It is not necessary to reselect the transport.

## Customize the Micro Lynx Setup

The Micro Lynx has a comprehensive setup procedure that allows the system to be customized precisely for a particular mode, transport or application. The setup options are organized by function in a menu type format in which there are currently 14 option categories:

Key	Category
ACG	Audio Clock Generator
SYS	System
TRAN	Transport
EVNT	Events
MEM	Memory
TCG	Time Code Generator & System Reference
GRP	Group
LOOP	Loop
RDY	Record Ready
TRKS	Tracks
KEY	Rollback, REH, REC Operation
EDIT	Edit
MACRO	Program Macro
F3	VITC Reader

Press the [SETUP] key to enter setup mode. Next, select the category that you wish to modify. After modifying the selected

option, exit setup mode by pressing [SETUP] a second time. Each menu in a particular category can be accessed either directly by selecting it numerically or sequentially by pressing the [LAST] and [NEXT] keys. Step through the menu options by pressing the [+] and [-] keys. The setup key options are provided in a table at the end of this chapter and in Appendix A. All selections and associated numbers are listed.

If power to the Micro Lynx is turned off, ALL settings are saved. The last settings entered will be restored when the Micro Lynx is turned back on. The following is a typical Micro Lynx Setup Menu:

Table Chapter 4 -2. Micro Lynx Setup Menu

KEY	MENU	SUB-MENU	RANGE
SYS	System Options	0 LED Brightness	20% - 100% (100%)
		1 DSPL Contrast	30% - 100% (70%)
		2 DSPL Timeout	Off, 1, 5, 10, 20 min., Never
		3 Jog Speed	1-10 (5)
		4 Trim Frame	01-10 (01)
		5 Trim Subframe	01-25 (01)
		6 Port Select	MAC:MIDI, 422:ES MAC:ES, 422:Off

## Setup

Table 4-3 is a complete list of all of the Micro Lynx setup options. The table is in quick reference form that excludes any detailed explanations of each option. For a more comprehensive explanation of each of the menus, see the Keyboard Controller chapter.

Press the [SETUP] key to enter setup mode. Next press the key for the category that you wish to modify. After modifying the selected option, exit setup mode by pressing [SETUP] a second time. Each menu in a particular category can be accessed either directly by selecting it numerically or sequentially by pressing the [LAST] and [NEXT] keys. The individual menu options are stepped through by pressing the [+] and [-] keys.

Table Chapter 4 -3. Micro Lynx Setup Selections

<p><b>[SETUP]</b></p> <p><b>[ACG] ACG OPTION</b></p> <ul style="list-style-type: none"> <li>[0] NOM S/RATE OUT             <ul style="list-style-type: none"> <li>32.000 Ks/s</li> <li>[+/-] 44.056 Ks/s</li> <li>44.100 Ks/s</li> <li>47.952 Ks/s</li> <li>48.000 Ks/s</li> </ul> </li> <li>[1] VAR RATIO OUT             <ul style="list-style-type: none"> <li>OFF</li> <li>ON</li> </ul> </li> <li>[2] VAR RATIO OUT %             <ul style="list-style-type: none"> <li>85%-115% (100.00%)</li> </ul> </li> <li>[3] OVERSAMPLE OUT             <ul style="list-style-type: none"> <li>128</li> <li>[+/-] 192</li> <li>256</li> <li>384</li> </ul> </li> <li>[LAST/NEXT] [4] NOM S/RATE IN             <ul style="list-style-type: none"> <li>32.000 Ks/s</li> <li>[+/-] 44.056 Ks/s</li> <li>44.100 Ks/s</li> <li>47.952 Ks/s</li> <li>48.000 Ks/s</li> </ul> </li> <li>[5] VAR RATIO IN             <ul style="list-style-type: none"> <li>OFF</li> <li>ON</li> </ul> </li> <li>[6] VAR RATIO IN %             <ul style="list-style-type: none"> <li>87.5%-112.5% (100.00%)</li> </ul> </li> <li>[7] OVERSAMPLE IN             <ul style="list-style-type: none"> <li>128</li> <li>[+/-] 192</li> <li>256</li> <li>384</li> <li>OFF</li> </ul> </li> <li>[8] REFERENCE IN             <ul style="list-style-type: none"> <li>AES/EBU</li> <li>CLOCK IN BNC</li> </ul> </li> <li>[EDIT] EDIT OPTION             <ul style="list-style-type: none"> <li>[0] EDIT Q/C             <ul style="list-style-type: none"> <li>DISABLE</li> <li>RETRY</li> <li>STOP</li> </ul> </li> <li>[1] EDITS ROLL AS             <ul style="list-style-type: none"> <li>MAST/SLAVE</li> <li>ALL SLAVES</li> </ul> </li> </ul> </li> <li>[EVENT] SELECT GPI OPTIONS <sup>1</sup> <ul style="list-style-type: none"> <li>[1] GPI 1             <ul style="list-style-type: none"> <li>NORMAL</li> <li>AUTOSET</li> <li>REC TALLY</li> <li>EDIT REC</li> <li>REH TALLY</li> <li>EDIT REH</li> <li>LOCK TALLY</li> </ul> </li> <li>[2] GPI 2             <ul style="list-style-type: none"> <li>[0] MODE             <ul style="list-style-type: none"> <li>NORMAL</li> <li>AUTOSET</li> <li>REC TALLY</li> <li>EDIT REC</li> <li>REH TALLY</li> <li>EDIT REH</li> <li>LOCK TALLY</li> </ul> </li> <li>[1] BEEP MODE             <ul style="list-style-type: none"> <li>OFF</li> <li>ON</li> </ul> </li> <li>[2] BEEP SPACING             <ul style="list-style-type: none"> <li>10-30 (20)</li> </ul> </li> <li>[3] LAST BEEP             <ul style="list-style-type: none"> <li>MUTED</li> <li>ON</li> </ul> </li> </ul> </li> </ul> </li> </ul>	<p><b>[GRP] GROUP OPTIONS</b></p> <ul style="list-style-type: none"> <li>[0] SEARCH MODE             <ul style="list-style-type: none"> <li>CHASE</li> <li>GROUP</li> </ul> </li> <li>[1] REF FOLLOW MSTR             <ul style="list-style-type: none"> <li>OFF</li> <li>ON</li> </ul> </li> <li>[2] GROUP PARKAHEAD             <ul style="list-style-type: none"> <li>0-30 (25)</li> </ul> </li> <li>[3] GRP LED STATUS             <ul style="list-style-type: none"> <li>NORMAL</li> <li>TIMECODE</li> </ul> </li> <li>[LOOP] LOOP OPTIONS             <ul style="list-style-type: none"> <li>[0] AFTER EDIT             <ul style="list-style-type: none"> <li>RE-EDIT</li> <li>REPLAY</li> </ul> </li> <li>[1] AFTER REPLAY             <ul style="list-style-type: none"> <li>END</li> <li>REPEAT</li> </ul> </li> <li>[2] AFTER END             <ul style="list-style-type: none"> <li>STOP</li> <li>RECUE</li> </ul> </li> </ul> </li> <li>[MACRO] PROGRAM MACRO             <ul style="list-style-type: none"> <li>[0-9] (1,2,3,8 &amp; 9)</li> </ul> </li> <li>[MEM] MEMORY OPTION             <ul style="list-style-type: none"> <li>MEMORY SIZE             <ul style="list-style-type: none"> <li>0-9</li> <li>00-99</li> </ul> </li> </ul> </li> <li>[MIDI] MIDI OPTIONS             <ul style="list-style-type: none"> <li>[0] MIDI OUT JACK             <ul style="list-style-type: none"> <li>OFF</li> <li>MTC</li> <li>MIDI DATA</li> <li>MTC + DATA</li> <li>I/F THRU</li> </ul> </li> <li>[1] I/F OUT JACK             <ul style="list-style-type: none"> <li>OFF</li> <li>MTC</li> <li>MIDI DATA</li> <li>MTC + DATA</li> <li>MIDI THRU</li> </ul> </li> <li>[2] MAC OUT JACK             <ul style="list-style-type: none"> <li>OFF</li> <li>MTC</li> <li>MIDI DATA</li> <li>MTC + DATA</li> <li>MAC JACK</li> </ul> </li> <li>[3] MIDI THRU JACK             <ul style="list-style-type: none"> <li>MIDI IN</li> <li>MIDI OUT</li> </ul> </li> <li>[4] MTC SOURCE             <ul style="list-style-type: none"> <li>MIDI IN JACK</li> <li>I/F JACK</li> <li>MAC JACK</li> </ul> </li> <li>[5] MIDI DATA SRC             <ul style="list-style-type: none"> <li>MIDI IN JACK</li> <li>I/F JACK</li> <li>MAC JACK</li> </ul> </li> <li>[6] MIDI RESOLVE             <ul style="list-style-type: none"> <li>OFF</li> <li>ACG SERVO</li> </ul> </li> </ul> </li> <li>[RDY] RECORD OPTIONS <sup>2</sup> <ul style="list-style-type: none"> <li>[0] REC ADV 30-IN             <ul style="list-style-type: none"> <li>0-255</li> </ul> </li> <li>[1] REC ADV 30-OUT             <ul style="list-style-type: none"> <li>0-255</li> </ul> </li> <li>[2] REC ADV 15-IN             <ul style="list-style-type: none"> <li>0-255</li> </ul> </li> <li>[3] REC ADV 15-OUT             <ul style="list-style-type: none"> <li>0-255</li> </ul> </li> <li>[4] REC ADV 7.5-IN             <ul style="list-style-type: none"> <li>0-255</li> </ul> </li> <li>[5] REC ADV 7.5-OUT             <ul style="list-style-type: none"> <li>0-255</li> </ul> </li> </ul> </li> </ul>	<p><b>[ROLLBACK, REH, REC] KEY OPTIONS <sup>3</sup></b></p> <ul style="list-style-type: none"> <li>[ROLLBACK] OR [0] ROLLBACK KEY             <ul style="list-style-type: none"> <li>[+/-] ROLLBACK</li> <li>PLAY-REV</li> </ul> </li> <li>[REH] OR [1] REHEARSE BY             <ul style="list-style-type: none"> <li>[+/-] PLAY+REH</li> <li>REH ONLY</li> </ul> </li> <li>[REC] OR [2] RECORD BY             <ul style="list-style-type: none"> <li>[+/-] PLAY+REC</li> <li>REC ONLY</li> </ul> </li> <li>[SYS] SYSTEM OPTIONS             <ul style="list-style-type: none"> <li>[0] LED BRIGHTNESS             <ul style="list-style-type: none"> <li>20%-100% (100%)</li> </ul> </li> <li>[1] DSPL CONTRAST             <ul style="list-style-type: none"> <li>30%-100% (70%)</li> </ul> </li> <li>[2] DSPL TIMEOUT             <ul style="list-style-type: none"> <li>OFF</li> <li>1 MIN</li> <li>5 MIN</li> <li>10 MIN</li> <li>20 MIN</li> <li>NEVER</li> </ul> </li> <li>[3] JOG SPEED             <ul style="list-style-type: none"> <li>1-10 (5)</li> </ul> </li> <li>[4] TRIM FRAME             <ul style="list-style-type: none"> <li>01-10 (01)</li> </ul> </li> <li>[5] TRIM SUBFRAME             <ul style="list-style-type: none"> <li>01-25 (01)</li> </ul> </li> <li>[6] PORT SELECT             <ul style="list-style-type: none"> <li>MAC: MIDI, 422:ES</li> <li>MAC: ES, 422:OFF</li> </ul> </li> <li>[TCG] TCG OPTIONS             <ul style="list-style-type: none"> <li>[0] SYSTEM REF             <ul style="list-style-type: none"> <li>INTFIX</li> <li>INTVAR</li> <li>EXTVID</li> <li>AUX</li> <li>VSO MASTER</li> <li>ACG</li> </ul> </li> <li>[1] SYSTEM SPD/CODE             <ul style="list-style-type: none"> <li>24 Hz/24</li> <li>25Hz/25 (PAL)</li> <li>29.97Hz/DF</li> <li>29.97Hz/30 (NTSC)</li> <li>30Hz/DF</li> <li>30Hz/30</li> </ul> </li> <li>[2] VARISPEED %             <ul style="list-style-type: none"> <li>87.5%-112.5% (100.00%)</li> <li>JOG/SHTL WHEEL = ±0.1%</li> <li>[+/-] = ±0.01%</li> </ul> </li> <li>[3] TCG GROUP MODE             <ul style="list-style-type: none"> <li>PLAY, RUN</li> <li>PLAY, MUTE</li> <li>PLAY, WIND</li> </ul> </li> <li>[4] TCG STILL MODE             <ul style="list-style-type: none"> <li>OFF</li> <li>ON</li> </ul> </li> <li>[5] AUX OUTPUT SEL             <ul style="list-style-type: none"> <li>PILOT</li> <li>RESHAPE 1</li> <li>RESHAPE 2</li> <li>RESHAPE 3</li> <li>GPI-2 BEEP</li> </ul> </li> <li>[6] VIDEO SYNC GEN             <ul style="list-style-type: none"> <li>OFF</li> <li>ON</li> </ul> </li> </ul> </li> </ul> </li></ul>	<p><b>[TRKS] TRACK OPTIONS</b></p> <ul style="list-style-type: none"> <li>[0] VIDEO TRACKS             <ul style="list-style-type: none"> <li>[+/-] SAFE</li> <li>READY</li> </ul> </li> <li>[1] VIDEO AUTO-RST             <ul style="list-style-type: none"> <li>OFF</li> <li>ON</li> </ul> </li> <li>[TRAN] MACHINE SELECT             <ul style="list-style-type: none"> <li>[LAST/NEXT] TRANSPORT MFGR</li> <li>[+/-] MACHINE MODEL</li> <li>[TRAN] TRAN OPTIONS <sup>2</sup> <ul style="list-style-type: none"> <li>[0] CAPSTAN MODE             <ul style="list-style-type: none"> <li>WILD</li> <li>RESOLVED</li> </ul> </li> <li>[1] CAPST SPD TRIM             <ul style="list-style-type: none"> <li>-128 TO +127 (0)</li> </ul> </li> <li>[2] LIFTER DEFEAT             <ul style="list-style-type: none"> <li>NEVER</li> <li>NORMAL</li> <li>NOT STP/PLAY</li> <li>ALWAYS</li> </ul> </li> <li>[3] RECORD IN             <ul style="list-style-type: none"> <li>PULSE REC</li> <li>P-REC,PLAY</li> </ul> </li> <li>[4] RECORD OUT             <ul style="list-style-type: none"> <li>PULSE PLAY</li> <li>P-REC, PLAY</li> <li>PULSE STOP</li> <li>P-REC,STOP</li> <li>P-PLAY,STOP</li> <li>PULSE OPTO</li> <li>SPECIAL OPTO</li> </ul> </li> <li>[5] REHEARSE IN             <ul style="list-style-type: none"> <li>LATCH REH</li> <li>PULSE REH</li> <li>P-REH,PLAY</li> <li>P-REH,RECLOG</li> <li>L-REH,RECLOG</li> <li>PULSE REC</li> </ul> </li> <li>[6] REHEARSE OUT             <ul style="list-style-type: none"> <li>UNLATCH REH</li> <li>PULSE REH</li> <li>SAVE AS REC</li> </ul> </li> <li>[7] APPROACH SPEED             <ul style="list-style-type: none"> <li>20-254</li> </ul> </li> <li>[8] BANDWIDTH LIMIT             <ul style="list-style-type: none"> <li>OFF</li> <li>ON</li> </ul> </li> <li>[9] READER MODE             <ul style="list-style-type: none"> <li>LTC/SER TC</li> <li>LTC/TT1</li> <li>SERIAL TC</li> <li>T.TIMER 1</li> </ul> </li> <li>[00] MUTE CONTROL             <ul style="list-style-type: none"> <li>NORMAL</li> <li>UNTIL RSLVED</li> <li>UNTIL LOCKED</li> <li>NOT LOCKED</li> </ul> </li> <li>[NEXT] LOCK THRESHOLD             <ul style="list-style-type: none"> <li>0-50 (35)</li> </ul> </li> <li>[NEXT] LOCK DELAY             <ul style="list-style-type: none"> <li>0-50 (10)</li> </ul> </li> <li>[NEXT] PARK WINDOW             <ul style="list-style-type: none"> <li>0-10 (10)</li> </ul> </li> </ul> </li> </ul> </li> </ul>
---	--	---	--

NOTE:  
 ALL KEYS ARE IN BRACKETS [ ].  
 FACTORY DEFAULTS ARE ITALICIZED.  
 1 PRESS EVENT KEY THEN DESIRED GPI NUMBER.  
 2 SELECT RDY OR TRAN, THEN MACHINE (A, B, OR C) TO SETUP OPTIONS.  
 3 USE KEYS 0, 1, 2 ONLY AFTER FIRST SELECTION.



# Chapter 5 Troubleshooting

---

## Introduction

The Micro Lynx provides several levels of user information: system error messages, prompts, messages and warnings.

**System error messages** are displayed when the Micro Lynx is unable to perform due to a system failure or communications discontinuity.

**Messages** are displayed if a command sequence is entered incorrectly or a precondition is required for a command to operate.

**Warnings** are displayed if an illegal combination of commands is entered, access is attempted to a device that doesn't exist or a condition exists that the operator may need to be aware of.

**Prompts** are displayed as a reminder when a specific keyboard entry sequence is required.

## System Error Messages

System error messages are not automatically displayed. When an error occurs, normal operation can continue provided that communications between each piece of the system have not been completely dropped. The [SYS] key will flash to indicate that a system error has occurred.

The Micro Lynx can generate and save multiple error messages. Each time an error condition occurs, such as losing communications between the Micro Lynx Keyboard Controller (KBD) and System Unit (SU), an error message is added to the stack. The error message stack is a list of errors created by the Micro Lynx program, which can be read at any time.

**Procedure**

1. SYS LED flashing

When the SYS LED flashes, a system error has occurred.

2. [SYS]

*Comm error*

The first error message in the error stack or list is displayed. Note down the message as you will be asked for this information by the factory should you be unable to correct the problem. Communications error is used in this example.

3. [SYS]

*Next error or  
Normal display*

Press [SYS] again to see the next error message and to exit when the list is done. The Micro Lynx holds error messages in a stack, when the top message is removed the next one is displayed. Repeat step 3 until all messages have been read.

4. [CLR]

*Display clears*

Press the [CLR] key to exit SYS ERROR mode and return to a normal operating display without clearing the list.

**ACG input lost lock** *Cause:* The ACG Option card has not locked to the incoming AES/EBU, Word or Oversample Clock because the signal is either not present or out of range.

*Solution:* Verify that the external digital audio clock is present and connected to the correct input. Check that the ACG setup parameters have been correctly configured.

**ACG output lost lock** *Cause:* The ACG Option card has not locked to the system reference.

*Solution:* Verify that the selected system reference is present. Check that the Keyboard Ref Lock LED is on.

**Communications error** *Cause:* The connection between the System Unit (SU) and the Keyboard Controller (KBD) has been dropped either momentarily or completely. Each time there is a communication error this message will be added to the stack.

*Solution:* Check the SU to KBD cable connection, reset either the SU or the KBD.

**Reference Not Present** *Cause:* A reference source, that is not present, has been selected.

*Solution:* Verify that the reference source is connected or that the correct reference source has been selected.

**Reference Src Changed** *Cause:* The reference source has been changed at some point

during operations. This may have occurred inadvertently.

*Solution:* Verify that the correct reference source is selected by checking TCG Option menu, in Setup mode.

**System Err XXXX** *Cause:* An internal communications inconsistency has occurred. The error type XXXX is a Hex number that will assist the factory in locating the problem. System error codes are specific to different parts of the Micro Lynx system. The first two characters define where the error was produced. The second two characters are the type of error.

For example: 00XX is System  
 88XX is ACG card  
 A0XX is machine A  
 A2XX is machine B  
 A4XX is machine C  
 E0XX is VITC

*Solution:* Note the system error number and contact the factory for further information.

**System Fps Changed** *Cause:* The system frame rate has been changed at some point during operations. This has probably been caused by a change in the reference machine time code type.

*Solution:* Verify that the correct time code is present on the tapes. Check that the correct frame rate and code type are selected, by checking TCG Option menu, in Setup mode.

**Tran:X Ampex Serial Checksum Error** *Cause:* A serial communications error has occurred with the specified Ampex transport.

**Tran:X Serial NAK Error** *Cause:* The specified serially controlled transport has responded with a negative acknowledge (NAK) to a Micro Lynx command.

*Solution:* Verify that the correct transport type has been selected in the Tran Setup menu.

**Tran:X Sony Serial Checksum Error** *Cause:* A serial communications error has occurred with the specified Sony transport.

## Self Test Messages

The Micro Lynx Keyboard has a Self Test procedure, that is invoked by pressing [GRP] + [SYS] and then confirming the key selection. The following messages and information is displayed during the self test process.

- Running Self Test** *Cause:* The keyboard self test procedure has been initiated.
- Checking Ram: 8K** *Cause:* The keyboard RAM is being checked.
- Checking Rom: 64K** *Cause:* The keyboard ROM is being checked.
- Checksum** *Cause:* The keyboard PROM is read and the checksum displayed. Press any key to continue self test.
- Dspl Contrast** *Cause:* The display contrast is ramped from 30% to 100%.
- Verify Lights** *Cause:* All keyboard LED's are lit for verification. Press any key to continue self test.
- LED Brightness** *Cause:* The keyboard LED's are ramped from 20% to 100% to check brightness matching.
- No keys pressed** *Cause:* The keyboard key test routine is entered. Press keys to confirm that they are being correctly scanned, the associated LED will also be tested. Press [SETUP] + [CLR] to exit the key test routine.
- Annn Bnnn Xnnn** *Cause:* The Jog/Shuttle test routine is entered, turn the wheel to check that the encoder values change. Press [CLR] to exit self test.

When Self Test is complete the Micro Lynx Keyboard will cold boot and return to normal operation.

---

## Error Messages

**Can't do this** *Cause:* You can't capture to the pre, post, or duration register.

*Solution:* Repeat the capture sequence and select a different register or memory.

**Must be slave** *Cause:* An operation has been selected that is only relevant to a slave transport. There are several operations that can only be performed on slave machines, not the reference or master machine. For example, setting an offset or a source sync point is done on a slave machine.

*Solution:* Select a slave machine.

**Tran:X Capstan Error** *Cause:* The capstan of the specified transport is not responding to synchronization control.

*Solution:* Make sure that the transport is set for external control.

**Tran:X No serial communications** *Cause:* The specified transport is not responding to serial control.

*Solution:* Make sure that the cable is properly connected to the transport. Check that the correct transport type has been selected in the transport setup menu.

**Tran:X Tape Out** *Cause:* The specified transport is not responding to a Micro Lynx motion command. The most common cause of this message is that the tape has spooled off the machine.

*Solution:* Check that there is a tape threaded on the machine.

**Tran:X Transport in Local** *Cause:* The specified serially controlled transport is switched to local.

*Solution:* Check that the Remote switch is set to remote at the machine.

## Warnings

- All groups not locked, Edit aborted** *Cause:* All machines within a group have not locked before the In Point in an Edit sequence. The system will retry the Edit unless Edit Q/C has been set to Stop in the Edit Options menu.
- Solution:* Establish which transport is not locking and rectify the problem. Lengthen the preroll, or if it is the master machine try operating in Group, Master/ Slave mode.
- All groups not locked, Q/C off** *Cause:* All machines within a group have not locked before the In Point in an Edit sequence. The system will continue to roll the edit as Edit Q/C has been disabled in the Edit Options menu.
- Solution:* Establish which transport is not locking and rectify the problem.
- Cue point after normal preroll, ignored** *Cause:* An Edit command has been issued and the Cue Point is after the In Point minus the system preroll.
- Solution:* Clear or set a new Cue Point.
- Edit ended early** *Cause:* An Edit sequence ended before the machines had reached the Out Point. This normally is the result of pressing stop or play.
- Holding memory unless you press and hold [CLR] key within 1 second** *Cause:* The Keyboard Controller has been reset by pressing [CLR] + [SETUP] and confirmed. If you press [CLR] the memory and register contents will be reset to the factory defaults. If not the current register and memory values will be retained.
- Lamp test, Clearing memory** *Cause:* A keyboard cold boot operation is in process. The keyboard will reinitialize to default parameters. Some information will be cleared.
- Lamp test, Holding memory** *Cause:* A keyboard warm boot operation is in process. The keyboard variables will re-initialize. No information is cleared.
- No in-point or cue-point set** *Cause:* A CUE command to locate the transports to the Cue Point has been issued and no Cue or In Point is set.
- Solution:* Set a Cue or In Point by using the [F3] or [F1] keys. Time code values can also be entered and stored to these registers by using [STO] and [CUE] or [STO] and [IN].
- Not Available** *Cause:* A transport or device has been selected that is not available.
- Solution:* Select a different transport.

- Old offset used** *Cause:* When trimming an offset, the trim process was exited by pressing [CLR].
- Solution:* This message informs you that the new offset was not saved and the old offset will be used; the offset wasn't changed or adjusted by the aborted trim operation.
- “Out” must be later than “in”** *Cause:* An Edit command has been issued when the Out Point is before the In Point.
- Solution:* Set a new Out Point after the In Point.
- System Unit Clearing Now** *Cause:* A [CLR] + [SYS] command has been entered and confirmed. The SU will reset to default parameters and all setup information will be lost.
- Transport Clearing Now** *Cause:* A [CLR] + [TRAN] command has been issued for the soloed transport. The transport will reset to default parameters.
- Tran:X Play Speed 30 ips** *Cause:* The specified transport speed has changed to 30 ips.
- Tran:X Play Speed 15 ips** *Cause:* The specified transport speed has changed to 15 ips.
- Tran:X Play Speed 7.5 ips** *Cause:* The specified transport speed has changed to 7.5 ips.
- Track is safe or not available** *Cause:* A track record enable command has been ignored because the track has been set to safe or the Micro Lynx system cannot enable it.
- Solution:* Use the setup menu to select and set the track to ready and then set the track to enable.
- WARNING: open end** *Cause:* An Edit command has been issued and no edit Out Point has been entered.
- Solution:* Set an Out Point by using the [F2] key. A time code value can also be entered and stored as the Out Point by pressing [STO] + [OUT].
- WARNING: No active transports enabled** *Cause:* No transports have been record readied in Edit; therefore, the Micro Lynx will not issue the Record or Rehearse commands.
- Solution:* Set one or more transports to record ready by using the [RDY] and machine select keys.

**A, B, or C Does Not Exist** *Cause:* You have tried to solo or group a machine that is unavailable. For example, selecting C when the Machine Expansion Card (M3) option is not installed.

*Solution:* Install a Machine Expansion Card. Verify that the machine setup is correct.

**VITC Lines Changed** *Cause:* The VITC reader is in auto mode and has switched to a new pair of lines because the previously used line pair is no longer available.

*Solution:* Select the required pair of lines, using VITC fixed line mode operation

**VITC Mismatched Lines** *Cause:* The VITC reader is in fixed mode and the time code on the currently selected line pair does not match.

*Solution:* Select a matching pair of lines.

## Prompts

**Hold [GRP] key and add groups in order of priority** *Cause:* Micro Lynx requires that machines are selected to a group for synchronization. If no machines are selected to the group then this prompt is displayed. The GRP LED and the available machine select keys (A-C, TCG) will flash.

*Solution:* Hold the [GRP] key and press machine select keys (A-C, TCG) to make a group. Remember, the machine key selected first will be the reference machine.

**Macro is already programmed. To clear: [MACRO] + [0-9]** *Cause:* You have selected a Macro for programming that is already programmed or has been pre-programmed.

*Solution:* Select a Macro that is blank or press and hold the [MACRO] key and the macro number (0-9) to clear the macro.

**Press [ENTR] to confirm** *Cause:* A data loss function has been selected. Micro Lynx prompts for a confirmation before performing the command. When this prompt is used, the command will involve resetting the system.

*Solution:* Press [ENTR] if you wish to proceed or any other key to exit.

**Program Macro: 0 - - - 4 5  
6 7 8 9** *Cause:* The macro programming function has been entered by pressing [SETUP] + [MACRO]. Macros that are available for programming are displayed.

*Solution:* Press a Calculator key to select a Macro to program.

**Recall mem** *Cause:* [MEM] has been pressed and Micro Lynx is prompting for a memory selection.

*Solution:* Select memory number.

**Recall reg or mem** *Cause:* [RCL] (Recall) has been pressed and Micro Lynx is prompting for a register or memory selection.

*Solution:* Select a valid register or press [MEM] followed by the memory number.

**Select valid reg** *Cause:* Trim mode has been selected and an invalid register or no register is present in the calculator data entry buffer.

*Solution:* Use [RCL] to select the register you want to trim or [CLR] to cancel.

**Set an “in” point** *Cause:* Edit mode has been entered and no edit In Point has been set.

*Solution:* Capture or enter a time code value and store it in the In Point register.

**Solo a grp first** *Cause:* You have attempted to recall or store a sync point or offset register while in group mode.

*Solution:* These operations may only be performed in solo or group status mode. Select solo or status modes and repeat the operation.

**Solo the ref group** *Cause:* A reference sync point can not be captured in group mode or if a slave machine is selected in solo mode.

*Solution:* Solo the reference machine.

**Store reg or mem** *Cause:* The [CAPT] or [STO] keys have been pressed. Micro Lynx is prompting for a valid register or memory number.

*Solution:* Select a valid register or press [MEM] followed by the memory number.

# Chapter 6 Operational Features

---

## Introduction

The Micro Lynx System Unit (SU) and Keyboard Controller (KBD) are used to remotely control two tape machines, in the standard system configuration; using prestripped SMPTE time code for extremely accurate and repeatable transport control. With the optional M3 card, a third tape machine can be added to the system. All machines can function as either master or slave when used in a group. Also any machine within a group can be selected as the time code reference machine and/or the Master machine.

In addition to controlling basic tape movement (play, rewind, fast forward, stop), the Micro Lynx system can also be used to control editing functions (including automated punch in/out for insert recording), multiple memory position autolocate functions, looping and synchronization functions such as offset timing, chase, and search.

In order to control individual tape transports, the correct interface cable must be used to connect the Micro Lynx to each model tape machine. The Appendix lists the remote controllable audio and video tape transports (by manufacturer and model) that are currently controlled by the Micro Lynx. In many cases, a standard serial cable is all that is required, while in others a custom interface cable is required. In each instance the correct cable can be ordered through your TimeLine dealer.

If your tape machine is remote controllable, yet it does not show up on the list, contact Technical Assistance (see the Preface for the Technical Assistance contact information) with the machine's manufacturer and model number to see if it is compatible with the Micro Lynx system.

Other standard features of the Micro Lynx includes versatile time code reader and generator functions, MIDI/SMPTE interfacing, "built-in" video sync option, and expansion to include M3, ACG and VITC Reader option cards.

## SMPTE Time Code Synchronization

Please read through the Appendix section “SMPTE Made Simple” for more information about SMPTE time code.

### Selecting Which Time Code Standard is Right for Your Application

The Micro Lynx can be set to follow, or generate, all of the major time code standards currently in use throughout the world. The time code standard that is correct for your application will be determined by whether you are required to have to lock the audio to film or video.

To set the time code type, enter the Time Code Generator Setup mode (press [SETUP], [TCG and [1/PRE]]). This will bring up the System code menu.

Setup: TCG options
Selection: System Spd/Code: 29.97Hz/30

The left hand number refers to the actual speed in frames-per-second, while the right hand number refers to the type of time code being used. Anytime video is used (as either a reference, or if the audio may be laid back to video in the future), the 29.97 Hz/30 setting should be used. This is the default setting and should be used in virtually all cases in the USA, Japan, and Canada. In other countries, where PAL/SECAM is the broadcast standard, then the 25 Hz/25 setting should be used.

If only audio recording and playback is involved, with no possibility that the audio tracks would need to be synced up with a video machine, or when working in a film only environment, then the 30 Hz/30 setting can be used. Only use the 30 Hz/30 setting when absolutely necessary.

Again, if a video transport is involved anywhere in the production, or if one may even possibly be involved at a later date, then either 29.97 Hz/30 (NTSC) or 25 Hz/25 (PAL) should be your standard SMPTE frame rate.

The Micro Lynx also provides a 24 Hz/24 setting that can be used in the unusual circumstances that a tape is required with code running at film frame rate, then the 24 Hz/24 setting would be used to match the frame rate of film projection systems. Note that the Micro Lynx cannot control film playback devices.

## SMPTE Time Code in the Audio-only Studio

Up to the last few years, the biggest use for synchronization in the audio-only studio was to lock two multitrack tape machines together to increase track capacity. Today many studios are also using SMPTE time code, or its close cousin MIDI Time Code (MTC) as a method to blend virtual tracking--the use of digital audio workstations and MIDI sequencers/synthesizers to create playback elements that don't require laying down sounds to an audio tape, using traditional multitrack audio tape recording techniques.

The most common function for time code, in the audio-only studio, is as a method of syncing up two audio tape machines. To do this, SMPTE or EBU time code must be prestriped onto an edge track (typically the highest number track is used, i.e., track 8, 16, or 24) of the tape in one continuous pass. It is important that the recording level be set following the tape machine manufacturer's recommendations (typically -10 VU with all noise reduction defeated) in order to reliably read the code off the tape during playback, and not have cross-track bleeding of the time code (a continuous high pitched chirping noise or whine in the background is a sign the time code is bleeding across tracks).

Because SMPTE/EBU time code generates a lot of harmonics (due to the square waves that are recorded), many users leave a guard track between audio production elements and the time code track. If this adjacent track must be used, then it is best to record lower frequency instruments like bass or drums onto the track. Note that there are machine configurations (semi-pro 16-track machines using 1/2" tape for instance) where this may not be acceptable even though high frequency EQ or a noise gate are used to minimize SMPTE time code leakage onto the adjacent track's audio.

Each reel of tape should be prestriped with time code before audio production begins so that there is always a continuous sequence of code on each reel. This will simplify machine control and editing, and minimize having to use Jam sync mode later on during playback. (Jam sync is a method used to recover usable time code from a tape that has time code dropouts, poorly recorded time code, or discontinuous time code numbers.)

## Striping the Tape

To stripe a tape with time code, the time code output connector on the back panel of the SU must be connected to the tape machine's time code input for a center track time code machine, or to the edge track dedicated to the time code for a multitrack machine.

When recording time code its important that the capstan be set for WILD rather than RESOLVED mode, meaning that it will run under its own internal speed control. To switch to WILD mode, use the pre-programmed Macro #9 or press [SETUP], then the [TRAN] key twice (to view the Capstan Mode menu). Press the [-] key to change from RESOLVED mode to WILD mode.

Make sure the time code format is properly set. Press [SETUP], [TCG], and the [LAST/NEXT] keys (to select the System Spd/Code menu to verify the setting). Press [SETUP] to go back to normal view mode.

Solo the time code generator to view the current time code value. The time code generator will run from this number. If it is necessary to change it, press [CLR] and then enter the desired start time for the generator (typically 59:45:00). You must then store this new number in the TIME CODE START register by pressing [STO] (store) and [0/TIME].

Set the transport into the record ready mode, press and hold the [RDY] key and then press the transport key (A-C). Now when you press [>] (PLAY) and [REC], the soloed machine will drop into record and the generator will start sending out time code starting at the 0/TIME register setting. Press [>] (PLAY) and [REC] to start recording time code.

Keep in mind that the time code is simply a modulated midband frequency recorded on the tape. This means that it is subject to all the same problems that other audio signals encounter when recorded to magnetic tape including tape dropouts, level shifting, frequency response variances, and distortion caused by dirty, worn, or out of spec heads, transport, or electronics.

These problems will limit the maximum range over which the time code can be read as the transport is shuttled and then stopped. Since the time code changes relative pitch until it is too low (as the tape comes to a stop) or too high (as it is fast shuttled) to be read, ensuring that the heads and electronics are clean and properly aligned will give the maximum performance from the time code track.

**Why Start at 59:45:00?** Starting at 59:45:00 or before (some people like to start at 59:30:00 or earlier) ensures that there will be at least fifteen seconds of time code recorded on tape before the code hits 1:00:00:00 (one hour), which is the default record start point for most projects (although there are those that like to start at 10:00:00:00, in which case the 0/TIME register would be set to 09:59:45:00).

It's essential that you leave at least fifteen seconds of time code at the head of the tape before where the first recording will occur. This blank time code section will be used as the tape's preroll area. Preroll is the amount of time the tape machines roll before the start of audio playback (or recording). It's needed to ensure that all the slave tape machines are locked in sync with the master before the start of audio (or video). For more information on preroll time see "Adjusting the PreRoll Time" in Playback Features, later in this section.

## SMPTE Time Code in the Integrated Video/Audio Production Studio

In most cases the master and/or reference machine will be the video tape machine (VTR) rather than the audio tape machine (ATR). However, as all machines connected to the Micro Lynx are synchronized, any machine can be made the master.

The frame rate selected must match the video standard (29.97 Hz/30 for NTSC, 25 Hz/25 frames for PAL/SECAM). To check and adjust the time code standard press: [SETUP], [TCG], [1]. Use the [+] and [-] keys to step through the frame rate selections.

Another requirement for syncing to video is the connection of a video sync reference to the Micro Lynx's Video Ref jack (a single BNC connector for either input or output). In industry terms this is called the "house sync" connection.

To use house sync as the reference, press [SETUP], [TCG], [0/TIME], and then press the [+] and [-] keys until the external video selection is displayed. Press [SETUP] again to exit this mode.

Setup:	TCG options	
Selection:	System Ref:	ExtVid

If there is no house sync, and this option is selected, the REF LOCK LED will flash indicating there is no reference coming into the BNC connector. If this occurs, the optional Micro Lynx VSG card should be installed so that the Micro Lynx can generate common house sync for the video equipment in the studio. In this case, select the IntFix (internal reference) option rather than ExtVid, then enable the VSG using [SETUP], [TCG], and [6]. If a common house sync is not used then video edits will not be stable.

If highly accurate video positioning is required in pause or still frame mode, then the optional VITC (pronounced as vitsee, Vertical Interval Time Code) card should be installed in the Micro Lynx. This card reads the VITC, time code placed within the video frame, rather than the Longitudinal Time Code (LTC), which is recorded on the Cue, Aux, or second audio track. The VITC card automatically switches between the two modes depending on the speed of the transport and whether VITC is present.

Video transport positioning is much more accurate when using VITC since the LTC drops out when the tape is shuttled very slowly (without the VITC card the Micro Lynx must monitor the capstan control pulses as the LTC drops out).

### Recovering from Bad Time Code and Time Code Dropouts

Before starting a recording session where prestriped tapes are to be used, it's always a good idea to spot check the quality of the time code by locating the machines to several sections of the tape to check that there are no gross problems with the time code. To locate a specific machine to a specific time code point, put it into solo (press [SOLO] and the machine letter, A, B, or C). Press [CLR] and then enter the time code number that the transport should locate to. Press [LOC] (locate). The machine will then fast forward or rewind to the time code position that was entered, minus the time set in the preroll register (1/PRE).

Spot checking the prestriped time code can minimize the chances of encountering locking problems later in the session. Of course, if the tapes were recorded at other facilities and you will be mixing them down, then you may be stuck with substandard quality time code tracks. Such things as an accidental punch-in on the time code track, time code recorded too hot, or too low, or distorted because the Dolby or DBX was not turned off, can all lead to locking problems because the time code cannot be read by the Micro Lynx.

In some instances, the time code may need to be reshaped (cleaned up) or regenerated. The Micro Lynx can do this automatically by using the auxiliary output. The output can be selected from any machine's time code. To select the reshaping function press [SETUP], [TCG], and [5/OFFST]. Use the [+] and [-] keys to select the mode (the default is Reshape 1 or machine A). This output can also send out pilot tone or GPI-2 beeps. Remember, the reshape output is an electronically cleaned up "copy" of the input signal. If the input is not present, a drop out for instance, then the reshaped output signal will also have the same drop out. In this case, regeneration is required.

## Jam Sync Functions

If the Master time code is discontinuous (suddenly changes time code numbers because the tape has been assembled or dubbed from several original master tapes), or there are dropouts in the time code, it may be necessary to “jam” new time code so that there is only one series of time code numbers coming off the tape. Without this replacement time code, the machines will not be able to reliably locate to specific time code points.

To jam new time code, in Setup TCG set the TCG mode to Play, run. Make the transport that needs new time code the Reference transport, and put the machine and the TCG in a group. Play the machine, the TCG will jam to the machine time code numbers and output new code, record this code on a new track on tape.

## Playback Features

### Solo Mode - Single Machine Control Functions

To individually control only one transport, or to check the status of one machine, solo mode is used. When solo mode is selected the upper left display indicates “SOLO:” followed by the machine letter that is currently being soloed (a, b, c, or t). The master machine letter will be in caps, the slave machines will be in lower case letters.

To select only one machine press the [SOLO] key. This turns off the GRP LED and turns on the SOLO LED. Press the individual transport key (a, b, c, or t) to solo that machine. To solo the B transport, for instance, press [SOLO] and then [B]. The resulting display

SOLO:b	.	b→	10:01
		Err:	0.-

shows the current time code setting for the transport (b> 10:01). If the machine is in motion, by pressing the machine key again, the machine error register will be displayed. The error register shows resolve error in play and distance to LOC or Cue in wind modes.

SOLO:b	.	b→	10:01
			6:12:00

Solo mode is also useful for capturing the current time code of the soloed machine to use as a CUE point, edit point or to calculate an OFFSET. All three Micro Lynx machines and the time code generator can be used simultaneously in SOLO. For example, machine A could be in rewind, and b in Play.

## Using Cue Points

The CUE register is a nonvolatile memory location that is typically used to store the time code for a machine start point. It is updated as one works through a mix or editing session to set a new start time so that all the machines can be located back to that specific time, in order to play back through the edits or mix changes.

### Setting the Cue Register

The Cue register is set with the current number shown in the calculator section of the display (lower right display). This number can be manually entered using the keypad, or it can be captured from any machine or recalled from another memory register. To save the displayed number as the new Cue location press [STO] (store), then [CUE].

### Using the Cue Register

The Cue register can be used to locate one machine, if that machine is soloed, or a group (when the GRP LED is on) to the Cue time by simply pressing [CUE]. All machines will then go to the Cue time (minus any preroll time set in the Preroll register).

The Cue register setting can be checked by pressing [RCL] and [CUE]. This displays the current Cue time code setting in the lower right display:

a b C* t	C→	59:45:00
	Cue:	59:45:00

Pressing [CUE] while in play will force the machine(s) to rewind (or fast forward) to the Cue time. The machine(s) will then stop and park at the Cue time (minus any preroll time that is set).

The Cue register can be cleared (to 00:00:00:00) by pressing and holding the [CLR] key and then pressing [CUE].

## Group Mode - Multiple Machine Control

In order to synchronize and control multiple transports they must be placed into a group. A group is made up of one or more transports that are controlled together such that one is designated the master machine and the rest are slave machines. All machines in the group are timed from a reference machine, which does not necessarily have to be the master machine.

A group can also contain the Time Code Generator (TCG), which is treated just like another transport or machine in that it can be selected as part of a group, and it can be soloed, just like the other three transports (A, B, and C). The TCG output is typically used to drive an automation system, workstation, sequencer or other time code chase device, so it syncs up to the master. This can be used to control MIDI synthesizers, lighting, special FX, or any other time-based sequential action.

When grouping machines, it is important to remember that the first machine selected in a new group will become the reference and master machine. The reference machine has an asterisk (\*) displayed next to it in the display. The reference machine defines the time code type and position that the system will use. All the other machines in the group follow the reference machine position. Thus, unless all the machines have the exact same starting time code (like 01:00:00:00), each machine will need to have an offset added or subtracted to properly track the reference machine. The system also uses and slaves the reference machine's time code numbers when entering any locate, start, stop, or punch in/out times for the group.

The master machine is indicated by a capital letter, while all the other machines in the group will be in lower case. In addition to listing which machines are in a group and which machine is the master and which is the reference, the display also indicates with a "+", any machines that have offsets applied to them.

### Create a Group

To create a completely new group, you must first erase the group. Press and hold [GRP] (group select), then press [SETUP]. This will erase any previous group settings and cause the GRP, A, B, C (if the M3 card is installed), and the TCG LEDs to flash. The display will read:

Hold the "GRP" key, and add  
groups in order of priority

The first machine that is selected in this new group will now be the reference machine for the group. It is selected by holding down the [GRP] key while pressing [A], [B], [C], or [TCG]. This first machine is also the master machine for this group. Continue holding the [GRP] key and select the remaining machines for this group. The remaining machines will display as lower case letters indicating their slave machine status.

## Changing the Master Machine

If required, the Reference and Master can be different machines. Set the Group option - Ref follow Master - to off and then select a new master machine by holding the [SETUP] key and then pressing the desired new master machine key (A, B, C, or TCG). Since this does not affect the reference machine, the \* stays with the original transport. See the Getting Started and Keyboard Controller sections for more information.

**Note:** By default the Ref follow Master option is set on. If the Master is changed, the Reference machine will also change.

There can only be one master machine in a group. The master machine is the one that is activated by the motion controls. When it starts to move, the slave machines will immediately start up as well in order to lock up to the master.

## Resetting the Group

The current group status can be reset by holding the [GRP] key and then pressing the [SETUP] key. This allows the user to designate a new group from the default display. The display will read:

Hold the "GRP" key, and add groups in order of priority
--

## Machine Offsets

In almost all but the basic application, the time code at the start of the tape on the reference machine will not match the time code at the start of the other machine's tapes. Because even a small difference will cause locating problems when the machines are put into a group, the reference machine's start point time must be subtracted from each machine's start point time code to come up with an amount of time to use as an offset.

### Setting the Offsets

Once the reference, master, and slaves are designated in a group, each machine must be soloed and moved to their "starting" point. This can be done fairly roughly right now, to just get them close to their starting points. Once each transport is set at their start time, press [CAPT] to transfer their time code to the calculator display, and then [5/OFST], to automatically calculate the offset from the reference machine. You will still see the original time code numbers in the display for each machine since the Micro Lynx does all the offset calculations internally.

To fine tune the offsets, press the [GRP] key to regroup the machines and play the group. When the machines have locked, press the machine ([A]-[C], [TCG]) key that needs to be fine tuned. This will change the display to STAT. Press [TRIM] to activate the jog wheel. The machine offset register is automatically selected. Rotate the jog wheel clockwise or counter clockwise to adjust the offset in one-frame steps until the sound or picture or event matches the reference machine. If one-frame steps are too big, then press [SUBFR] (sub-frame). This changes the jog wheel to 1/100 frame steps as it is turned. You may also use the [+] and [-] keys to change the offset. Offset trimming can also be done in the stop mode.

To check the offset for any machine, solo or stat that machine, then press [RCL], [5/OFST]. This will display the offset (in plus or minus time code numbers) from the reference machine.

## Machine Control

In a group, the master machine is always started first and the slaves follow and lock to the master. As the slave tape machines take a finite amount of time to catch up and lock to the master, a pre-roll time can be set to compensate for this delay (which varies considerably between machines).

## Adjusting the PreRoll Time

The preroll time is the amount of time one sets for the tape machines to get up to speed and in sync with the master before the desired audio play/record start point. The default preroll setting is five seconds (5:00). This setting is stored in the preroll register ([1/PRE] key). Its current setting can be checked by pressing the [RCL] (recall register) and the [1/PRE] calculator key. The lower right section of the display will then show the preroll setting (PRE: 5:00 the default).

If instead, four seconds of preroll is all that is required for slave machines, press the [4], [0], and [0] calculator keys to enter 4:00, then press the [STO] (store) and [1/PRE] keys to store the new preroll time.

The preroll setting is subtracted from whatever time code location the tape is being shuttled to. For instance, if the time code 1:00:20:00 was entered, and the tape was located to this time (using the [LOC] key), the actual stop time of the tape would be 1:00:20:00 minus the preroll time, or 1:00:15:00, when using the default preroll setting of five seconds. When play is pressed the tape begins rolling from the preroll time so that all transports are properly locked together by 1:00:20:00.

## Adjusting Postroll Time

The postroll default setting is also set to five seconds (5:00). This is the amount of time that the tape will continue to roll at the end of an edit sequence. Its value is held in the postroll register ([2/POST]). The current setting can be viewed by pressing the [RCL] and [2/POST] keys.

If the value needs to be changed, simply enter the new value using the calculator keypad, then press the [STO] (store) and [2/POST] keys to enter the new value into the register memory.

## How To Edit Loop a Group of Machines

If the Micro Lynx is set to group mode, initiating loop play will play all machines in the group.

There are three loop option questions that need to be answered before initiating loop play. What should happen after an edit is performed (redo the edit sequence or simply replay the edited sequence)? What should happen after a replay (does the machine stop or does it continue to repeat the replay)? And, what happens if the machine is set to stop after a replay (should the machine simply stop or rescue itself)?

Press [SETUP], [LOOP] and [0] to bring up the After Edit setting. Press [+] or [-] to select Re-Edit or Replay. Re-Edit repeats the edit once again unless stop is pressed. Replay rewinds the tape and plays back the edit.

Pressing [1] brings up the After Replay setting. Press the [+] or [-] key to select End or Repeat. If end is selected then the machine will stop after the tape is replayed. If repeat is selected then the machine will continue to either go through the replay sequence.

If end is selected in option 1, press [2] to set what happens when the End of the loop sequence is reached. Use the [+] or [-] keys to select between stopping the tape at the edit end point, or recuing the tape to the edit start point.

## Recording Functions

### Using an Auxiliary Footswitch for Punch-In/Out Control

Normally punch in and out points are set beforehand so that the exact record start and record end times are known before recording is initiated. When performing and recording live music it may be easier to do this “on the fly” by using a footswitch than to take the time to set up punch in and out points. The Installation section outlines what is required to set up a footswitch to perform punch ins and outs.

To use the footswitch you must preset the appropriate tracks to the record ready state (see next section). Simply put the machine(s) into play, and, at the appropriate time, step on the footswitch to switch the record ready machine into record. Step on the switch a second time to turn off recording.

### Setting Record Ready Options

Setting a machine to drop into record is a two step process; you must first record enable the machine by pressing and holding the [RDY] key and then the appropriate transport letter key (A, B, or C). This will flash the red record ready LED for that machine. To deselect a single machine, press and hold the [RDY] key and then select the machine a second time. To take all machines out of record ready, press and hold [CLR], then press [RDY].

On machines that accept individual track enables tracks must now be put into track ready mode by pressing [TRKS] and then the appropriate machine letter (A, B, or C) to bring up the track select display. Since ATRs and DTRs may have anywhere from 2 to 48 tracks, and VTRs may have from one to four audio channels in addition to individually being able to record video, time code, or

sync, there will be several variances between displays, depending upon the model of machine selected.

In any machine, individual tracks are selected by simply using the calculator keypad to select the tracks (after selecting the machine using the [TRKS] and machine letter key). In a VTR, pressing [0] by itself will set the video ready to record, pressing [6] will set the time code track ready to record, pressing [5] puts the machine into record ready on the sync or cue track, and pressing [9] puts the machine into the assemble edit mode.

To select additional audio tracks simply press the appropriate number pad key. If more than eight channels of audio are available on a machine, the jog wheel can be used to scan through the tracks and the [+] and [-] keys used to select or disable record ready on each track. Using the [Last] and [Next] keys will also step through the tracks, and [CLR] will change the track ready status back to safe.

Chapter 8 (Keyboard Controller) gives more details on using the record ready function.

To ensure that all tracks on a transport are in the safe mode, select that transport using the [TRKS] and transport letter keys, and then press and hold CLR while pressing the [TRKS] key. This will clear any track enables, putting all tracks back into the record safe mode.

## Keyboard Operations

### Using the Jog Wheel for Trim Operations

The jog wheel can be used not only to jog and shuttle the tape in the transport mode, but can be used for setting some setup option variables.

### Using the Memory Registers

The Micro Lynx has 100 general purpose memory registers used for storing time code numbers. These numbers are placed into the calculator display when they are recalled so they can be used with CUE, LOC, and other functions where a time code number would normally be entered on the calculator keypad.

Most users prefer using the ten memory register option. The advantage is that each register requires only one key press (the ten registers are labeled 0 through 9). Using the one hundred memory register option requires a two-digit entry for every register (the registers are labeled 00 to 99).

## Storing Numbers in the Memory Registers

Before storing numbers, check the current memory size setting by pressing the [SETUP], then the [MEM] key. The display will show the current memory size.

Setup: Memory options
Selection: Memory Size: 0-9

Use the [+] and [-] keys to select between the ten memory option (0-9) and the one hundred memory option (00-99). Press [SETUP] to exit this mode.

To store a time code number in a memory register:

1. Press [CLR] to clear any numbers in the calculator display.
2. Type in the time code number to be saved.
3. Press the [STO] (store) key.
4. Press the [MEM] (memory) key.
5. Press one key from 0-9 if using the ten memory option. Press two keys (00-99) for every register when using the one hundred memory option. Note: the [00] key cannot be used for memory location 0 or 00.

## Recalling Memory Register Contents

To transfer the memory contents to the calculator display press [MEM] (the MEM and RCL lights will flash) and the register number. The display will show the memory register number and its contents in the calculator display area.

Mem00: 1:00:00:00
-------------------

The number can then be used as a locate time code number (LOC) for a transport or group, or it can be stored into another register (CUE, SYNCP, IN, OUT, etc.).

The memory register contents cannot be erased individually, but they can be written over by using [STO]/[MEM]. To clear all the memory registers requires the clear all memory/reset command, ([CLR] + [SETUP], then [ENTR], [CLR]).

## Programming Macros

To quickly change or preset several options or modes at once, users can store all the necessary key presses in a Macro register. The Macro function is actually recalling the key presses, in the order that they are stored in the Macro memory register. When a

Macro is recalled, the Micro Lynx responds just as if you were actually pressing the keys.

**Note:** These are not “smart” Macros. They don’t know what mode was selected before the first key was pressed, nor do they know the settings of the menu options or anything else. All they can do is record a series of key presses and then play them back exactly as you pressed them.

Thus, if a Setup option is being changed, you must include enough [+] or [-] key presses to ensure the option is set to the top or bottom of the option list before going back to the option choice you want. You should also try to always enter and recall Macros from a known mode or state (i.e., in the stop mode, with group selected, jog and shuttle off, setup off, etc.). In this way you will get the desired results since the Macro does not know where you’re starting from. Be sure to write down your Macro key presses so that if they get erased you can easily reenter them.

There are ten Macro registers. Several are loaded with instructions from the factory (although these can also be written over with your own Macros). The [F1] and [F2] keys recall the Macros stored into Macro registers 1 and 2. These two Macros can be recalled with the touch of only one key ([F1], [F2]), while the other eight Macros require two key presses, the [MACRO] key and the register number (0-9), to be recalled. There is a limit of approximately 40 key presses for each Macro, so choose your Macros carefully to minimize the number of key presses required.

---

**CAUTION:**

When recalling Macros be sure to always release the [MACRO] key completely (it will flash) before pressing the register number key, as inadvertent Macro erasure can occur.

---

## Deleting a Macro

To enter new information in a Macro it must be cleared first. To erase the contents in a Macro register, press and hold the [MACRO] key. Then press the register number (0-9) to delete the contents. See the above Caution to prevent accidentally erasing a Macro.

## Using the Preprogrammed Macros

Five of the nine Macro registers come preprogrammed with commonly used functions. To use these function simply press [F1], [F2], or [F3] for registers 1 and 2. To recall registers 8 and 9 you must first press [MACRO] then the number.

The registers contain the following instructions from the factory :

- Register 0:** Blank
- Register 1:** Capture and store the current transport time code number (upper right part of the display) in the IN register.
- Register 2:** Capture and store the current transport time code number in the OUT register.
- Register 3:** Blank
- Register 4:** Blank
- Register 5:** Blank
- Register 6:** Blank
- Register 7:** Blank
- Register 8:** Exits the time code striping mode. Resets the transports back to their normal mode (capstan resolved).
- Register 9:** Time code striping mode. Sets the transports connected to the Micro Lynx ready to be prestripped with time code (their capstans are set to WILD). It stops with the SETUP/TCG/1 menu displayed.

## Programming Your Own Macros

Press [SETUP] and then [MACRO] to list the Macros that are available for programming. The numbers that are displayed are those that are free and can be programmed. The dash indicates that Macro has information stored in its register and is not available for programming, unless it is cleared first.

## Program Macro: 0 - - - 4 5 6 7 - -

Press one of the number keys that is available. The display will return to normal view and the MACRO light will flash. Perform the function(s) you'd like to store in the Macro. All your key presses will be stored in the selected Macro. Press the [MACRO] key again to complete programming the Macro.

As an example, here's how to program the PRE-roll time for ten seconds and the POST-roll time for two seconds, and then store these changes in the Macro 4 register.

1. Press [SETUP], [MACRO], [4] (this tells the Micro Lynx that you want to store the following key presses in the Macro 4 register).
2. Press [CLR] (to zero out the calculator display).
3. Press [1], [0], [00], [STO], [1/PRE] (this enters 10:00 into the calculator, and then stores it into the Preroll register).
4. Press [CLR] (to zero out the calculator display).
5. Press [2], [00], [STO], [2/POST] (this enters 2:00 into the calculator display, and then stores it into the Postroll register).
6. Press the [MACRO] key (this ends the Macro entry and stores the key presses into the Macro 4 register).

To recall this key sequence again, press [MACRO] then [4] and the new Preroll and Postroll times will be entered into the appropriate registers. The calculator display will show the Postroll time since that was the last action entered in the Macro.

## Setting Variable Speed Playback

There are two system reference settings that can be used for variable playback speed; VSO, where the system follows the master machine's time code speed, or the Micro Lynx Internal variable mode, which can be selected as the reference speed source. In the display window these two selections would show up as "V" for VSO mode, or "i" for the Internal variable mode.

To select the system synchronization reference mode press [SETUP], [TCG], and [0]. Use the [+] and [-] keys to step through the selections (IntFix, IntVar, ExtVid, Aux, VSO, ACG). In the IntVar mode, the speed can be varied between 87.5% and 112.5% of nominal speed. To set the Int Var varispeed, press the [2/POST] key to bring up the Varispeed menu. Press the [+] or [-] keys (or use the jog wheel) to change the speed, press [SETUP] again to exit the TCG setup menu.

## Code Only Master Operation

Sometimes it becomes necessary to synchronize a machine, or group of machines to a time code source. This type of operation is commonly referred to as code only master - allowing a Master machine's time code source to position slave machines into resolve and lock. This section explains the various methods of operation available with the Micro Lynx that will allow code only master operation.

### Selecting the System Reference

Two reference choices are available for code only master operation: VSO (variable speed operation) and External Video. The correct selection will depend on the types of machines being used.

If the time code source will come from an analog, or non-video referenced machine, then the System Reference selection will be VSO Master. This mode will allow the time code source to provide the speed reference for the transports being synchronized. Please be aware that this type of reference selection will only be as reliable as the incoming master time code source. Any irregularities in speed will be applied to the synchronized slave machines.

**Note:** A video transport CANNOT be slaved to a time code only master with VSO Master as the system reference.

If the time code source is from a video deck, or a video deck will be slaved to the incoming time code source, then the System Reference must be EXTVID. In this mode, the time code source must run at the proper video speed.

**Note:** A digital audio transport can only be slaved to a code only master source when the time code source AND the digital machine are both referenced to the same external sync. In some cases, the ACG-2 option card can be applied to this type of operation.

### Setting the Master Machine Type

In a code only master operation, it is generally assumed that the time code source machine cannot be synchronized by the Micro Lynx. This can occur for several reasons: the time code source generates from a remote location, or the machine is not remotely controllable by the Micro Lynx. In either case, the Master machine transport setup menu selection becomes important.

The transport menu selection for the code only master machine MUST be set to an analog machine type setting. Do not select a video or digital transport type. Any analog setting will do.

## Transport Control

In a code only master setup, group machine control will originate from the incoming master machine's time code. As the Micro Lynx Keyboard controls cannot be used, the deck-plate, or machine remote transport keys must be used. Whenever the time code source is played, slave machine chase and lock will be initiated. A slave offset may be necessary to position the slave machine(s) correctly.

Please note that the automated editing capabilities of the Micro Lynx Keyboard will not function, since the Micro Lynx is not remotely controlling the master machine.



# Chapter 7 System Unit

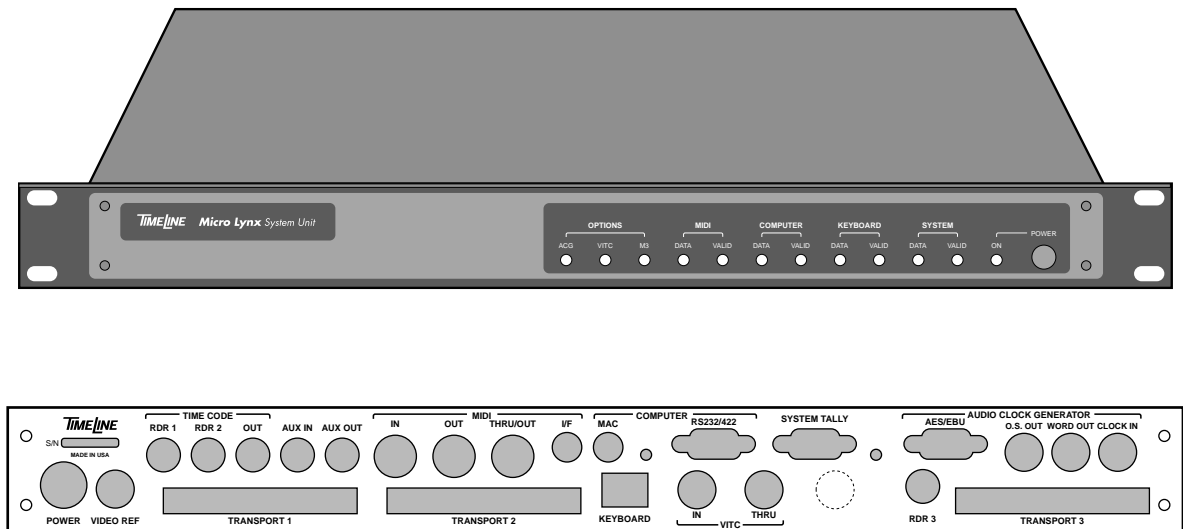

BACK PANEL

MIK060B

Figure Chapter 7 -1. System Unit

## Introduction

The System Unit contains the main processors, software and control circuitry for Micro Lynx. It oversees all of the operator selected operations, communications between equipment, signal conversion and generation. It also contains all of the stored transport specific data, conversion tables, formulas, and time codes for performing operations.

## Front Panel Indicators and Switches

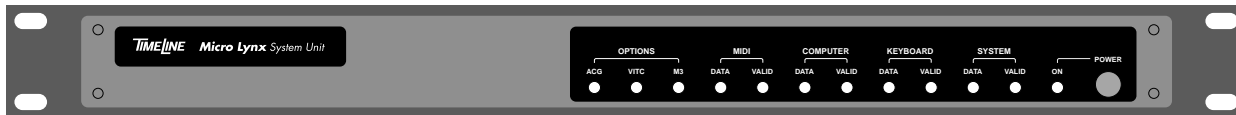

MIK011A

Figure Chapter 7 -2. Front Panel Indicators and Switches

### OPTIONS

- ACG** When turned on, a Digital Audio Clock Generator Card is installed. There are two versions of the card:
  - ACG-1 Word Clock and Oversample Clock Outputs
  - ACG-2 The same as ACG-1 but with AES/EBU clock inputs and silent output. Word clock or AES/EBU can be used as a system reference.
- VITC** When turned on, the VITC Reader Card is installed.
- M3** When turned on, the Third Machine Expansion Card is installed and you may add a third transport to the system.

### MIDI

- DATA** This LED indicates that communications signals are passing between the System Unit (SU) and connected MIDI equipment.
- VALID** When turned on, it indicates valid serial data is present on the link between the System Unit and the MIDI equipment.

### EXTERNAL COMPUTER

- DATA** This LED indicates that communications signals are passing between the System Unit and an external computer.
- VALID** When turned on, it indicates valid serial data on the link between the System Unit and external computer equipment.

### KEYBOARD

- DATA** When on, this LED indicates that communications signals are passing between the System Unit and the Keyboard Controller.
- VALID** When turned on, it indicates valid serial data on the link between the System Unit and the Keyboard Controller.

## SYSTEM

**DATA** When on, this LED indicates that communications signals are passing internally between the control processor and the other processors in the System Unit.

**VALID** When turned on it indicates valid internal serial data communications.

## POWER

**ON** When on this LED indicates that power is being supplied to the System Unit.

**Note:** If a DATA LED is flashing or turned off, this indicates that there is a hardware problem. First turn off the power and check all cables and connections. It should be corrected after powering up the system. If a VALID LED is flashing or turned off, there is a software or communications problem. Press [CLR] + [SYS] then [CLR] + [SETUP] to reinitialize the SU and KBD. Verify that the external control devices are correctly configured.

## Video Reference

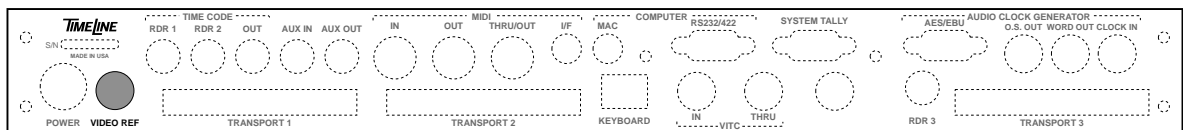

MIK036B

Figure Chapter 7 -3. Video Reference

**VIDEO REF** BNC, single-ended input. This combined input/output supports PAL and NTSC video sync references.

If the TimeLine internal composite Video Sync Generator card (VSG) is installed, then the connector is used as an output to provide video reference for DTRs, VTRs, and Digital/Audio Workstations connected to the system.

If the system is selected to EXT VID reference then this connector is used as an input. Use a black burst or composite video sync source to reference the system to video.

It is not possible to select the TimeLine VSG if an External Video reference is selected.

To select the external or internal video reference source, see the Keyboard Section of this manual.

# Transport Connectors

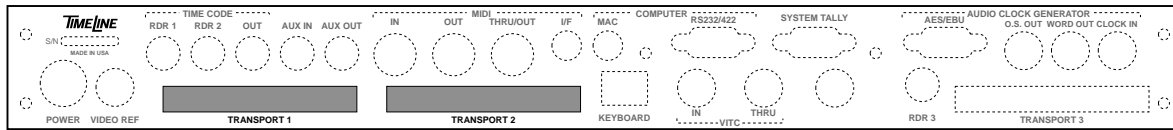

MIK012B

**Figure Chapter 7 -4. Transport Connectors**

**TRANSPORT 1, 2** 40-pin, dual inline headers. All machine control signals pass through this 40-pin input/output port. The transport control signals, capstan servo signal, and machine tallies needed for the transport to correctly operate and synchronize are on this connector.

See the Installation Chapter or TRAN under SETUP in the Keyboard Controller chapter for information on how to select the transport type and configure this connector for your machine.

**Table Chapter 7 -1. Transport Connector Pin Description**

Pin	Description	Pin	Description
1	Ground	2	Transport Ground Sense
3	Ground	4	Assemble
5	Fast Forward	6	Rewind
7	Mute	8	Pull-up common
9	Record Tally	10	Tach
11	+ 5 V	12	Servo relay B, normally closed contact
13	Rehearse	14	Video Track Enable (INS)
15	Ground	16	Ground
17	Play Tally	18	Audio Track Enable (A2)
19	RS422, TX-	20	RS422, TX+
21	RS422, RX-	22	RS422, RX+
23	Record Exit	24	Search Enable
25	Aux In	26	Search Control Voltage
27	Capstan Frequency	28	Tape Direction
29	Servo Relay B, Normally Open Contact	30	Capstan Control Voltage
31	Record In	32	Servo Relay B Common
33	Audio Track Enable (A1)	34	Servo Relay A Common
35	Lifter Enable, In/Out	36	Command Common
37	+12 V	38	-12 V
39	Stop	40	Play

## Time Code Readers and Generator

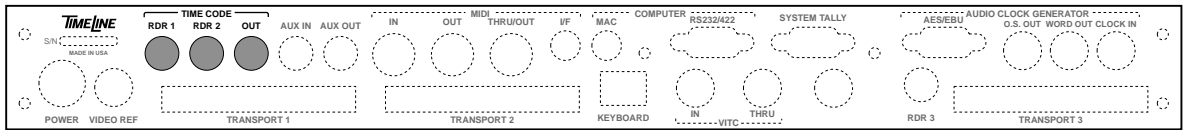

MIK019B

Figure Chapter 7 -5. Time Code Readers and Generator

**RDR 1, 2** 1/4" stereo jack differential input. Time code inputs for transports 1 and 2. Readers 1 and 2 are wideband high speed linear time code inputs with a speed range from 1/10 speed to 60x play speed.

Table Chapter 7 -2. RDR 1 Time Code Connector Pin Description

Pin	Description
Tip	Time Code Reader 1+
Ring	Time Code Reader 1-
Sleeve	Ground

Table Chapter 7 -3. RDR 2 Time Code Connector Pin Description

Pin	Description
Tip	Time Code Reader 2+
Ring	Time Code Reader 2-
Sleeve	Ground

**OUT** 1/4" stereo jack unbalanced output. Time Code output for software selectable, multi-standard time code generator. It has a fixed output level of -1 dBm (1.4V pp).

Table Chapter 7 -4. Time Code OUT Connector Pin Description

Pin	Description
Tip	Time code generator +
Ring	Ground
Sleeve	Ground

# MIDI

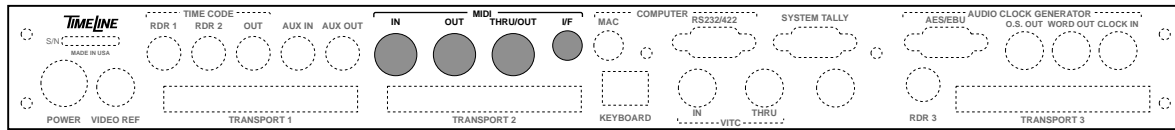

MIK013B

**Figure Chapter 7 -6. MIDI**

**IN** 5-pin DIN socket. MIDI input is used to read MIDI time code (MTC) from an external MIDI device.

**Table Chapter 7 -5. MIDI IN Connector Pin Description**

Pin	Description
1	NC
2	Ground
3	NC
4	MIDI In+
5	MIDI In-

**OUT** 5-pin DIN socket. The MIDI output is used when the Micro Lynx generates MIDI Time Code.

**Table Chapter 7 -6. MIDI OUT Connector Pin Description**

Pin	Description
1	NC
2	Ground
3	NC
4	MIDI Out+
5	MIDI Out-

**THRU/OUT** 5-pin DIN socket. Used as a MIDI output or to retransmit MIDI input information.

**Table Chapter 7 -7. MIDI THRU/OUT Connector Pin Description**

Pin	Description
1	NC
2	Ground
3	NC
4	MIDI Out+
5	MIDI Out-

**I/F** MAC to MIDI Interface. Mini 8-pin DIN MAC serial connector is

used to directly connect the Micro Lynx to a MAC serial modem or printer port. An external MIDI interface box is not required. The Micro Lynx has a nominal interface speed of 1 MHz. Select the correct serial port and interface speed from the MAC MIDI application. This connector is used when the Micro Lynx generates MIDI time code

**Table Chapter 7 -8. I/F Connector Pin Description**

Pin	Description
1	1 MHz clock (Bi-polar)
2	NC
3	Adapter Out-
4	Signal Ground
5	Adapter In-
6	Adapter Out+
7	NC
8	Adapter In+

## Computer

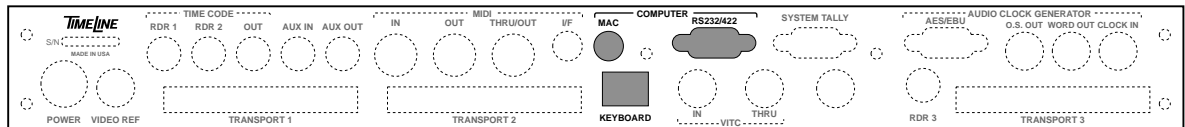

MIK014B

**Figure Chapter 7 -7. External Control Interface**

**MAC** Mini 8-pin connector. Connects to a standard MAC serial peripheral port. We recommend using the modem port because the computer gives it priority over the printer port when checking for activity. The Micro Lynx serial interface conforms to RS422 standards and has an interface speed of 1 MHz.

**Table Chapter 7 -9. I/F Connector Pin Description**

Pin	Description
1	1 MHz clock (Bi-polar)
2	NC
3	Adapter Out-
4	Signal Ground
5	Adapter In-
6	Adapter Out+
7	Frame Clock $\pm 5v$ at system reference
8	Adapter In+

**RS232/422** 9-pin 'D' type socket. The Micro Lynx supports both major EIA standards: RS232C and RS422.

The RS232 transmitter modulates a signal with respect to a common ground (bipolar). The receiver senses whether the signal is sufficiently negative with respect to ground to determine a logical 1 which makes it susceptible to noise and interference. As a consequence, RS232C can only be used over short distances.

The RS422 transmitter modulates the signal against an inverted copy of the same signal (i.e., a differential signal). The receiver senses which line is more negative than the other. Because the signal is differential, it is more immune to noise and interference and will not degrade over significant distances.

**Table Chapter 7 -10. RS232/422 Connector Pin Description**

Pin	Description
1	Ground
2	RS 422, Tx-
3	RS 422, Rx+
4	RS232, Tx
5	Frame Clock at system reference, open collector signal
6	Ground
7	RS422, Tx+
8	RS422, Rx-
9	Frame Clock, $\pm 5$ V at system reference

**KEYBOARD** Standard RJ-45 telephone socket. Power, data, and communications between the TimeLine System Unit and the Keyboard Controller pass through this port.

**Table Chapter 7 -11. Keyboard Connector Pin Description**

Pin	Description
1	+12V
2	+12V
3	KBD RX+
4	KBD RX-
5	KBD TX+
6	KBD TX-
7	Ground
8	Chassis

## System Tally, Aux In, Aux Out

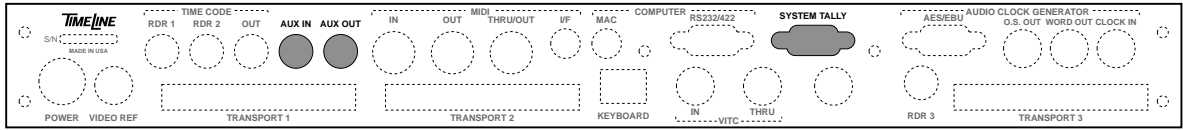

MIK015B

Figure Chapter 7 -8. System Tally and Aux Jacks

**SYSTEM TALLY** 9-pin 'D' plug. This port supports GPI 1 and GPI 2 events, relays, mute relay, and the system lock tally indicator light.

Table Chapter 7 -12. System Tally Connector Pin Description

Pin	Description
1	Ground
2	System Lock light, open collector signal
3	Mute Relay +
4	GPI 2 Relay +
5	GPI 1 Relay +
6	+5 V, 50 mA current limited
7	Mute Relay -
8	GPI 2 Relay -
9	GPI 1 Relay -

**AUX IN** 1/4" socket, differential input. Used for the Pilot In reference signal.

Table Chapter 7 -13. Aux In Connector Pin Description

Pin	Description
Tip	Auxiliary reference In+
Ring	Auxiliary Reference In-
Sleeve	Ground

**AUX OUT** 1/4" socket, unbalanced output. This output signal has a fixed output level of -1 dBm (1.4V pp) and is software selectable. Selections include:

- Reshape time code RDR 1
- Reshape time code RDR 2
- Reshape time code RDR 3
- Pilot out
- Dialog beep out

See TCG options under SETUP in the Keyboard Controller chapter for information on how to select the Aux Output signal.

**Table Chapter 7 -14. Aux Out Connector Pin Description**

<b>Pin</b>	<b>Description</b>
Tip	AUX Output +
Ring	Ground
Sleeve	Ground

The Pilot Output signal is locked to and at the same rate (60, 59.94, 50, 48 Hz) as the system reference.

The dialog beep output is a 1 kHz oscillator that follows the pulsed timing parameters set for Events GPI-2. See SETUP TCG options under SETUP in the Keyboard Controller chapter for information on how to select the Aux Output signal.

## Third Machine Interface

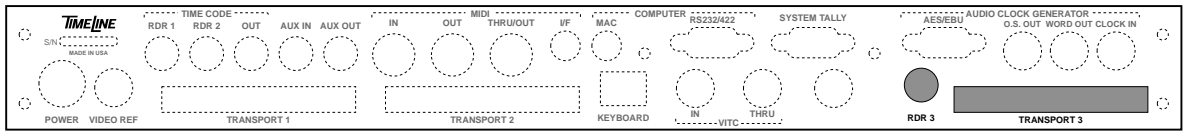

MIK016B

**Figure Chapter 7 -9. Third Machine Interface**

**TRANSPORT 3** 40-pin, dual inline header. All machine control signals pass through this 40-pin input/output port. The transport control signals, capstan servo signal, and machine tallies needed for the transport to correctly operate and synchronize are on this connector.

See the Installation Chapter or TRAN under SETUP in the Keyboard Controller chapter for information on how to select the transport type and configure this connector for your machine.

**Table Chapter 7 -15. Transport 3 Connector Pin Description**

Pin	Description	Pin	Description
1	Ground	2	Transport Ground Sense
3	Ground	4	Assemble
5	Fast Forward	6	Rewind
7	Mute	8	Pull-up common
9	Record Tally	10	Tach
11	+ 5 V	12	Servo relay B, normally closed contact
13	Rehearse	14	Video Track Enable (INS)
15	Ground	16	Ground
17	Play Tally	18	Audio Track Enable (A2)
19	RS422, TX-	20	RS422, TX+
21	RS422, RX-	22	RS422, RX+
23	Record Exit	24	Search Enable
25	Aux In	26	Search Control Voltage
27	Capstan Frequency	28	Tape Direction
29	Servo Relay B, Normally Open Contact	30	Capstan Control Voltage
31	Record In	32	Servo Relay B Common
33	Audio Track Enable (A1)	34	Servo Relay A Common
35	Lifter Enable, In/Out	36	Command Common
37	+12 V	38	-12 V
39	Stop	40	Play

**RDR 3** 1/4" stereo socket, differential input. Wideband linear time code input for transport 3 with a speed range is of 1/10 to 60x play speed.

# Audio Clock Generator

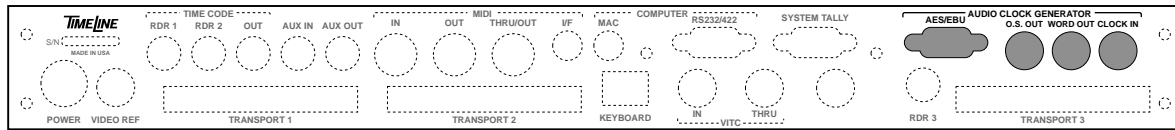

MIK017B

**Figure Chapter 7 -10. Audio Clock Generator**

The Audio Clock generator is a multi input/output digital audio clock card that can be either locked to or generate the Micro Lynx system frame reference. See ACG under SETUP in the Keyboard Controller Chapter for information on how to set up the ACG options.

**Table Chapter 7 -16. AES/EBU Connector Pin Description**

Pin	Description
1	Ground
2	AES/EBU In-
3	Ground
4	AES/EBU Out-
5	Ground
6	AES/EBU In+
7	Ground
8	Ground
9	AES/EBU Out+

**AES/EBU** 9-pin 'D' socket, transformer coupled. AES/EBU digital input and output connector. Will output a silent AES/EBU bit stream locked to the system reference with either a fixed or variable ratio to the nominal sample rate. Will accept an AES/EBU input which can be used as a system reference. ACG-2 Option card only.

**OUT** BNC, +5V TTL level output. The Oversample Clock Output is locked to the system reference with a frequency determined by the word clock rate and the oversample output multiplier.

**WORD OUT** BNC, +5V TTL level output. The Word Clock Out is locked to the system reference with either a fixed or variable ratio to the nominal sample rate.

**CLOCK IN** BNC, +5V TTL level input. The Digital Audio Word or Oversample Clock input is used with the oversample input demultiplier to provide a system reference. ACG-2 Option card only.

# VITC

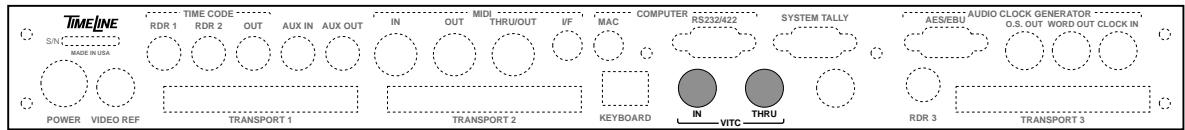

MIK018B

Figure Chapter 7 -11. VITC Interface

**IN** BNC, differential input. Connected to the output from the video machine.

**THRU** BNC. Loop through of the video input connector.

# Power

SYSTEM UNIT BACK PANEL

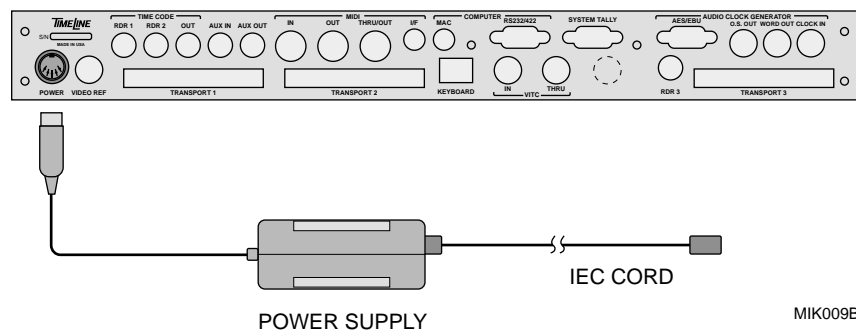

MIK009B

Figure Chapter 7 -12. Power

**POWER** 5-pin DIN socket. Power is supplied to the Micro Lynx System Unit by an external power supply. Do NOT add an extension to the 5-pin DIN cable between the Power Supply and the System Unit.

Table Chapter 7 -17. POWER Connector Pin Description

Pin	Description
1	Ground
2	Ground
3	+5 V
4	-12 V
5	+12 V

**Power Supply** The Power Supply Unit is a switched mode type, which automatically adjusts to the correct AC voltage for your area. It is suitable for operation at any voltage in any country.



# Chapter 8 Keyboard Controller

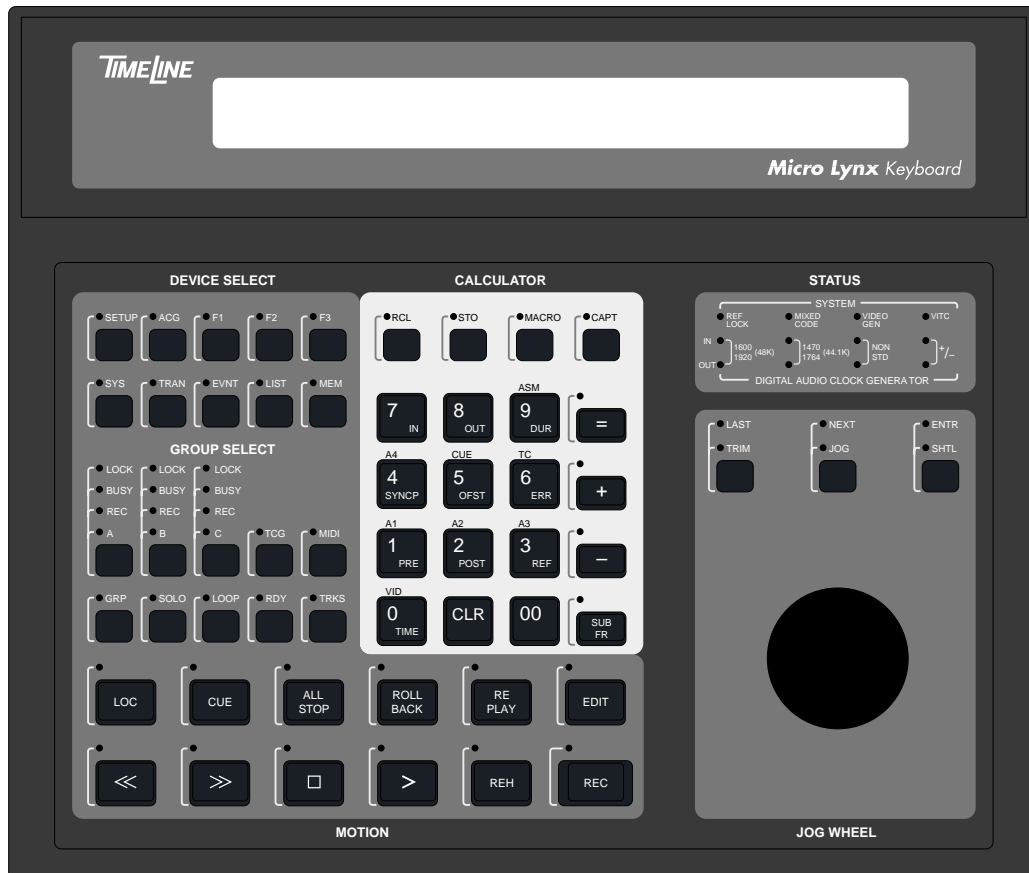

MIK037A

Figure Chapter 8 -1. Front Panel

## Introduction

This chapter identifies the eight functional blocks for the Micro Lynx Keyboard. The function of each key and indicator is described in detail. The functional blocks described are:

- |                         |                    |
|-------------------------|--------------------|
| Display                 | Transport Controls |
| Jog/Shuttle Wheel       | Device Select      |
| Group Select            | Calculator         |
| Auxiliary Function keys | Status Indicators  |

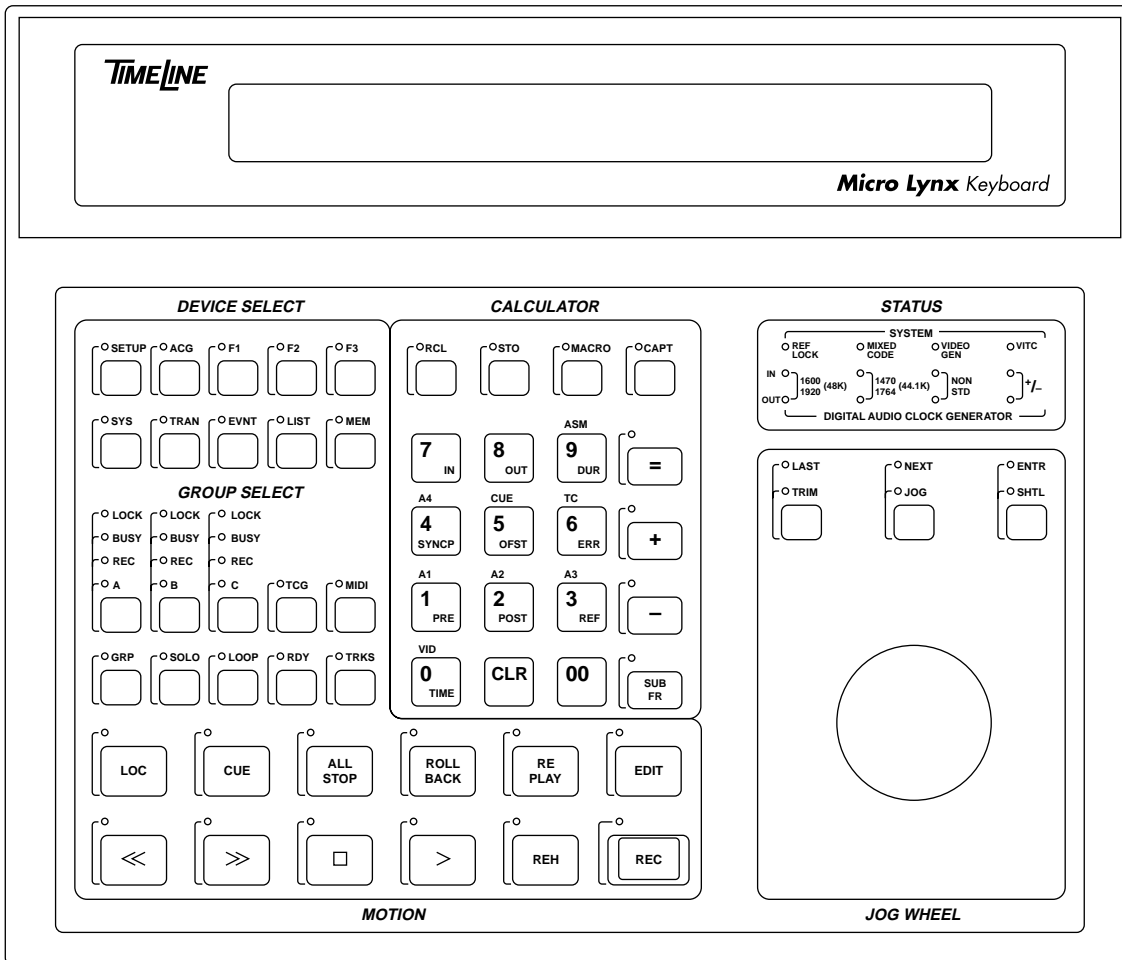

MIK044A

Figure Chapter 8 -2. Keyboard Key Locator

**Table Chapter 8 -1. Key Mnemonics**

<b><u>Key Mnemonic</u></b>	<b><u>Description</u></b>	<b><u>Key Mnemonic</u></b>	<b><u>Description</u></b>
<b>DEVICE SELECT</b>		<b>CALCULATOR</b>	
SETUP	Setup	RCL	Recall
ACG	Audio Clock Generator	STO	Store
F1	Function Key 1	MACRO	Macro
F2	Function Key 2	CAPT	Capture
F3	VITC	CLR	Clear
SYS	System	SUB FR	Subframe
TRAN	Transport	-	Minus or move 1 increment backward
EVNT	Event	+	Plus or move 1 increment forward
LIST	List	=	Equals
MEM	Memory	00	Double Zero
<b>GROUP SELECT</b>		0 TIME	VID
A	Machine A (Transport 1)	1 PRE	A1
B	Machine B (Transport 2)	2 POST	A2
C	Machine C (Transport 3)	3 REF	A3
TCG	Time Code Generator	4 SYNCP	A4
MIDI	MIDI Time Code	5 OFST	CUE
GRP	Group	6 ERR	TC
SOLO	Solo	7 IN	
LOOP	Loop	8 OUT	
RDY	Record Enable	9 DUR ASM	
TRKS	Tracks		
<b>MOTION</b>		<b>STATUS</b>	
LOC	Locate	REF LOCK	Speed Reference is Locked
CUE	Cue	MIXED CODE	Mixed Code
ALL STOP	All Stop	VIDEO GEN	Video Generator
ROLL BACK	Roll Back	VITC	VITC
REPLAY	Replay	<b>JOG WHEEL</b>	
EDIT	Edit	TRIM, LAST	Trim or Last menu selection
<<	Rewind	JOB, NEXT	Jog or Next menu selection
>>	Fast Forward	SHTL, ENTR	Shuttle or Enter
■	Stop		
>	Play		
REH	Rehearse		
REC	Record		

# Display

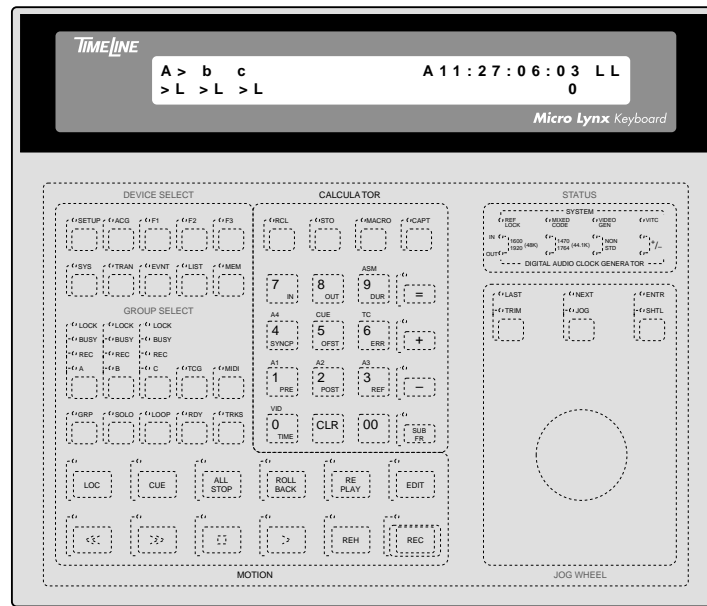

MIK020A

Figure Chapter 8 -3. Display

The Micro Lynx uses an 80 character Liquid Crystal Display (LCD). Several categories of information are displayed:

1. Normal Operating Display
2. Calculator Display
3. Register Contents
4. Setup Displays
5. Prompts and Error Messages

The display can be conceptually divided into four quadrants. Each area provides a specific type of information.

*(upper left)* Machine Information      *(upper right)* Time Code

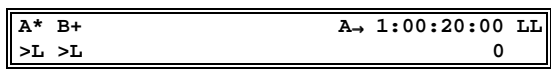

*(lower left)* Machine Status      *(lower right)* Calculator

**Machine Information** This area identifies which machines are selected and if master or slave status. **A\* b+** A capital letter (A) indicates the master, an asterisk (\*) indicates the reference machine, a small letter (b) indicates a slave machine, and a plus sign (+) indicates that a machine has an offset.

**Time Code** Time code for the selected machine is displayed. Leading zeros are not displayed. For example, 3 minutes, 13 seconds, and 2 frames:  
**11:27:06:03 LL**

00:03:13:02

is displayed as:

3:13:02

Drop frame code is indicated by separating the seconds and frames digits with a comma rather than a colon. For example, if the time code above is drop frame it would be written as:

3:13,02

**Machine Status** This area indicates the tape machine transport status. **>L** indicates that the machine is in lock. Other status mnemonics include:

<<	Rewind	CUE	Cueing	R	Record
>>	Fast Forward	RLB	Rollback	r	Rehearse
< >	Jog/Shuttle	LOC	Locate	Ch	Chase
•	Stop	REP	Replay	NC	No Code

**Calculator** This area of the display is active whenever any of the calculator keys are pressed or a time code register or memory is recalled.  
**0**

## Normal Operating Display

The normal operating display is displayed once the Micro Lynx has been initialized. For example,

### Solo Mode

```
SOLO: A >L                A-11:27:06:03
                                0
```

### Group Mode

```
A* B+                A-11:27:06:03 LL
>L >L                0
```

**A** Indicates which machine is selected. Status information is displayed for that machine.

A capital letter (A) indicates that the machine selected is the master. Remember, any machine can be the master.

A lower case letter (b) indicates that the machine selected is a slave.

An asterisk (\*) indicates that the machine is the time code reference.

A plus (+) indicates that the machine is offset from the reference transport.

An >L indicate that it is in play and locked. An >W indicates that the machine is in wild speed. That is, the Micro Lynx is controlling the machine, but not synchronizing it.

**11:27:06:03** Time code for the group or selected machine.

**LL** Indicates whether the machine or group are in lock and which system reference they are locked to. This example uses LL; the following reference designations are also used:

I	Internal Fix
i	Internal Variable
L	External Video
P	Aux
V	VSO
A	ACG

In group mode two letters are displayed. The first letter indicates that the master machine is locked to the system speed reference. The second letter indicates that all of the other machines in the synchronized group are locked.

## Calculator Display

When any of the Calculator keys (00-9) are pressed, the digit is displayed in the calculator scratch pad located in the lower right area of the display.

A	A-10:00:20:00
>L	11:27:06:03

- 0 The calculator can be used to perform time code additions or subtractions. In the following example an addition is performed.

### Procedure

1. [1], [1], [2], [7], [0], [6], [0], [3]

SOLO:A	A-10:00:00:00
	11:27:06:03

Enter a time code number.

2. [+] (plus)

SOLO:A	A-10:00:00:00
	plus 0

Select a calculator mode. The operation selected is displayed

3. [1], [0], [0], [0]

SOLO:A	A-10:00:00:00
	10:00

Enter a time of 10 seconds.

4. [=]

SOLO:A	A-10:00:00:00
	11:27:06:03

The sum is displayed in the lower right.

## Register Contents

The Calculator keys also provide access to time code register values. Values may be stored to or recalled from any of the 10 registers.

SOLO:A	A→00:00:00:00
	(A) In: 11:27:06:03

**STO (Store)** Press [STO] in the calculator key section to store a time code value to a Micro Lynx register. Next press the appropriate calculator register key to select the register to store the value in. The time code to be stored can be determined in one of several ways: it may be captured, entered, or calculated. If the [CAPT] key is used to capture a time code value then the store function is automatically invoked.

**RCL (Recall)** Press [RCL] in the calculator key section to recall and display values stored in a Micro Lynx register. Next press the appropriate calculator register key to display the register value. For example, to examine the in point register, press [RCL] followed by [IN] (7). The register contents will be displayed in the calculator data entry area.

### Procedure

1. [RCL]

*RCL LED flashes*

Recall reg or mem	A→10:00:00:00
-------------------	---------------

Enter recall mode.

2. [IN] (7)

SOLO:A	A→10:00:00:00
	(A) In: 11:27:06:03

Look at the value stored in the in point register. RCL LED turns off.

## Setup Display

In Setup mode, you may access any of the user preference option menus to customize the Micro Lynx.

```

Setup: System options
Selection: LED Brightness: 100%

```

To access the individual menus, press [SETUP], then the appropriate menu select key. On the Micro Lynx, you can select the following keys to access their respective menus.

ACG	SYS	TRAN	EVNT	MEM
TCG	GRP	LOOP	RDY	TRKS
ROLLBACK	EDIT	REC	REH	MACRO

To move through the Setup menus use the following keys:

- [LAST]/[NEXT]. Selects the next or previous item in a top level menu (i.e., machine manufacturers).
- [ + ]/[ - ]. Selects the next or previous item in the selected menu (i.e., machine types).

### Procedure

1. [SETUP]

```

Setup:
Selection:

```

You have entered Setup mode.

2. [REC]

```

Setup: Key options
Selection: Record by: Play + Rec

```

Select the [REC] Key, there are 2 options (+ and -).

3. [ + ]

```

Setup: Key options
Selection: Record by: REC only

```

Dual key record, operation begins by pressing [REC] and [PLAY] simultaneously.

4. [ - ]

```

Setup: Key options
Selection: Record by: Play + Rec

```

Single key record operation, begins by pressing [REC] only.

5. [SETUP]

```

Hold the "GRP" key, and add
groups in order of priority

```

Exit and save the record key selection.

## Prompt & Error Display

The Micro Lynx has a comprehensive prompt/message system that guides the user in various operational situations. For example:

```
Hold the "GRP" key, and add
groups in order of priority
```

A concise message is flashed momentarily on the display to prompt an action, provide description, suggestions, and status information.

If a system error occurs, the [SYS] key will flash. A complete list of error messages is located in Chapter 5, Troubleshooting.

Press [SYS] to display the error messages. The SYS LED will turn on and the first error message will be displayed until you press [SYS] again. Pressing [SYS] again displays the next error message. After the last error is displayed, the errors are cleared and the error mode is automatically exited. The SYS LED flashes until all of the errors have been cleared. Press [CLR] to exit SYS mode at any point without erasing the list.

### Procedure

1. SYS LED flashing

When the SYS LED flashes, a system error or change has occurred.

2. [SYS]

```
1:Communications error:
```

The first error message in the error stack or list is displayed. Note the message as you will be asked for this information by the factory, if you are unable to correct the problem.

3. [SYS]

```
2:System Frames changed
```

Press [SYS] again to see the next error message and to exit when the list is done. The Micro Lynx holds error messages in a stack, when the top message is removed, the next one is displayed. Repeat step 3 until all messages have been read.

4. [CLR]

```
SOLO:A >L           A->      11:27 LL
                        0
```

Press [CLR] to exit SYS mode at any point without erasing the list.

## Transport Controls

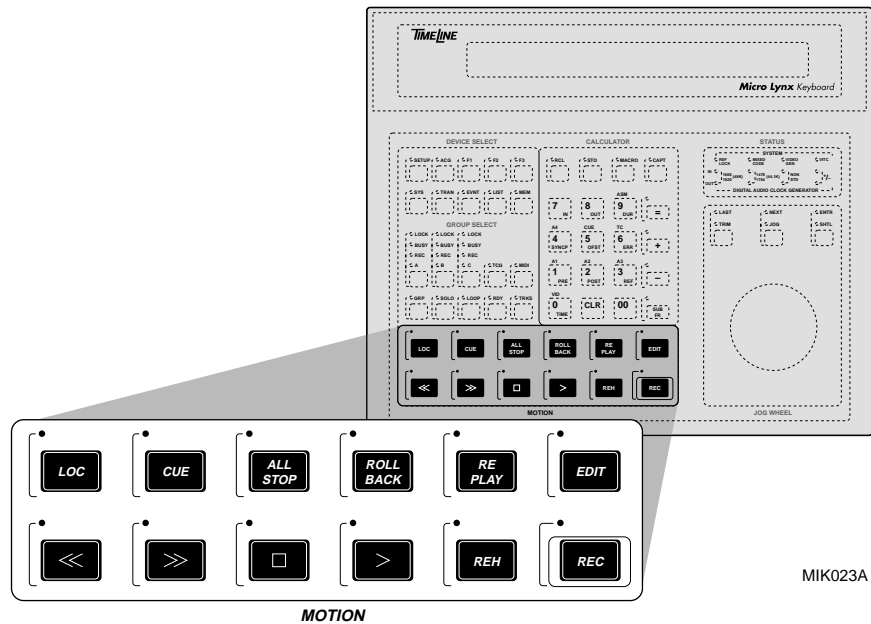

MIK023A

Figure Chapter 8 -4. Motion Control Keys

**LOC (Locate)** In solo mode, Micro Lynx will locate the soloed machine to the time code in the calculator data entry area, minus the system preroll.

In group mode, it will locate all transports currently assigned to the group to the time in the calculator data entry area, minus the system preroll.

**CUE** In solo mode, Micro Lynx Cues the soloed machine to the time code in the cue point register.

In group mode, it cues all machines currently assigned to the group to the time code stored in the cue point register. If a cue point is not set, then the Micro Lynx will use the in point register. If there is no cue point or in point set, the following message is displayed:

No in point or cue point set

**ALL STOP** The [ALL STOP] key issues an immediate Stop command to all transports on the system regardless of group status, solo status, or transport mode. All machines will stop. This key is used as a “panic button” to stop unexpected transport operations.

**ROLLBACK** The [ROLLBACK] key rewinds the selected machine or group by a predetermined amount. The default rollback value is 15 seconds. The rollback time can be changed by entering a new value then pressing the [STO] and [ROLLBACK] keys.

The [ROLLBACK] key can also be used as a reverse play key for transports that will play backwards. To change the [ROLLBACK] key to PLAY REV, enter the Key options menu by pressing [SETUP] followed by [ROLLBACK]. Use the [+] and [-] keys to select the desired function.

**REPLAY** The [REPLAY] key is used in conjunction with the [EDIT] key to replay the current edit. Pressing [EDIT] followed by [REPLAY] cues the selected machines in the group to cue to the current edit preroll position and commence an edit replay sequence.

The [REPLAY] key has an associated replay register that stores the time code when the [>] (PLAY) key was last pressed. Pressing [REPLAY] causes a locate to the time code when the [>] (PLAY) key was last pressed.

***Remember** that pressing [>] (PLAY) while the machines are playing, can be used to update the replay register and set a new replay register time code.*

**EDIT** The [EDIT] key initiates a Micro Lynx edit sequence. It is used in combination with the [REC], [REH], [REPLAY], and [CUE] keys. Before pressing [EDIT], use the [F1] and [F2] macro keys to define the edit in and out points. When the Edit command is issued, the Micro Lynx cues the machines to a preroll or cue point and puts the machines into play. At the edit in point the record or rehearse command is issued. The machines continue to roll until the edit out point is reached, a REC OUT command is issued to exit record or rehearse. The machines run for a postroll period and stop. If the [LOOP] key is selected, the machines will recue and repeat the process (see Loop and Setup • Loop for loop options).

Press the [EDIT] key to enter the edit routine. Select an edit mode, the REC, REPLAY, REH, and CUE LEDs will flash to prompt selection of one of the edit options. The display shows the edit status as it runs. An example is presented in the Getting Started chapter.

**REC.** Initiates a record edit sequence. Machines will cue, roll and go into record at the edit in point.

**REH.** Initiates a rehearse edit sequence, machines will cue, roll, and go into rehearse at the edit in point.

**REPLAY.** Initiates a replay edit sequence; machines will cue and roll only.

**CUE.** Machine will locate to the cue or preroll point and park.

**EDIT.** Stops or cancels edit mode.

**Edit Sequence**

1. Preroll time counts down.
2. The edit command is displayed and the duration counts down, the postroll counts down and the machines stop.
3. If loop is selected, the edit recues and repeats.

In edit, record and rehearse, the Micro Lynx GPI's and dialog beep oscillator can be selected to operate at the edit in point (see EVNT under Device Select key for further information on the GPI relays). In edit replay these GPI's are disabled.

**<< (Rewind)** In solo mode, the Rewind command is issued only to the machine that is soloed.

In group mode, the Rewind command puts all machines currently assigned to the group into rewind or chase.

**>> (Fast Forward)** In solo mode, the Fast Forward command is issued only to the transport that is soloed.

In group mode, the Fast Forward command puts all transports currently assigned to the group into fast forward or chase.

**■ (Stop)** In solo mode, the Stop command is issued only to the machine that is soloed.

Pressing [■] (stop) in group mode initiates an intelligent stop function. The master machine stops immediately. Then each slave machine is parked at a position that corresponds to the master machine's position taking individual offsets into account. The system is cued and ready to synchronize.

**> (Play)** In solo mode, the Play command is issued only to the machine that is soloed.

In group mode, the Play command puts machines currently assigned to the group into play.

In play, the Micro Lynx synchronizes and locks each of the machines including the master machine to the system speed reference. When the master machine is locked, a letter appears after the time code in the display. This letter also indicates the specific system speed reference that the machines are locked to.

- I** Internal Fixed - the Micro Lynx internal crystal (default)
- i** Internal Variable - the Micro Lynx internal frequency synthesizer
- L** External Video - source of video sync
- P** Aux - pilot tone
- V** VSO - varispeed, the master machine's play speed
- A** ACG - digital input signal to the Audio Clock Generator

When all machines have achieved lock, a second letter is displayed. A sample sequence might be as follows:

**Procedure**

1.

```
A* b c           A→ 1:01:14:07
. . .           0
```

The default display shows solo or group mode and the current time code location.

2. [>] (PLAY)

```
A* b c           A→ 1:01:42:17 I
>L > >         0
```

Time code should be running. The master is locked to the internal fixed reference.

```
A* b c           A→ 1:01:14:07 II
>L >L >L       0
```

A second 'I' is displayed when all machines are locked to the internal fixed reference.

**REH** In solo mode, the Rehearse command is issued to the soloed machine if it is record enabled and in lock.

In group mode, the Rehearse command is issued to all machines currently assigned to the group that are record enabled, if the group is locked.

The Rehearse command can be issued manually by pressing the [REH] key or by pressing the [REH] and [PLAY] keys together (see Setup to alter the REH command option). The Rehearse command can also be issued automatically as part of the Micro Lynx edit routine.

The [REH] key has an associated REH LED. In solo mode, the REH LED indicates the rehearse status of the soloed machine. In group mode, the REH LED indicates the rehearse status of all the machines currently assigned to the group. If any machine in the group is in rehearse, then the REH LED is turned on.

**REC** In solo mode, the Record command is issued to the soloed machine if it is record enabled and in lock.

In group mode, the Record command is issued to all machines currently assigned to the group that are record enabled, if the group is locked.

The Record command can be issued manually by pressing the [REC] key or by pressing the [REC] and [PLAY] keys together (see Setup to alter the REC command option). The Record command can also be issued automatically as part of the Micro Lynx edit routine.

The [REC] key has an associated REC LED. The Micro Lynx machine interface cables monitor the actual record status of each machine. The REC LED is a true record tally. When turned on, it indicates that the machine is actually in record.

In solo mode, the REC LED indicates the record status of the soloed machine. In group mode, the REC LED indicates the record status of all the machines currently assigned to the group. If any machine in the group is in record, then the REC LED is turned on.

# Jog/Shuttle

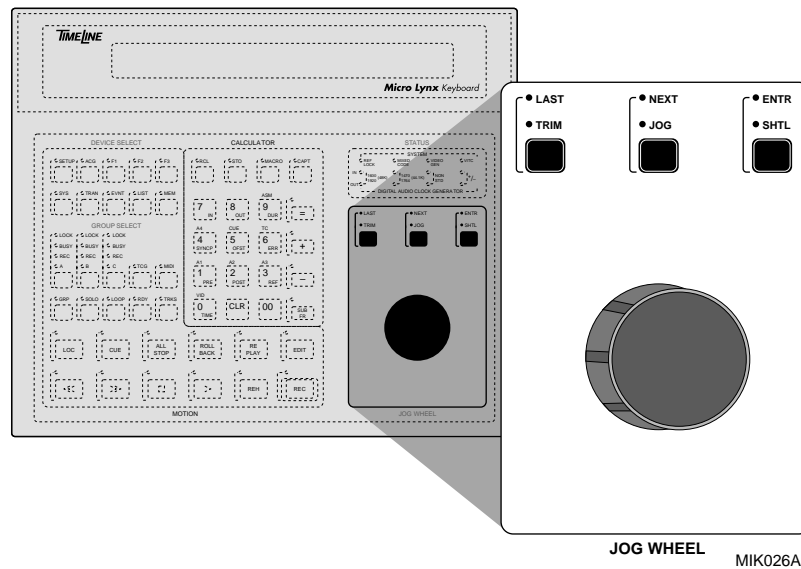

Figure Chapter 8 -5. Jog/Shuttle

## Jog/Shuttle Wheel

The Jog/Shuttle Wheel has three modes: Trim, Jog, and Shuttle. It can be used to

- Spool machines at controlled wind speeds.
- Nudge or bump a tape one frame at a time.
- Trim the offset of a source machine in real time to achieve a precise time relationship between the master and slave machines.

## TRIM/LAST

**TRIM** The [TRIM] key selects Trim mode, use the Jog Wheel and the [+] and [-] keys to adjust register values. You may adjust the values in most registers. After selecting trim, recall a register; then press the [+] or [-] keys, or use the Jog Wheel to increase or decrease the time code value. Holding [+] or [-] down will cause the key to auto-repeat.

Press the [SUB FR] key to enter subframes and use the Jog Wheel or [+] and [-] keys to adjust the subframe value. For example, you may need to finely adjust an offset value. Select a slave machine and recall the offset, press [SUB FR] then [TRIM]. Use the Jog Wheel to adjust the value. Press [TRIM] again to exit trim mode.

Each time that you press [TRIM], the Micro Lynx selects the last register that you trimmed. Press a register key on the calculator keypad to select a different register to trim.

The following keys are also active with TRIM:

[CLR] Clears any number from the data entry area of the display and exits trim mode.

[STO] Initiates a Store command and prompts for a register to store to.

**LAST** In setup mode, the [TRIM] key is used as the [LAST] key. This key steps backwards to the previous item in a menu.

## JOG/NEXT

**JOG** In the Jog mode, the wheel is used to “bump” a transport forward (clockwise) or backward (counter-clockwise) a small amount each time that it is turned. If you turn the wheel continuously, the tape will “scrub” past the heads with a velocity proportional to how fast you turn the wheel.

**NEXT** In setup mode, the [JOG] key is used as the [NEXT] key. This key steps forward to the next item in a menu.

## SHTL/ENTR

**SHTL** In the Shuttle mode, turning the wheel clockwise causes the selected machines to move forward with a velocity that is proportional to the amount that you rotate the wheel from its starting position. Likewise, turning the wheel counter-clockwise initiates variable-speed backwards motion. The Shuttle speed may be varied from a slow crawl to several times normal play speed.

Generally speaking, the Shuttle mode is a controlled speed mode only on video transports. Most audio tape machines do not have a variable speed shuttle mode, so the shuttle function is implemented by rapidly toggling between rewind and fast forward. The actual velocity is determined by the ballistics of the particular machine.

Shuttle is most effectively used in the solo mode to accurately position a single machine for setting sync points, in points and out points. If you use the Shuttle function in group mode, the wheel controls only the master machine; all other machines will chase the master machine and attempt to maintain their correct park-ahead offset.

**ENTR** The [ENTR] key is used to confirm operations that may cause a loss of data or setup information. For example, [CLR] + [SYS] will reset the System Unit, [ENTR] is used to confirm this action.

## Device Select Keys

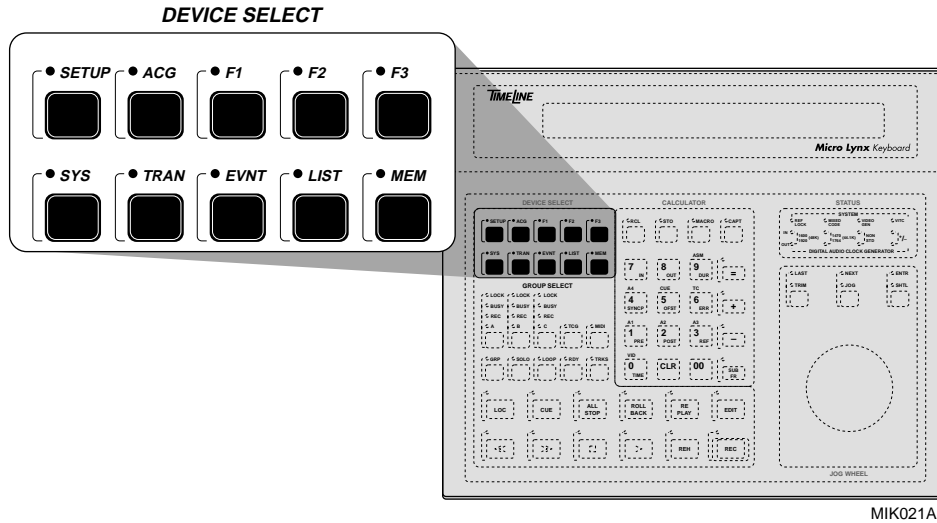

Figure Chapter 8 -6. Device Select Keys

The Device Select keys determine the system operating mode, set system, transport, GPI and Audio Clock Generator card operating parameters, and other system functions.

## SETUP

The Micro Lynx has a comprehensive setup procedure for customizing the system for a particular mode, transport or application. The setup options are organized by function in a menu type format with 14 option categories:

<b>Key</b>	<b>Category</b>
ACG	Audio Clock Generator
SYS	System
TRAN	Transport
EVNT	Events
MEM	Memory
TCG	Time Code Generator & System Reference
GRP	Group
LOOP	Loop
RDY	Record Ready
TRKS	Tracks
KEY	Rollback, REH, REC Operation
EDIT	Edit
MACRO	Program Macro
F3	VITC Reader

Press the [SETUP] key to enter Setup mode. Next, select the category that you wish to modify. After modifying the selected option, exit Setup mode by pressing [SETUP] a second time. Each item in a particular menu can be accessed either directly by

selecting it numerically or sequentially by pressing the [LAST] and [NEXT] keys. Step through the menu options by pressing the [+] and [-] keys. The setup key options are provided in the following table.

Table Chapter 8 -2. Setup Key Description

<p>[SETUP]</p> <p>[ACG] ACG OPTION</p> <ul style="list-style-type: none"> <li>[0] NOM S/RATE OUT             <ul style="list-style-type: none"> <li>32.000 Ks/s</li> <li>[+/-] 44.056 Ks/s</li> <li>[+/-] 44.100 Ks/s</li> <li>[+/-] 47.952 Ks/s</li> <li>[+/-] 48.000 Ks/s</li> </ul> </li> <li>[1] VAR RATIO OUT             <ul style="list-style-type: none"> <li>OFF</li> <li>ON</li> </ul> </li> <li>[2] VAR RATIO OUT %             <ul style="list-style-type: none"> <li>85%-115% (100.00%)</li> </ul> </li> <li>[3] OVERSAMPLE OUT             <ul style="list-style-type: none"> <li>128</li> <li>[+/-] 192</li> <li>[+/-] 256</li> <li>[+/-] 384</li> </ul> </li> <li>[LAST/NEXT] [4] NOM S/RATE IN             <ul style="list-style-type: none"> <li>32.000 Ks/s</li> <li>[+/-] 44.056 Ks/s</li> <li>[+/-] 44.100 Ks/s</li> <li>[+/-] 47.952 Ks/s</li> <li>[+/-] 48.000 Ks/s</li> </ul> </li> <li>[5] VAR RATIO IN             <ul style="list-style-type: none"> <li>OFF</li> <li>ON</li> </ul> </li> <li>[6] VAR RATIO IN %             <ul style="list-style-type: none"> <li>87.5%-112.5% (100.00%)</li> </ul> </li> <li>[7] OVERSAMPLE IN             <ul style="list-style-type: none"> <li>128</li> <li>[+/-] 192</li> <li>[+/-] 256</li> <li>[+/-] 384</li> <li>OFF</li> </ul> </li> <li>[8] REFERENCE IN             <ul style="list-style-type: none"> <li>[+/-] AES/EBU</li> <li>[+/-] CLOCK IN BNC</li> </ul> </li> </ul> <p>[EDIT] EDIT OPTION</p> <ul style="list-style-type: none"> <li>[0] EDIT Q/C             <ul style="list-style-type: none"> <li>DISABLE</li> <li>RETRY</li> <li>STOP</li> </ul> </li> <li>[1] EDITS ROLL AS             <ul style="list-style-type: none"> <li>MAST/SLAVE</li> <li>ALL SLAVES</li> </ul> </li> </ul> <p>[EVENT] SELECT GPI OPTIONS <sup>1</sup></p> <ul style="list-style-type: none"> <li>[1] GPI 1             <ul style="list-style-type: none"> <li>NORMAL</li> <li>AUTOSET</li> <li>REC TALLY</li> <li>EDIT REC</li> <li>REH TALLY</li> <li>EDIT REH</li> <li>LOCK TALLY</li> </ul> </li> <li>[2] GPI 2             <ul style="list-style-type: none"> <li>[0] MODE                 <ul style="list-style-type: none"> <li>NORMAL</li> <li>AUTOSET</li> <li>REC TALLY</li> <li>EDIT REC</li> <li>REH TALLY</li> <li>EDIT REH</li> <li>LOCK TALLY</li> </ul> </li> <li>[1] BEEP MODE                 <ul style="list-style-type: none"> <li>OFF</li> <li>ON</li> </ul> </li> <li>[2] BEEP SPACING                 <ul style="list-style-type: none"> <li>10-30 (20)</li> </ul> </li> <li>[3] LAST BEEP                 <ul style="list-style-type: none"> <li>MUTED</li> <li>ON</li> </ul> </li> </ul> </li> </ul>	<p>[GRP] GROUP OPTIONS</p> <ul style="list-style-type: none"> <li>[0] SEARCH MODE             <ul style="list-style-type: none"> <li>CHASE</li> <li>GROUP</li> </ul> </li> <li>[1] REF FOLLOW MSTR             <ul style="list-style-type: none"> <li>OFF</li> <li>ON</li> </ul> </li> <li>[2] GROUP PARKHEAD             <ul style="list-style-type: none"> <li>0-30 (25)</li> </ul> </li> <li>[3] GRP LED STATUS             <ul style="list-style-type: none"> <li>NORMAL</li> <li>TIMCODE</li> </ul> </li> </ul> <p>[LOOP] LOOP OPTIONS</p> <ul style="list-style-type: none"> <li>[0] AFTER EDIT             <ul style="list-style-type: none"> <li>RE-EDIT</li> <li>REPLAY</li> </ul> </li> <li>[1] AFTER REPLAY             <ul style="list-style-type: none"> <li>END</li> <li>REPEAT</li> </ul> </li> <li>[2] AFTER END             <ul style="list-style-type: none"> <li>STOP</li> <li>RECUE</li> </ul> </li> </ul> <p>[MACRO] PROGRAM MACRO</p> <ul style="list-style-type: none"> <li>[0-9] (1,2,3,8 &amp; 9)</li> </ul> <p>[MEM] MEMORY OPTION</p> <ul style="list-style-type: none"> <li>MEMORY SIZE             <ul style="list-style-type: none"> <li>0-9</li> <li>00-99</li> </ul> </li> </ul> <p>[MIDI] MIDI OPTIONS</p> <ul style="list-style-type: none"> <li>[0] MIDI OUT JACK             <ul style="list-style-type: none"> <li>OFF</li> <li>MTC</li> <li>MIDI DATA</li> <li>MTC + DATA</li> <li>I/F THRU</li> </ul> </li> <li>[1] I/F OUT JACK             <ul style="list-style-type: none"> <li>OFF</li> <li>MTC</li> <li>MIDI DATA</li> <li>MTC + DATA</li> <li>MIDI THRU</li> </ul> </li> <li>[2] MAC OUT JACK             <ul style="list-style-type: none"> <li>OFF</li> <li>MTC</li> <li>MIDI DATA</li> <li>MTC + DATA</li> </ul> </li> <li>[3] MIDI THRU JACK             <ul style="list-style-type: none"> <li>MIDI IN</li> <li>MIDI OUT</li> </ul> </li> <li>[4] MTC SOURCE             <ul style="list-style-type: none"> <li>MIDI IN JACK</li> <li>I/F JACK</li> <li>MAC JACK</li> </ul> </li> <li>[5] MIDI DATA SRC             <ul style="list-style-type: none"> <li>MIDI IN JACK</li> <li>I/F JACK</li> <li>MAC JACK</li> </ul> </li> <li>[6] MIDI RESOLVE             <ul style="list-style-type: none"> <li>OFF</li> <li>ACG SERVO</li> </ul> </li> </ul> <p>[RDY] RECORD OPTIONS <sup>2</sup></p> <ul style="list-style-type: none"> <li>[0] REC ADV 30-IN             <ul style="list-style-type: none"> <li>0-255</li> </ul> </li> <li>[1] REC ADV 30-OUT             <ul style="list-style-type: none"> <li>0-255</li> </ul> </li> <li>[2] REC ADV 15-IN             <ul style="list-style-type: none"> <li>0-255</li> </ul> </li> <li>[3] REC ADV 15-OUT             <ul style="list-style-type: none"> <li>0-255</li> </ul> </li> <li>[4] REC ADV 7.5-IN             <ul style="list-style-type: none"> <li>0-255</li> </ul> </li> <li>[5] REC ADV 7.5-OUT             <ul style="list-style-type: none"> <li>0-255</li> </ul> </li> </ul>	<p>[ROLLBACK, REH, REC] KEY OPTIONS <sup>3</sup></p> <p>[ROLLBACK] OR [0] ROLLBACK KEY</p> <ul style="list-style-type: none"> <li>[+/-] ROLLBACK</li> <li>[+/-] PLAY-REV</li> </ul> <p>[REH] OR [1] REHEARSE BY</p> <ul style="list-style-type: none"> <li>[+/-] PLAY+REH</li> <li>[+/-] REH ONLY</li> </ul> <p>[REC] OR [2] RECORD BY</p> <ul style="list-style-type: none"> <li>[+/-] PLAY+REC</li> <li>[+/-] REC ONLY</li> </ul> <p>[SYS] SYSTEM OPTIONS</p> <ul style="list-style-type: none"> <li>[0] LED BRIGHTNESS             <ul style="list-style-type: none"> <li>20%-100% (100%)</li> </ul> </li> <li>[1] DSPL CONTRAST             <ul style="list-style-type: none"> <li>30%-100% (70%)</li> </ul> </li> <li>[2] DSPL TIMEOUT             <ul style="list-style-type: none"> <li>OFF</li> <li>1 MIN</li> <li>5 MIN</li> <li>10 MIN</li> <li>20 MIN</li> <li>NEVER</li> </ul> </li> <li>[3] JOG SPEED             <ul style="list-style-type: none"> <li>1-10 (5)</li> </ul> </li> <li>[4] TRIM FRAME             <ul style="list-style-type: none"> <li>01-10 (01)</li> </ul> </li> <li>[5] TRIM SUBFRAME             <ul style="list-style-type: none"> <li>01-25 (01)</li> </ul> </li> <li>[6] PORT SELECT             <ul style="list-style-type: none"> <li>MAC: MIDI, 422:ES</li> <li>MAC: ES, 422:OFF</li> </ul> </li> </ul> <p>[TCG] TCG OPTIONS</p> <ul style="list-style-type: none"> <li>[0] SYSTEM REF             <ul style="list-style-type: none"> <li>INTFIX</li> <li>INTVAR</li> <li>EXTVID</li> <li>AUX</li> <li>VSO MASTER</li> <li>ACG</li> </ul> </li> <li>[1] SYSTEM SPD/CODE             <ul style="list-style-type: none"> <li>24 Hz/24</li> <li>25Hz/25 (PAL)</li> <li>29.97Hz/DF</li> <li>29.97Hz/30 (NTSC)</li> <li>30Hz/DF</li> <li>30Hz/30</li> </ul> </li> <li>[2] VARISPEED %             <ul style="list-style-type: none"> <li>87.5%-112.5% (100.00%)</li> <li>JOG/SHTL WHEEL = ±0.1%</li> <li>[+/-] = ±0.01%</li> </ul> </li> <li>[3] TCG GROUP MODE             <ul style="list-style-type: none"> <li>PLAY, RUN</li> <li>PLAY, MUTE</li> <li>PLAY, WIND</li> </ul> </li> <li>[4] TCG STILL MODE             <ul style="list-style-type: none"> <li>OFF</li> <li>ON</li> </ul> </li> <li>[5] AUX OUTPUT SEL             <ul style="list-style-type: none"> <li>PILOT</li> <li>RESHAPE 1</li> <li>RESHAPE 2</li> <li>RESHAPE 3</li> <li>GPI-2 BEEP</li> </ul> </li> <li>[6] VIDEO SYNC GEN             <ul style="list-style-type: none"> <li>OFF</li> <li>ON</li> </ul> </li> </ul>	<p>[TRKS] TRACK OPTIONS</p> <ul style="list-style-type: none"> <li>[0] VIDEO TRACKS             <ul style="list-style-type: none"> <li>SAFE</li> <li>READY</li> </ul> </li> <li>[1] VIDEO AUTO-RST             <ul style="list-style-type: none"> <li>OFF</li> <li>ON</li> </ul> </li> </ul> <p>[TRAN] MACHINE SELECT</p> <ul style="list-style-type: none"> <li>[LAST/NEXT] TRANSPORT MFG</li> <li>[+/-] MACHINE MODEL</li> </ul> <p>[TRAN] TRAN OPTIONS <sup>2</sup></p> <ul style="list-style-type: none"> <li>[0] CAPSTAN MODE             <ul style="list-style-type: none"> <li>WILD</li> <li>RESOLVED</li> </ul> </li> <li>[1] CAPST SPD TRIM             <ul style="list-style-type: none"> <li>-128 TO +127 (0)</li> </ul> </li> <li>[2] LIFTER DEFEAT             <ul style="list-style-type: none"> <li>NEVER</li> <li>NORMAL</li> <li>NOT STP/PLAY</li> <li>ALWAYS</li> </ul> </li> <li>[3] RECORD IN             <ul style="list-style-type: none"> <li>PULSE REC</li> <li>P-REC,PLAY</li> </ul> </li> <li>[4] RECORD OUT             <ul style="list-style-type: none"> <li>PULSE PLAY</li> <li>P-REC, PLAY</li> <li>PULSE STOP</li> <li>P-REC,STOP</li> <li>P-PLAY,STOP</li> <li>PULSE OPTO</li> <li>SPECIAL OPTO</li> </ul> </li> <li>[5] REHEARSE IN             <ul style="list-style-type: none"> <li>LATCH REH</li> <li>PULSE REH</li> <li>P-REH,PLAY</li> <li>P-REH,RECLOG</li> <li>L-REH,RECLOG</li> <li>PULSE REC</li> </ul> </li> <li>[6] REHEARSE OUT             <ul style="list-style-type: none"> <li>UNLATCH REH</li> <li>PULSE PLAY</li> <li>SAVE AS REC</li> </ul> </li> <li>[7] APPROACH SPEED             <ul style="list-style-type: none"> <li>20-254</li> </ul> </li> <li>[8] BANDWIDTH LIMIT             <ul style="list-style-type: none"> <li>OFF</li> <li>ON</li> </ul> </li> <li>[9] READER MODE             <ul style="list-style-type: none"> <li>LTC/SER TC</li> <li>LTC/TT1</li> <li>SERIAL TC</li> <li>T.TIMER 1</li> </ul> </li> <li>[00] MUTE CONTROL             <ul style="list-style-type: none"> <li>NORMAL</li> <li>UNTIL RSLVED</li> <li>UNTIL LOCKED</li> <li>NOT LOCKED</li> </ul> </li> <li>[NEXT] LOCK THRESHOLD             <ul style="list-style-type: none"> <li>0-50 (35)</li> </ul> </li> <li>[NEXT] LOCK DELAY             <ul style="list-style-type: none"> <li>0-50 (10)</li> </ul> </li> <li>[NEXT] PARK WINDOW             <ul style="list-style-type: none"> <li>0-10 (10)</li> </ul> </li> </ul> <p>[F3] VITC OPTIONS</p> <ul style="list-style-type: none"> <li>[0] GROUP SELECT             <ul style="list-style-type: none"> <li>OFF</li> <li>A</li> <li>B</li> <li>C</li> </ul> </li> <li>[1] READER MODE             <ul style="list-style-type: none"> <li>AUTO</li> <li>FIXED</li> </ul> </li> </ul>
---	--	---	---

NOTE:  
 ALL KEYS ARE IN BRACKETS [ ].  
 FACTORY DEFAULTS ARE ITALICIZED.  
 1 PRESS EVENT KEY THEN DESIRED GPI NUMBER.  
 2 SELECT RDY OR TRAN, THEN MACHINE (A, B, OR C)  
 TO SETUP OPTIONS.  
 3 USE KEYS 0, 1, 2 ONLY AFTER FIRST SELECTION.

**ACG** When the ACG card is installed, it is automatically active. The ACG setup configuration can be adjusted during any Micro Lynx operation without affecting the current operation since the ACG card processor operates independently from the other Micro Lynx functions. The ACG LED will light to indicate that the ACG card is installed. Refer to the Option Card chapter for more detailed information on the Audio Clock Generator.

**SETUP • ACG**

Press [SETUP] then [ACG] to enter the ACG options menu. Use it to set the following operating parameters.

**Table Chapter 8 -3. ACG Setup Menu**

KEY	MENU	SUB-MENU	RANGE
ACG	ACG Option	0 Nom S/Rate Out	32.000, 44.056, 44.100, 47.952, 48.000 Ks/s
		1 Var Ratio Out	Off, On
		2 Var Ratio Out %	85% - 115% (100.00%)
		3 Oversample Out	128, 192, 256, 384
		4 Nom S/Rate In	32.000, 44.056, 44.100, 47.952, 48.000 Ks/s
		5 Var Ratio In	Off, On
		6 Var Ration In %	87.5% - 112.5% (100.00%)
		7 Oversample In	128, 192, 256, 384, Off
		8 Reference In	AES/EBU, Clock In BNC

**F1, F2** The [F1] and [F2] keys are short cut keys to macros (1-2). They are preprogrammed by the factory to capture and store the edit in and out points. It is possible to clear and reprogram these keys; however they will default to the factory settings if the Keyboard Controller is reset. See Macro for more information.

**F3** The [F3] key is used for the VITC reader card.

**Table Chapter 8 -4. F3 Setup Menu**

KEY	MENU	SUB-MENU	RANGE
F3	VITC Options	0 Group Select	Off, A, B, C
		1 Reader Mode	Auto, Fixed

**SYS** The [SYS] key displays the software version numbers for the Micro Lynx system microprocessors and provides access to the system error list.

To display the software version numbers, press [RCL] followed by [SYS]. The version number for each PROM will be displayed. These software numbers are *required* for any communication with the factory.

The SYS LED will flash when a system error occurs. Press [SYS] to enter the "error mode". The SYS LED turns on and the first error message is displayed. Pressing [SYS] again displays the

next error message. After the last error is displayed, all messages are cleared and the Micro Lynx automatically exits the error mode. Pressing [CLR] also exits the error mode. Refer to Troubleshooting for a complete list of error messages.

**CLR + SYS**

Hold the [CLR] key and press the [SYS] key to cold boot or reset the System Unit. This clears all user setup options and returns to the factory defaults. Before this command is executed the following warning message and prompt is displayed:

Press ENTR to confirm.

If you are sure that you want to reset the System Unit, press the [ENTR] key.

**SETUP • SYS**

Press [SETUP] followed by [SYS] to enter the system options menu. There are seven headings in this menu. Use it to set the following system operating parameters:

Table Chapter 8 -5. SYS Setup Menu

KEY	MENU	SUB-MENU	RANGE
SYS	System Options	0 LED Brightness	20% - 100% (100%)
		1 DSPL Contrast	30% - 100% (70%)
		2 DSPL Timeout	Off, 1, 5, 10, 20 min., Never
		3 Jog Speed	1-10 (5)
		4 Trim Frame	01-10 (01)
		5 Trim Subframe	01-25 (01)
		6 Port Select	MAC:MIDI, 422:ES MAC:ES, 422:Off

**TRAN** The [TRAN] key is used to display current machine status.

**TRAN • A (B or C)**

Press [TRAN] followed by a machine select key (A-C). The display shows the selected transport type, the time code frame rate, capstan control, resolved or wild, and whether the time code reader bandwidth limit is selected.

Tran: A AMPEX ATR-124  
TC=30 Resolved BWL Off

### CLR + TRAN

The [TRAN] key is also used with the [CLR] key to reset a machine select key to factory default settings. Solo a transport then press and hold the [CLR] key and press [TRAN], the following message is displayed as the transport parameters are reset:



Transport Clearing Now

### SETUP • TRAN

Press [SETUP] followed by [TRAN] to enter the TRAN options menu. This menu has two pages. Press the [TRAN] key again to access the second page.

The first page has a list of all the machines that the Micro Lynx supports. Use the [LAST] and [NEXT] keys to select the tape machine manufacturer. Press the [+] and [-] keys to step through the list of transports for that manufacturer. This process should be repeated for each machine connected to the system. Press machine select key (A-C) to select the next machine and set the appropriate transport type.

Press [SETUP] again to exit setup and store the transport settings. The transport selections are retained in memory and should only need to be reset if the transport type is changed.

The second transport setup page contains a list of transport specific parameters. Most of the 10 menu settings are automatically set by the selected transport type. Select a specific heading and use the [+] and [-] keys to make changes to the default settings, if required.

Table Chapter 8 -6. TRAN Setup Menu

KEY	MENU	SUB-MENU	RANGE	
TRAN	Machine Select			
	Last/Next	Transport Mfgr		
	+/-	Machine Model		
	TRAN	0 Capstan Mode		Wild, Resolved
		1 Capst Spd Trim		-128 to +127 (0)
		2 Lifter Defeat		Never, Normal, Not Stp/Play, Always
		3 Record In		Pulse Rec; P-Rec, Play
		4 Record Out		Pulse Play; P-Rec, Play; Pulse Stop; P-Rec, Stop; P-Play, Stop; Pulse Opto; Special Opto
		5 Rehearse In		Latch Reh; Pulse Reh; P-Reh, Play; P-Reh, Reclog; L-Reh, Reclog; Pulse Rec
		6 Rehearse Out		Unlatch Reh, Pulse Play, Save as Rec
		7 Approach Speed		20-254
		8 Bandwidth Limit		Off, On
		9 Reader Mode		LTC/SER TC; LTC/TT1; Serial TC; T.Timer 1
		00 Mute Control		Normal, Until Rslved, Until Locked, Not Locked
		NEXT Lock Threshold		0-50 (35)
NEXT Lock Delay		0-50 (10)		
NEXT Park Window		0-10 (10)		

The transport option menu parameters operate as follows:

**Capstan Mode Resolved.** The Micro Lynx controls the speed of the machines capstan. It is used when synchronizing.

**Capstan Mode Wild.** The machine capstan is set to its own internal reference and the Micro Lynx does not control its speed. Use it when striping time code or if the tape has no time code.

**Capstan Speed Trim.** This advanced feature should be used only by an experienced engineer or technician. It allows the “wild speed” of the machine to be adjusted by the operator when a voltage controlled machine does not run at the right speed before synchronizing. It also adjusts the wild speed for a tape that was recorded off pitch.

This adjustment is retained in memory, separately for each transport type. It is restored when the transport is selected. It is NOT erased when [CLR] + [TRAN] is pressed. It is only erased if a complete memory clear is performed, [CLR] + [SYS]. This allows

the information to be retained for a machine when selecting another machine.

**Lifter Defeat.** Selects which condition allows the Micro Lynx to defeat the machines lifters to read time code from the tape; it is usually set to Normal. In Normal, the Micro Lynx defeats the lifters only as the machine slows to park, to check that it has located correctly.

**Record In.** Selects the command method or logic to punch the machine into record.

**Record Out.** Selects the command method or logic to punch the machine out of record.

**Rehearse In.** Selects the command method or logic to punch the machine into rehearse.

**Rehearse Out.** Selects the command method or logic to punch the machine out of rehearse.

**Approach Speed.** Sets the approach speed or deceleration point for a machine as it slows to park. Use it to adjust machine performance if the park point is consistently over or under shot. Increase the value to slow the transport later. Decrease the value to slow the transport earlier.

**Bandwidth Limit.** Selects a time code reader input (RDR) filter circuit that bandwidth limits the input frequency range. This should be used if the time code source is noisy. This is usually only required with video machines.

**Reader Mode.** Selects the time code source for the machine; it is normally set to LTC. Serially controlled video machines will be set to read serial time code as follows:

- **Serial TC:** The Micro Lynx asks the transport for either longitudinal or VITC time code. Arbitration between the two is performed by the transport itself. Synchronization is achieved using serial time code only, and the local longitudinal reader is completely disabled. All numeric information in the time display is collected over the serial port.

It is essential, if serial time code lock is to be used, that both the Micro Lynx and the serial transport are referenced to the same video reference source, as time code requests to the transport must synchronize to this reference.

This selection will revert internally to "LTC/SerTC" if the selected transport is not capable of serial time code locking.

- **Serial TT1:** The Micro Lynx requests only tape timer information from the serial transport. Synchronization is

performed using control track data alone, without the assistance of a time code track. The tape timer time code defines tape position absolutely, and may be reset or preset from the keyboard. When in this mode, all operations are performed exactly as if actual time code were present.

Notes:

- a) The new time code selections apply to transports using Sony protocols only. For Ampex transports, no distinction is made between LTC/VITC, LTC and VITC.
- b) The default serial time code selection for any transport is loaded when the transport is selected. It is no longer reset by a CLR TRAN.

**Lock Threshold.** The time code window or threshold in subframes (0-50 sfr) that the machine has to be within before the lock delay starts running. The lock window setting can be adjusted when time-to-lock may be more critical than lock accuracy. This can be used to fix problems with unstable machines, bad or misframed time code or to cause a Digital or Video tape transport to release with a looser lock tolerance. The setting is used in conjunction with the Lock Delay setting.

**Lock Delay.** The time in frames (0-50 fr) that the machine has to be continuously in the lock window, before it is considered that the transport is locked, and the Micro Lynx will show lock status. It should be noted that very short lock delays could result in the machine locking in the wrong place.

**Park Window.** The park window in frames (0-10 fr), for video and film transports only. This is used to accurately cue a video transport to a specific location. If the park window is set to zero, then the transport will respond to a  $\pm 1$  frame locate. The video park window setting is set for all VTRs and is not reset when a different video machine is selected for that group (A-C).

**EVNT** The [EVNT] key is used to access the Micro Lynx GPI relays. The GPI relays can be made to operate or follow several internal time code registers. The default setting for the GPIs is Auto-set. In this mode, the relays follow the edit in point. When the in point is changed, then the GPI execution point changes with it.

If a GPI closure is required at a particular time code value then set the GPI mode to Normal and enter a GPI in point time code value. The GPI will then always operate at that time code value.

Each GPI has a Preroll and Duration register. The Preroll register is used to advance the closure time to allow for slow start of externally triggered devices. The Duration can be set to suit the

closure type required. Press [EVNT] followed by a 1 or 2 to select the respective GPI.

The following transport keys are used to affect GPI operation:

**STOP.** Takes the GPI offline

**PLAY.** Sets the GPI to ready or active

**REH.** Will rehearse the closure

**SETUP • EVNT**

Press [SETUP] followed by [EVNT] to enter the EVNT Setup option. Select the GPI number to enter the menu. GPI 1 only has a mode select option. GPI 2 has four headings that define the event process. GPI 2 can be set to operate as a dialog beep or talent cue output, by setting options 1-3.

**Table Chapter 8 -7. EVENT Setup Menu**

KEY	MENU	SUB-MENU	RANGE	
EVENT	Select GPI Options			
	1 GPI 1		Normal, <i>AutoSet</i> , Rec Tally, Edit Rec, Reh Tally, Edit Reh, Lock Tally	
	2 GPI 2	0 Mode		<i>Normal</i> , Autoset, Rec Tally, Edit Rec, Reh Tally, Edit Reh, Lock Tally
		1 Beep Mode		Off, <i>On</i>
		2 Beep Spacing		10-30 ( <i>20</i> )
3 Last Beep			<i>Muted</i> , On	

**LIST** This function is not currently in use. It will be used in the future for access to list functions.

**MEM** The [MEM] or Memory register key is used with the calculator keypad. Use [STO] to store time code numbers to a memory register and [RCL] or [MEM] to recall numbers from a memory register.

Up to 100 memory registers are available in the Micro Lynx. The default is 0-9. Use the Setup menu to select 00-99 memory locations. If you select 100 registers, you must always enter two digits to store or recall a number. To recall a memory, press the [MEM] key followed by the memory register number. The memory time code value is displayed. To store a time code number, press [STO] followed by [MEM] and the memory register number.

SETUP • MEM

Press [SETUP] followed by [MEM] to change the memory size. Memory size selects the number of memory spaces that will be available for storing values.

Table Chapter 8 -8. MEM Setup Menu

KEY	MENU	SUB-MENU	RANGE
MEM	Memory Option	Memory Size	0-9, 00-99

## Group Select Keys

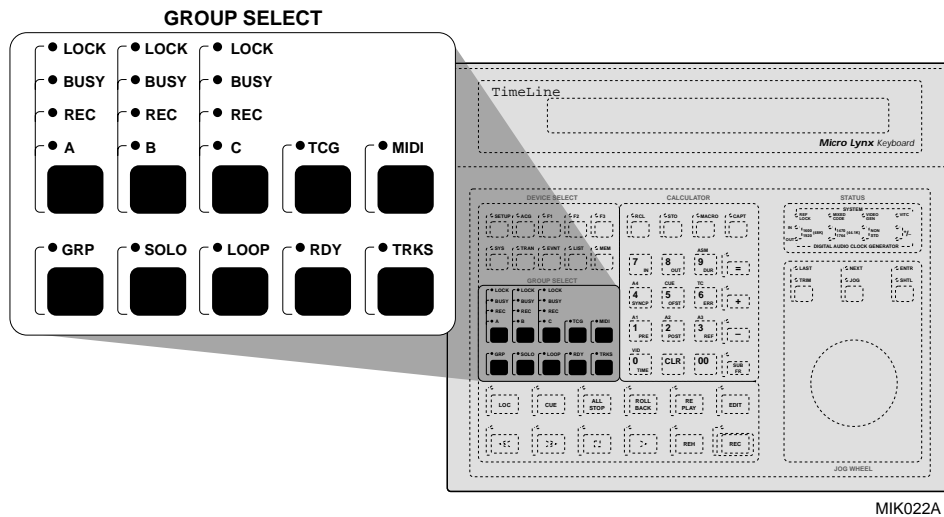

Figure Chapter 8 -7. Group Select Keys

### A-C, TCG, MIDI

The Micro Lynx will control up to three machines that are assigned to the Group keys (A-C). The C machine is only available when a Machine Expansion Card (M3) is installed. The Time Code Generator (TCG) also has a “machine” key and can be considered as a 4th machine. The [TCG] key controls both the LTC and MTC generators. The three machines and the TCG may be operated either individually in solo mode or together, synchronously in group mode.

### Solo Mode

Press [SOLO] and the appropriate machine select key (A-C, TCG). The transport control keys will control only the selected machine. All other machines will remain in their current state of motion. To select a different machine, press the appropriate machine select key (A-C, TCG). Solo TCG is normally only used if you want to generate time code, but can be used to control a time code only chase device.

### Group Mode

All machines assigned to the group will be controlled together by the transport control keys (synchronously in play). To assign a machine to the group, press and hold the [GRP] key and press the appropriate machine select key (A-C, TCG). To remove a machine

from a group, press and hold the [GRP] key and the appropriate machine select key (A-C, TCG). The [MIDI] key is a special case that is used for MIDI time code chase. When the [MIDI] key is grouped, it automatically becomes the Master.

#### **SETUP + A-C, TCG**

Use this key combination to change the master machine designation. Press and hold the [SETUP] key, then press the key (A-C or TCG) of the machine that you want to select as master.

#### **LOCK LED**

This LED indicates that the corresponding machine (A-C) is in play and locked to the system reference.

#### **BUSY LED**

This LED indicates that the corresponding transport is in motion but not locked. Generally, one of the following operations is in progress:

- Start of Play
- Rewind
- Fast Forward
- Shuttle/Jog

If this LED is always turned on, then the corresponding machine (A-C) is in wild speed mode. In wild speed mode the Micro Lynx is not controlling the machine's capstan and the machine is not locked to the system reference. It is used to stripe a new reel of time code or if a tape has no time code. See Getting Started for an example of striping time code.

#### **REC LED**

This LED indicates that the corresponding machine is in Record. If it is flashing then the machine is record enabled; it will go into record when a REC command is issued.

#### **TCG**

The [TCG] key selects or deselects the Time Code Generator (TCG). The TCG can be soloed or included in a group like a tape machine. Use the TCG options menu in Setup mode to select the time code type and generation method. The generator will always jam to the incoming reader code and can be set to either run continuously or follow group transport operation. If necessary, an offset can be entered.

The TCG LED indicates that SMPTE time code is being generated or will be generated when the play command is issued. Time code generation is selected in Setup mode under TCG options. When striping time code for the first time, use the preprogrammed macros, which automatically set up the Micro Lynx to generate time code (MACRO + 9) and macro (MACRO + 8) to exit time code generation mode. An example is presented in the Getting Started section.

**SETUP • TCG**

Press [SETUP] followed by [TCG] to enter the TCG options menu. This menu has seven headings that set the system reference, time code types, generator mode, aux output signal, and the video sync generator. Pressing a calculator key (0-6) gives direct access to the various menu headings. Use the TCG options to configure the Micro Lynx system for your particular application. The selections are as follows.

**Table Chapter 8 -9. TCG Setup Menu**

KEY	MENU	SUB-MENU	RANGE
TCG	TCG Options	0 System Ref	<i>Intfix</i> , <i>Intvar</i> , <i>Extvid</i> , <i>Aux</i> , <i>VSO Master</i> , <i>ACG</i>
		1 System Spd/Code	24Hz/24; 25Hz/25 ( <i>PAL</i> ); 29.97Hz/DF; 29.97Hz/30 ( <i>NTSC</i> ); 30Hz/DF; 30Hz/30
		2 Varispeed %	87.5% - 112.5% ( <i>100.00%</i> ) Jog/Shtl Wheel = $\pm 0.1\%$ +/- = $\pm 0.1\%$
		3 TCG Group Mode	Play, Run; <i>Play</i> , <i>Mute</i> ; Play, Wind
		4 TCG Still Mode	Off, On
		5 Aux Output Sel	Pilot, Reshape 1, Reshape 2, Reshape 3, <i>GPI-2 Beep</i>
		6 Video Sync Gen	Off, On

**MIDI**

The Micro Lynx generates MIDI Time Code (MTC) locked to the system reference with the same time code value as the SMPTE time code generator. When the TCG LED is on, it indicates that MTC is being generated or will be generated when a play command is issued. The MIDI Time Code generator is automatically selected with the time code generator.

When MIDI is selected as a machine, the MTC source automatically becomes the group master. This is a special synchronization case that is only used when it is required to operate the system in MIDI time code chase.

## SETUP + MIDI

The Micro Lynx provides a comprehensive MIDI routing capability. Please refer to the Advanced Features section for detailed information.

## GRP (GROUP)

Press [GRP] to operate selected tape machines as a synchronous group. When group is active, the GRP LED and the selected machine keys (A-C, TCG) will turn on. See the Getting Started section for a complete example.

### Procedure

#### *To assign a tape machine to a Group:*

1. [GRP]

*GRP and machine LEDs flash*

Hold the "GRP" key, and add groups in order of priority.
--

This is the machine selection prompt. You have not grouped any machines.

2. [GRP] + [A]

*A LED turns on*

A*	A→ 1:03:47:17
.	0

Press [GRP], hold it, and press the Machine select key. Time code and machine letters are displayed, the A machine is the master.

#### *Remove a machine from the Group:*

3. [GRP] + [A]

Hold the "GRP" key, and add groups in order of priority.
--

Press [GRP] and the machine select key to remove a machine from the group.

**GRP Status Mode** The machine keys (A-C, TCG) are used to access status mode. Status mode displays information specific to the machine selected. Status mode is indicated on the display as follows:

STAT:A	A→23:59:32:22
.	Err: 0.-

The time code and offset error for the selected machine is displayed. The group LEDs stay lit in both GRP and STAT modes.

To display machine status perform the following:

**Procedure**

1. [GRP]

```

A* b t           A-> 1:03:47:17
. . .           0
    
```

2. [B]

```

STAT:b           b-> 1:03:47:17
. . .           Err: 0.-
    
```

Select the appropriate machine key. Status information for B is displayed.

3. [B]

```

A* b t           A-> 1:03:47:17
. . .           0.-
    
```

Exit status mode by pressing the machine key or [GRP].

**SETUP • GRP**

Press [SETUP] followed by [GRP] to enter group options in the setup menu. There are four headings:

**Table Chapter 8 -10. GRP Setup Menu**

KEY	MENU	SUB-MENU	RANGE
GRP	Group Options	0 Search Mode	Chase, <i>Group</i>
		1 Ref Follow Mstr	Off, <i>On</i>
		2 Group parkahead	0-30 (25)
		3 GRP LED Status	<i>Normal</i> , Time code

**Group Search Mode** If Group search is selected the machines will locate independently. If Chase search is selected they will chase the master machine. Whether you select chase or group depends on the machines selected and your normal method of working. If a lot of manual locating will be performed, then the system time to lock may be improved by selecting chase search.

**REF Follow MSTR** When Reference follow Master is set to on, then each time the Master machine is changed, the reference transport will change with it.

**Group Park Ahead** The default time in frames (0-30) that the slave transports will park ahead of the Master in stop. This value is modified by the system to optimize lock time, unless set to zero when the machine will always park at the Master position.

**Group LED Status** The GRP LEDs can be set to indicate

- Normal status, the machines selected to the group.
- Time code present.

In normal status the GRP LEDs (A-C, TCG) will be on if a machine is selected to the group.

In time code status, the GRP LEDs turn on when a machine is in play and time code is present. The LEDs turn off in stop and if a machine is in play with no time code present.

If time code present status is selected, when the [GRP] key is pressed, the LEDs will switch to normal status and turn on to indicate those machines selected to the group.

### GRP + SETUP

Press and hold the [GRP] key, then press the [Setup] key to clear all machines in the group and select a new reference machine. The first machine selected becomes the new time code reference machine. All positional information is retained and any offset information is correctly transferred to the new slave machines. Remember: The time code reference machine (\*) does not have to be the master machine. (See Setup + A-C to select a new master machine).

### Procedure

1. [GRP]

A*	b	t	A→ 1:03:47:17
.	.	.	0

A is the reference machine.

2. [GRP] + [SETUP]

Hold the "GRP" key and add groups in order of priority.			
---	--	--	--

Reselect the group. The first machine selected will be the reference machine.

3. [GRP] + [B]  
[GRP] + [A]

a	B	B→ 1:03:47:17
.	.	0

B becomes the reference and master. Offsets are automatically transferred.

4. [A] + [SETUP]

A	b*	B→ 1:03:47:17
.	.	0

A becomes the master, B remains the reference. Offsets are transferred.

## SOLO

Press [SOLO] and the appropriate machine select key (A-C, TCG) to place a machine in Solo mode. The transport motion control keys will only control the soloed machine, all other machines remain in their previous state. Press the [SOLO] key a second time to switch back to GRP mode.

**Status Mode** The machine keys (A-C, TCG) are used to access Status mode in Solo. Press the soloed machine key; the display will show the offset error for the soloed machine. Press [SOLO] or the machine key again to return to Solo mode.

### Procedure

1. [SOLO] + [A]

SOLO:A	A→ 1:03:47:17
	0

A is soloed.

2. [A]

SOLO:A .	A→ 1:03:47:17
	Err: 0.-

The offset error status is displayed.

3. [A]

SOLO:A	A→ 1:03:47:17
	0.-

Press the machine key or [SOLO] to take A out of status mode

## LOOP

Press the [LOOP] key to select Edit Loop or Cycle mode. The Loop key will continuously cycle an edit until it is interrupted by a transport command.

### SETUP • LOOP

Press [SETUP] followed by [LOOP] to select the loop options. This menu has three headings that define the loop process after edit and replay passes. Press a calculator key (0-2) for direct access to the menu headings.

Table Chapter 8 -11. LOOP Setup Menu

KEY	MENU	SUB-MENU	RANGE
LOOP	LOOP Options	0 After Edit	Re-Edit, Replay
		1 After Replay	End, Repeat
		2 After End	Stop, Recue

## RDY

The [RDY] key is used to record enable tape machines. Press and hold the [RDY] key followed by a machine select key (A-C) to record enable a specific machine. When the machines REC LED flashes, it is record enabled. When a transport record command is issued, machines that are in play and locked will enter record and the REC LED stops flashing and turns on.

To disable record enable status for an individual machine, press and hold the [RDY] key; then press the machine select key again.

To disable all machines that are record enabled, press and hold [CLR] followed by [RDY].

### SETUP • RDY

Press [SETUP] followed by [RDY] to enter the record timing options menu.

**Table Chapter 8 -12. RDY Setup Menu**

KEY	MENU	SUB-MENU	RANGE
RDY	Record Options	0 Rec Adv 30-In	0-255
		1 Rec Adv 30-Out	0-255
		2 Rec Adv 15-In	0-255
		3 Rec Adv 15-Out	0-255
		4 Rec Adv 7.5-In	0-255
		5 Rec Adv 7.5-Out	0-255

The record command advance timing is automatically set for each transport when it is selected. If necessary, use this menu to further advance or retard the record command at each tape speed for a particular machine.

## TRKS

Use the [TRKS] key to record enable specific tracks on a tape or video machine. This feature is normally only fully used on serially controlled machines. Press the [TRKS] key to enter track select mode. Press the machine select key (A-C) that you wish to record enable.

When a track is enabled the track number is displayed; if the track is safe, a line (-) is displayed. XXX indicates that the track is safe or unavailable. To accommodate the various types of machines, one of three different setup displays will be used.

**Procedure**

1.

TRAN A:	A1	A2	A3	A4	Syn	TC
TRACKS						

Video or audio machine with less than 5 audio channels.

2.

TRAN A:	A1	A2	A3	A4	A6	A7	A8
TRACKS							

Machines up to 8 audio channels.

3.

TRAN A:	01	-	-	-	-	-	-	-	-	-	-	-	-	-	-	-	-	-	-	23
TRK #5	02	-	-	-	-	-	-	-	-	-	-	-	-	-	-	-	-	-	-	24

Multitrack with more than 8 audio channels.

To disable (or safe) all record enabled tracks, hold [CLR] then press [TRKS].

**Video Machines** Press the following calculator keys to record enable the corresponding track.

Key	Track	Key	Track
1	A1	0	Vid
2	A2	5	Sync/Cue
3	A3	6	Time code
4	A4	9	Assemble

**Audio Machines** For multitrack machines with up to 8 tracks, press the following calculator keys to record enable the corresponding track.

Key	Track	Key	Track
1	A1	5	A5
2	A2	6	A6
3	A3	7	A7
4	A4	8	A8

**Multitrack Machines** Enter the track number and use the [LAST] and [NEXT] keys or the Jog Wheel to select the track to be record enabled. Press [+] to enable and [-] or [CLR] to disable (or safe) each track. If the machine has more than 24 tracks, press the [TRKS] key a second time to display the higher number tracks.

Key	Function
(Number)	The number toggles the track
CLR	The selected track is cleared
CLR + TRKS	Clears all of the tracks
+/-	Toggles the track
Jog Wheel	Selects the track number

**Procedure**

A* B t	B→ 1:09:55:07
. . .	0

1. [TRKS]

*TRKS LED flashes*  
*Selected TRAN LEDs flash*

TRAN B:	- - - - -
TRK #	- - - - -

The selected machine and TRAN LEDs flash. Change machine by pressing a different machine select key.

2. [01], [02], [03], [04]

TRAN B:	1 3
TRK #4	2 4

Press [NEXT], use the Jog Wheel, or enter the track number (number less than 10 must be preceded by a zero).

Track is safe or not available
--------------------------------

If this message is displayed, the track is not available or must be enabled.

3. [+] and [-]

TRAN B:	1 3 5
TRK #5	2 4

Press [+] (plus) to enable tracks. Press [-] (minus) to disable (safe) tracks.

4. [CLR] + [TRKS]

TRAN B:	- - - - -
TRK #5	- - - - -

Press [CLR] + [TRKS] to make all tracks safe.

5. [TRKS]

A* B t	B→ 1:09:55:07
. . .	0

Press [TRKS] or a motion key to return to normal operation.

**SETUP • TRKS**

Press [SETUP] followed by [TRKS] to enter the Tracks option menu. The two selections in this menu relate specifically to video machines.

**Table Chapter 8 -13. TRKS Setup Menu**

KEY	MENU	SUB-MENU	RANGE
TRKS	Track Options	0 Video Tracks	Safe, Ready
		1 Video Auto-Rst	Off, On

**Video Tracks** Ready allows access to the video insert track enable and assemble mode for video machines. This option defaults to safe and is inhibited in track select.

**Video Auto Reset** Video Auto Reset, works in conjunction with setup menu option 0, Video tracks. If Video auto-reset is set on and Video tracks is set to ready, access is permitted to the video tracks for a single record pass. The Micro Lynx allows one record command to be issued to the video machine and then automatically resets the video tracks option back to safe.

These two options are designed to protect the audio facility from inadvertently recording on the video portion of a work tape. However, in some circumstances video track enable may be necessary. For example, when a transfer is being done from one machine to another.

## Calculator Keys

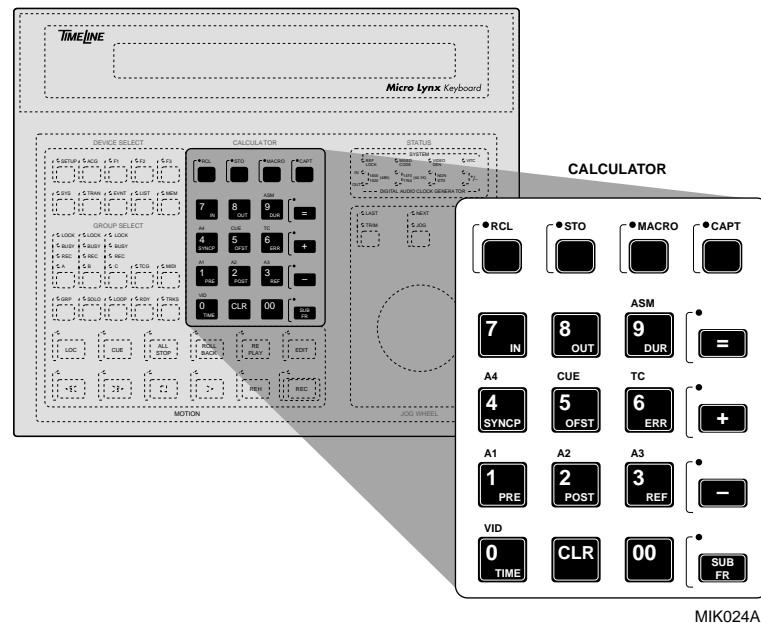

Figure Chapter 8 -8. Calculator Keys

The Micro Lynx Calculator keys perform multiple functions:

- Number Keypad
- Register & Memory Locations
- Auxiliary Function

When a numbered key is pressed, the calculator is active. Calculator numbers are entered left-to-right with the most significant digit first, leading zeros are ignored. Auxiliary function keys [+], [-], and [=] are used with the calculator.

When a numbered key is pressed after [TRIM], [CAPT], [RCL], or [STO], the auxiliary function of the numbered key becomes active.

**00**

This key is similar to the double 0 key on a calculator; it inserts two zeros into the display. This is particularly useful when entering time code numbers.

**CLR**

This is a multiple mode Clear key. It clears the data entry area of the display window.

Press [CLR] to perform the following:

1. Exit calculator mode and return to the normal operating display.
2. Clear incorrect entries for any key or function.
3. Clear the data entry buffer. If a number is entered but not yet stored to a register, the original register value is retained.
4. Clear registers. To clear a specific register, simultaneously press the [CLR] key and the calculator key for the register that you wish to clear. For example, hold down the [CLR] key and press [OFST] to clear the offset register for a slave machine.
5. The [CLR] key is also used in combination with the “Device Select” and “Group Select” keys to cancel or reset system parameters.

**Procedure**

**CLR**

1. 1 2 3



The numbers entered are displayed in the calculator display, the lower right quadrant of the display.

2. [CLR]



The calculator display is cleared. It will be cleared during any arithmetic operation also.

**Clear a Register**

3. [RCL]



Press [MEM] or a register number.

4. [5] (OFST)

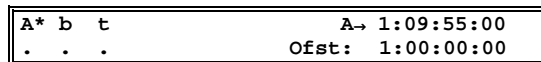

The register or memory contents are displayed.

5. [CLR] + [5]



The register display is cleared.

**CLR + SYS**

6. [CLR] + [SYS]

Press ENTR to confirm

Since this key combination resets the System Unit to its default condition, you are asked to confirm this action.

[ENTR] (SHTL)

System Unit Clearing Now

Press any other key to abort the reset.

**CLR + SETUP**

7. [CLR] + [SETUP]

Press ENTR to confirm

Since this key combination resets the Keyboard Controller to its default condition, you are asked to confirm this action.

[ENTR] (SHTL)

"Holding memory" unless you press and  
hold CLR key within 1 second

Lamp test, Holding Memory

The Keyboard resets. All memory settings are retained.

8. [CLR]

Lamp test, Clearing Memory

If the [CLR] key is held within 1 second of pressing [ENTR], the Keyboard resets and clears memory settings.

**CLR + TRAN**

9. [SOLO] + [A]

SOLO:A > A→ 1:00:00:00  
0

Select solo mode. Select the machine to reset.

10. [CLR] + [TRAN]

Transport Clearing Now

The selected machine is reset to factory default parameters.

**Remember:** it is not necessary to reselect the transport.

**0 TIME/VID**

**TIME** When not used as a 0 in calculator mode, the [TIME] key provides

access to the Time register. Press [RCL] or [STO], then [TIME] to recall the current value or store a new value in the Time register. The current time code of the machine selected will be displayed. To display the current time code of a different machine: press the appropriate machine select key followed by [RCL] then [TIME].

**VID** Press this key in TRKS mode to select and deselect the video insert track record enable on a video machine.

## 1 PRE/A1

**PRE** When not used as a 1 in calculator mode, the [PRE] key provides access to the Preroll register. This register may be accessed during store, recall, and trim operations. The value in the preroll register is used to calculate the preroll position.

$$\text{Preroll position} = \text{In Point} - \text{Preroll value}$$

The preroll position is the time code location that the Micro Lynx uses to cue the master machine during locate and edit functions. The default value for preroll is five seconds.

**A1** Press this key in TRKS mode to select and deselect the A1 track record enable.

## 2 POST/A2

**POST** When not used as a 2 in calculator mode, the [POST] key provides access to the postroll register. This register may be accessed during store, recall, and trim operations. The value in the postroll register is used by the Micro Lynx to calculate the postroll time code position at the end of an edit sequence. The postroll position is the time code location that the Micro Lynx will roll the transports to at the end of an edit. The default value for postroll is five seconds.

$$\text{Postroll position} = \text{Out Point} + \text{Postroll value}$$

**A2** Press this key in TRKS mode to select and deselect the A2 track record enable.

### 3 REF/A3

**REF** When not used as a 3 in calculator mode, the [REF] key provides access to the Reference Sync Point register. This register may be accessed during store, recall, and trim operations. Press [CLR] and [REF] simultaneously to clear the reference sync point register. The time code number in the reference sync point register is used by the Micro Lynx to automatically calculate offsets for any source machines with source sync points entered. The offsets are calculated as follows:

$$\text{Offset} = \text{Source Sync Point} - \text{Reference Sync Point}$$

If you change the reference sync point value, in Trim mode or enter a new reference sync point value, the Micro Lynx automatically recalculates and stores the correct offset for all source machines with active source sync point values.

**A3** Press this key in TRKS mode to select and deselect the A3 track record enable.

### 4 SYNCP/A4

**SYNCP** When not used as a 4 in calculator mode, the [SYNCP] key provides access to the Source Sync Point register for a specified machine. This register may be accessed in store, recall, and trim operations. Each source machine in the system has a separate sync point register.

To clear the source machine's sync point register, solo a slave machine then simultaneously press [CLR] and [SYNCP].

The time code value in each machine's source sync point register is used by the Micro Lynx to automatically calculate an offset for a source machine relative to the reference sync point. The offset is calculated as follows:

$$\text{Offset} = \text{Source Sync Point} - \text{Reference Sync Point}$$

The result of this calculation is displayed as a positive or negative number with an absolute value of 12:00:00:00 (12 hours) or less.

If the reference sync point has a higher time code number than the source sync point, the keyboard displays the offset as a small negative number (for example: -1:10:00:00 rather than the equivalent large positive number, which would be 22:50:00:00).

If you change a source sync point value in trim mode or enter a new source sync point value, the Micro Lynx automatically recalculates the offset for that machine.

The reference machine can not have a source sync point register.

- A4** Press this key in TRKS mode to select and deselect the A4 track record enable.

**Procedure**

**Set a Sync Point**

1. [SOLO] + [B]

SOLO:b .	b→ 2:09:55:00
	0

Solo a slave machine.

2. [CAPT]

*STO LED flashes.*

Store reg or mem	b→ 2:09:55:00
	2:09:55:00

Enter or capture a time code value and select a register to store the value.

3. [4] (SYNCP)

SOLO:b .	b→ 2:09:55:00
	Sync: 2:09:55:00

The value is stored in the register. A new offset is automatically calculated and stored for the slave machine, if a ref sync point exists.

**Clear a Sync Point**

4. [SOLO] + [B]

SOLO:b .	b→ 2:09:55:00
	0

5. [CLR] + [4]

SOLO:b .	b→ 2:09:55:00
	0

The value in the sync point register is cleared.

6. [RCL] + [4]

SOLO:b .	b→ 2:09:55:00
	Sync: 0

You can verify the clear by recalling the sync point register contents.

## 5 OFST/CUE

**OFST** When not used as a 5 in calculator mode, the [OFST] key provides access to the Offset register for a specified machine. This register may be accessed during store, recall, and trim operations. Each slave machine in the system has a separate offset register. The reference machine can not have an offset.

The offset is a numerical expression of the relationship between the source and reference machine time code positions. It is always applied to a slave machine. Offset is determined:

$$\begin{array}{rcl} \text{Slave/Source time code} & - & \text{Master/Reference time code} & = & \text{Offset} \\ 02:00:00:00 & - & 03:00:00:00 & = & -1:00:00:00 \end{array}$$

A positive offset indicates that the source machine time code position is in advance of the reference machine time code position. If the machine selected is the reference tape machine, then the offset register value will be zero since offsets are always applied to slave machines.

Select a machine in solo or group status mode and press [RCL] or [STO] to recall the current offset value or to store a new value in the offset register. If an offset is required, there are three ways to calculate the value: by sync points, manually, or by capturing the offset.

### Procedure

1. [SOLO] + [B]

SOLO:b .	b→ 2:09:55:00
	0

Solo a slave machine.

2. [RCL] + [5]

*RCL LED flashes*

SOLO:b .	b→ 2:09:55:00
	Ofst: 3:01

Recall the contents of the offset register.

3. [TRIM] + [+]

*TRIM LED flashes*

SOLO:b .	b→ 2:09:55:00
Trim by 1	Ofst: 3:02

Turn the Jog Wheel or press [+] or [-] to change the offset value

4. [TRIM]

TRIM LED off



Exit trim mode, the new offset is automatically saved.

The Micro Lynx handles offsets correctly in either drop frame or non-drop frame time code as well as in mixed time code situations. Offsets are always stored and displayed in the code format of the reference transport's time code, regardless of the type of code that is present on each source machine. For example, if the reference time code is drop frame, all offsets are handled and displayed by the Micro Lynx as drop frame time code values, even if a particular offset is related to a machine with non-drop frame code.

**Remember,** drop frame code is displayed on the keyboard with the frames digits separated from the seconds digits by a comma rather than a colon:

03:20:40,00

In mixed code situations, the actual offset value necessary to achieve the desired synchronization in the Micro Lynx system is the sum of three components:

1. The actual, "clock" difference between the two time code numbers.
2. A correction to this "clock" offset based on the difference in frame counts between the two time code formats.
3. A correction for the accumulated frame count difference since 00:00:00:00 (time code 'midnight').

For example, if you want to synchronize 1:00:00:00 (non-drop frame) with 1:00:00,00 (drop frame), it actually requires an offset of 3 seconds and 18 frames to account for the difference in running frame count since 'midnight'.

As shown by the complexity of this drop frame example, the simplest method of calculating offsets is to use sync points or capture the frame count and let the Micro Lynx calculate the correct time code offset value.

**CUE** Press this key in TRKS mode to select or deselect the [CUE] track record enable on a video machine.

## 6 ERR/TC

**ERR** When not used as a 6 in calculator mode, the [ERR] key provides access to the machine offset Error register. The error register does not store any numbers, it provides a display of the positional error of a machine. Press [RCL] then [ERR] to display the error register for a selected machine. The error is automatically displayed in status mode.

**TC** Press this key in TRKS mode to select and deselect the time code track record enable for a video transport.

**Status Mode** When the Micro Lynx is in group mode, pressing the machine key (A-C, TCG) selects Status mode and automatically recalls the error register. The error register contains the error between the master and slave tape position in frames (see the [GRP] key description under Function Select keys for more information).

The error register display is programmed to show the most relevant information at all times. There are occasions when the offset error display has no meaning. The following table shows the error register status in each transport mode.

**Table Chapter 8 -14. Error Register**

Display Mode	STOP	PLAY	Rewind/FWD
Solo	0.--	Resolve error (in subframes)	0.--
Group	0.--	Resolve error (Mast machine)	0.--
Stat slave	Distance from Mast (park-ahead)	Resolve error (in subframes)	Distance from Mast (Offset err)
Stat master	0.--	Resolve error (Mast machine)	0.--

The Micro Lynx automatically displays subframe error when the error is less than 1 frame.

For example:

STAT:b .	b→ 2:09:55:00
	Err: 0.01

When the displayed error is greater than 1 frame, the sub-frame component is suppressed and shows only as "x.--."

STAT:b .	b→ 2:09:55:00
	Err: 23.-

## 7 IN

When not used as a 7 in calculator mode, the [IN] key provides access to the In Point register. The in point register may be accessed in store, recall, and trim operations. Press [CLR] and [IN] simultaneously to clear the in point register. The number in the in point register is the record in point time code value of the currently programmed edit; it is expressed in terms of the master machine's time code. If there is no in point set then it will be automatically calculated when you enter an out point and a duration.

$$\text{In Point} = \text{Out Point} - \text{Duration}$$

The edit-in point is used to calculate source machine offsets if no reference sync point is entered.

## 8 OUT

When not used as an 8 in calculator mode, the [OUT] key provides access to the Out Point register. This register may be accessed during store, recall, and trim operations. Press [CLR] and [OUT] simultaneously to clear the out point register. The number stored in the out point register is the record out point of the currently programmed edit; it is expressed in terms of the master machine's time code.

The out point is automatically calculated and stored when you enter an in point and a duration.

$$\text{Out Point} = \text{In Point} + \text{Duration}$$

Altering the value of the duration will also cause the out point to be recalculated. Conversely altering the out point automatically recalculates the duration.

## 9 DUR/ASM

**DUR** When not used as a 9 in calculator mode, the [DUR] key provides access to the Duration register. This register may be accessed in store, recall, and trim operations. Whenever there are active values in the in- and out-point registers, there is a calculated time code value in the duration register. Press [CLR] and [DUR] simultaneously to clear the duration register. Clearing the duration register automatically cancels the out point register. The number in the duration register is the length of the current programmed edit.

$$\text{Duration} = \text{Out Point} - \text{In Point}$$

If either the in point or out point are changed, the duration is automatically recalculated.

**ASM** Press this key in TRKS mode to select or deselect the Assemble function for a video machine.

**Procedure**

**Enter In Point**

- [1], [2], [3], [00], [00]

A* b t	A→ 1:09:55:00
. . .	1:23:00:00

Use the calculator keys to enter an in point or press [RCL] and select a register or memory.

- [STO]

Store reg or mem	A→ 1:09:55:00
. . .	1:23:00:00

Store the value displayed in the calculator display area in the in point register.

- [7] (IN)

A* b t	A→ 1:09:55:00
. . .	(A) In: 1:23:00:00

The value is stored in the register.

**Enter Out Point**

- [3], [2], [1], [00], [00]

A* b t	A→ 1:09:55:00
. . .	3:21:00:00

Enter a value or use [RCL] to recall a value from a register or memory.

- [STO]

Store reg or mem	A→ 1:09:55:00
. . .	3:21:00:00

Store the value in the out point register.

- [8] (OUT)

A* b t	A→ 1:09:55:00
. . .	(A)Out: 3:21:00:00

The value is stored in the out point register. The duration is automatically calculated and stored in the duration register.

**Verify the Duration register contents**

- [RCL] + [9] (DUR)

A* b t	A→ 1:09:55:00
. . .	Dur: 1:58:00:00

Entering a different value in either the out point, in point, or duration registers will cause the duration to be recalculated.

## Auxiliary Function Keys

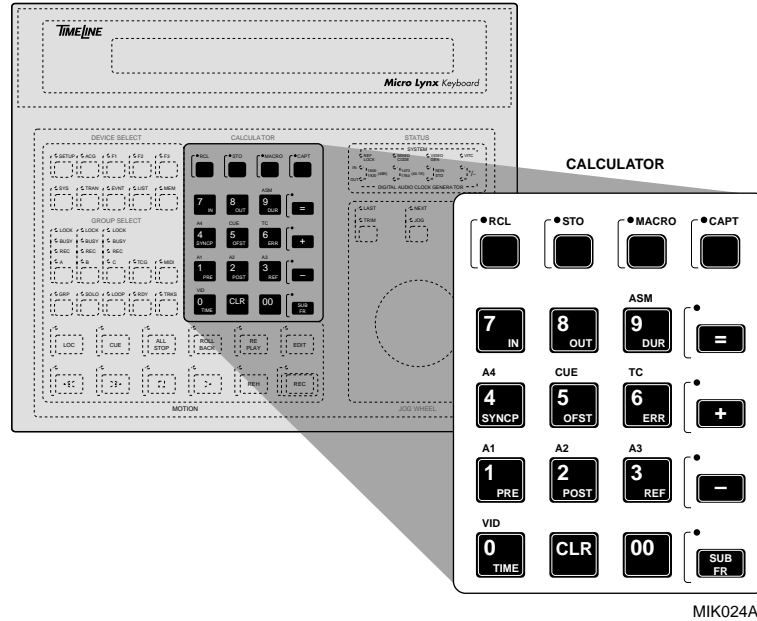

Figure Chapter 8 -9. Auxiliary Function Keys

The Auxiliary Function Keys are used to perform arithmetic operations with the calculator keys and in combination with other keys to facilitate Micro Lynx operations.

## RCL

The [RCL] key recalls time code values that are stored in the Micro Lynx registers and memories. Some registers are specific to each machine for example, sync point and offset. To display the sync point or offset for a machine, solo the machine or select group stat mode before recalling these registers.

### Procedure

1. [RCL]

*RCL LED flashes*

Recall reg or mem	A→ 1:03:47:17
-------------------	---------------

A calculator key selects a register or press [MEM] and calculator key to select a memory.

2. [7] (IN)

SOLO:A .	A→ 1:03:47:17
	(A) In: 1:23:00:00

The in point time code is displayed and the RCL LED turns off.

## STO

The [STO] key is used to store time code values in the Micro Lynx registers and memories. Press the [STO] key, “Store reg or mem,” will be displayed. Press one of the calculator keys to store the value in the calculator data entry buffer to the corresponding register. Press the [MEM] key followed by a memory number to store the value in a memory location.

Press [CLR] or [STO] again to cancel the command. The [STO] key can be used to store a value to any of the following registers.

Time  
 In Point  
 Out Point  
 Duration  
 Sync Point (select a machine first by pressing A-C or TCG)  
 Offset (select a machine first by pressing A-C or TCG)  
 Preroll  
 Postroll  
 Reference

If the currently selected machine is the reference machine, it is not possible to store an offset or sync point value. The following error message will be displayed:

Must be slave
---------------

Press a machine select key (A-C, TCG) to change the current machine to a slave transport.

The store function is automatically selected when you press the [CAPT] key. Requiring only the selected register or memory key to be pressed to store the time code value.

### Procedure

- [3], [1], [3], [0], [2], [2], [3]

SOLO:A .	A→ 1:03:47:17
	3:13:02:23

Enter (or recall) a time code value. 3:13:02:23

- [STO]

*STO LED flashes*

```
Store reg or mem      A→ 1:03:47:17
                      3:13:02:23
```

Press a calculator key to select a register or press [MEM] and a calculator key to select a memory.

- [7] (IN)

*STO LED turns off*

```
SOLO:A .              A→ 1:03:47:17
                      (A) In: 3:13:02:23
```

The time code is stored in the in point register.

## MACRO

The Micro Lynx has 10 programmable Macro keys. They can be programmed to execute any key sequence. Press [MACRO] followed by a number (0-9) to execute a macro sequence.

The [F1] and [F2] keys are short cut keys to macros (1 & 2). They are programmed by the factory to capture and store in, out, and cue points. Macro's 8 and 9 are also factory programmed to switch the Micro Lynx in and out of the correct mode for striping time code. It is possible to clear and reprogram these keys; however they will default to the factory settings if the keyboard is reset.

The message "Macro # executing" is displayed whenever a macro key is pressed.

### SETUP • MACRO

Press [SETUP] followed by [MACRO] and the macro number that you wish to program. Enter the key strokes in the correct sequence that the macro will run. Press the [MACRO] key again to save the sequence and exit, macro setup.

A macro sequence may not be included or nested within another macro sequence. To clear a macro, press and hold the [MACRO] key while pressing the number of the macro that you wish to clear.

### Procedure

- [SETUP] + [MACRO]

*MACRO LED flashes*

```
Program Macro:      0 - - - 4 5 6 7 - -
```

The macros that are not programmed are listed. Select a macro number.

2. [4]

SOLO:A .	A→ 1:03:47:17
----------	---------------

Select macro 4 to program, the display returns to normal operation.

3. [CAPT]

*CAPT LED flashes*

Store reg or mem	A→ 1:03:47:17
	1:03:47:17

A calculator key selects a register or press [MEM] and calculator key to select a memory.

4. [7] (IN)

SOLO:A .	A→ 1:03:47:17
	(A) In: 1:03:47:17

The time code is stored in the in point register.

5. [MACRO]

*MACRO LED turns off*

SOLO:A .	A→ 1:03:47:17
	(A) In: 1:03:47:17

The macro is programmed. In this sequence each time that Macro 4 is selected the current time code will be stored in the in point register. (This is the function that Macro 1 (F1) performs).

## CAPT

The [CAPT] key captures the current time code value for storage in any of the Micro Lynx registers or memories. When you press the [CAPT] key, the value of the time code shown in the display is instantly captured.

Press a register or memory key to store the time code value. If you do not want to store or save the value in a register, then press [CLR] or [CAPT] a second time.

### Procedure

1.

A* b+	A→03:13:02:23
. .	

You would like to capture this value and store it in the in point register.

2. [CAPT]

*CAPT LED flashes*

*STO LED flashes*

Store reg or mem	A→03:13:02:23
. .	03:13:02:23

The current time code is placed in the data entry buffer.

- [IN] (7)

*CAPT LED turns off*  
*STO LED turns off*

A* b+	A→03:13:02:23
. .	(A) In: 03:13:02:23

The time code is stored in the in point register.

## = (equal)

The Equal key is used in conjunction with the [+] and [-] keys to perform time calculations. It is used to complete a calculation sequence and when pressed, the sum or difference will be displayed. The answer is always displayed in the time code format of the master machine.

### Procedure

- [RCL] + [7] (IN)

A* b+	A→ 3:13:02:23
. .	(A) In: 3:47:17

Enter a value into the calculator display. If adding a value to an existing register, recall the register contents first.

- [+]  
2 0

A* b+	A→ 3:13:02:23
. .	plus 20

Enter number to be added.

- [=]

A* b+	A→ 3:13:02:23
. .	3:48:07

The answer is displayed in time code. Press [+] or [-] to begin a new calculation or [CLR] to return to the normal operating display.

## + (plus)

The [+] or addition key is used with the [=] key to add two values together.

Additions are computed in frames and displayed in the code type or format of the master machine. Press [CLR] to begin a new calculation or to return to the normal operating display. The arithmetic is correctly performed even if the numbers entered are

incorrectly formatted. For example, if you enter 1:65:43, it will be translated to 2:06:13 (30 frame calculation) during the calculation.

The [+] (plus) key is also used in setup to select the next option in a menu. It is used in TRIM mode to bump or increase the numerical value stored in a selected register by the trim register value.

**Procedure**

1. [1], [6], [5], [4], [3]

```
A* b+          A→ 3:13:02:23
. .           1:65:43
```

Enter the first number or press [RCL] and use the value in a register.

2. [+]
   
[2], [0], [0], [3], [4]

```
A* b+          A→ 3:13:02:23
. .           plus  2:00:34
```

Enter the second value.

3. [=]

```
A* b+          A→ 3:13:02:23
. .           4:07:17
```

The answer is displayed in time code (30 frame calculation). At this point you may decide to save this time code in another register.

4. [STO]

*STO LED flashes*

```
Store reg or mem  A→ 3:13:02:23
. .              4:07:17
```

Select a register or memory in which to store the value.

5. [IN] (7)

*STO LED turns off*

```
A* b+          A→ 3:13:02:23
. .           (A) In:  4:07:17
```

The sum is stored in the in point register.

6. [CLR]

```
A* b+          A→ 3:13:02:23
. .           0
```

The display returns to the normal operating display.

**– (minus)**

The [-] or minus key is used with the [=] key to subtract two time code values. Subtractions are computed in frames and displayed in the code type or format of the master machine. After perform-

ing the calculation, it may be stored to a register. Press [CLR] to begin a new calculation or return to the normal operating display.

The minus key is also used in setup to select the previous option in a menu and in TRIM to bump or decrease the numerical value stored in a selected register by the trim register value.

If you subtract a large number from a smaller one, the result will be displayed as a negative time code number.

**Procedure**

1. [1], [6], [5], [4], [3]

A* b+	A→ 3:13:02:23
. .	1:65:43

Enter the first number or press [RCL] and use the value in a register.

2. [-]  
[2], [0], [0], [3], [4]

A* b+	A→ 3:13:02:23
. .	minus 2:00:34

Enter the second value.

3. [=]

A* b+	A→ 3:13:02:23
. .	5:09

The answer is displayed in time code (30 frame calculation). At this point you may decide to save this time code in another register.

4. [STO]

*STO LED flashes*

Store reg or mem	A→ 3:13:02:23
. .	5:09

Select a register or memory in which to store the value.

5. [IN] (7)

*STO LED turns off*

A* b+	A→ 3:13:02:23
. .	(A) In: 5:09

The difference is stored in the in point register.

6. [CLR]

A* b+	A→ 3:13:02:23
. .	0

The display returns to the normal operating display.

## SUBFR

The Micro Lynx stores time code values in high resolution format. In normal operation, the high resolution or subframe content of all time code numbers except for the error display is suppressed.

Press the [SUBFR] key to enter or trim the subframe information. SUBFR is commonly used when adjusting offsets between machines. This can be done dynamically so that it is possible to easily adjust the positional relationship between machines until the audio phases.

Recall the offset for a slave machine that requires altering and press [TRIM] and [SUBFR]. The Jog Wheel and [+] and [-] keys can now be used to trim the offset register in subframe increments.

The Micro Lynx defaults to a subframe trim value of 01 subframes. See Setup SYS for information on how to alter the subframe increment value.

### Procedure

1. [B] + [RCL] + [OFST] (5)

```
STAT:b .                b→ 2:03:52:03
. .                    Ofst: 1:22:56:09
```

Recall the offset for a slave machine.

2. [TRIM] + [SUBFR] + Jog Wheel

```
STAT:b .                b→ 2:03:52:03
Trim by 0.01           Ofst: 1:22:56:08>00
```

The trim arrow points at the subframes. Turn the Jog Wheel or use the [+] and [-] keys to trim the offset register in subframe increments.

```
STAT:b .                b→ 2:03:52:03
Trim by 0.01           Ofst: 1:22:56:08>79
```

3. [TRIM]

```
STAT:b .                b→ 2:03:52:03
. .                    0
```

Exit trim mode. The trimmed value is automatically saved to the offset register.

4. [RCL] + [OFST] (5)

```
STAT:b .                b→ 2:03:52:03
. .                    Ofst: 1:22:56:08.79
```

If desired, recall the offset register to view the new offset.

## Status Indicators

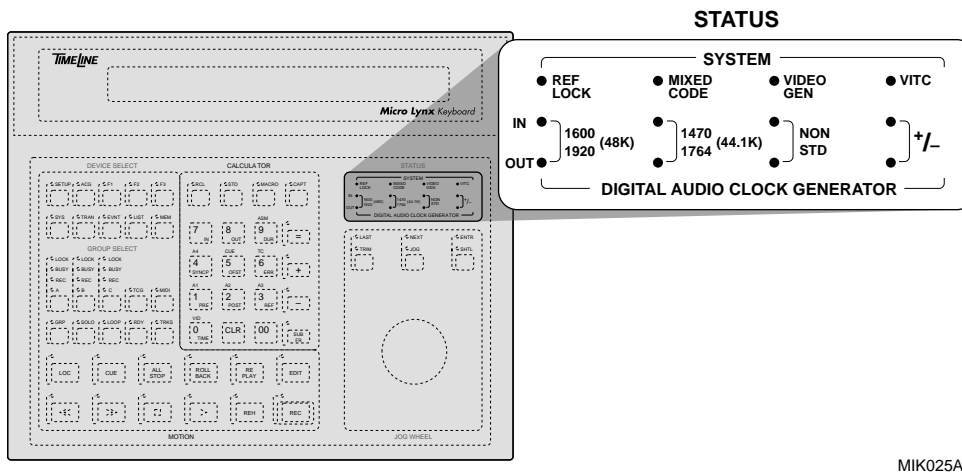

Figure Chapter 8 -10. Status Indicator

## System

**REF LOCK LED** This LED indicates the system speed reference status. If the LED is on then the system reference is present and the System Unit (SU) is locked.

If the LED is flashing it indicates that the reference selected is not present or that the system unit is unable to lock to the reference. For example, the REF LOCK LED would flash if ExtVid was selected as a system reference and an external feed of video sync was not present.

**MIXED CODE LED** This LED indicates that the system has detected mixed time code formats. If the LED is on it indicates that mixed and compatible types of time code have been detected. For example, 30 frame and drop frame code are different and yet compatible.

The LED will flash if the Micro Lynx time code generator is set to generate a time code type that is incompatible with the incoming reader time codes. For example, if the generator is set to 25 frame, but the machine time code readers are reading 30-frame code. The generator will then be automatically switched to the reference time code type. The LED will remain flashing if machine A, B or C reader time code types are incompatible. (Time code for A, B, C, TCG and MIDI must all be compatible.)

**VIDEO GEN LED** This LED indicates VSG option card status. If the LED is off, a VSG card is not installed in the system unit or the VSG is selected to off.

If the LED is on, the VSG is selected on and is ON (for instructions on how to select the VSG card see TCG options, item 6 in the Setup menu).

If the LED is flashing this indicates one of four VSG or system error states.

1. The VSG is selected on in the Setup menu, but the card is not installed.
2. The VSG is selected on and the system reference is set to ExtVID.
3. The VSG is selected on and the system frame rate is 24 Frame.
4. The VSG is selected off, the system reference is not set to ExtVid, and there is a released transport type in the group (a VTR or DTR).

### Procedure

*VIDEO GEN LED flashing*

Verify system reference setup.

1. [SETUP] + [TCG] + [0]

```

Setup:  TCG options
Selection: System Ref:  IntVar

```

Enter the TCG options menu.

2. [+]

```

Setup:  TCG options
Selection: System Ref:  ExtVid

```

Press [+] or [-] until ExtVid is selected.

3. [SETUP]

*VIDEO GEN LED turns off*

**VITC LED** This LED indicates VITC reader card status. If the LED is on, the reader is detecting valid VITC data (matching line pair), from the selected video machine.

## Digital Audio Clock Generator LEDs

The Digital Audio Clock Generator LEDs indicate the status of the ACG card. The LEDs directly reflect the parameters that have been set in the ACG options under the Setup menu. There are two rows of LEDs the upper row is for ACG inputs and the lower row is for ACG outputs.

- IN 1600/1920** This LED indicates that an ACG input sample rate ratio of either 1600 samples-per-frame at 30 Hz or 1920 samples-per-frame at 25 Hz has been set. This is a nominal sample rate of 48,000 Ks/s. This LED should be read in conjunction with the NON STD and +/- LEDs. If this LED flashes, it indicates that the ACG Card has not locked to the incoming signal.
- OUT 1600/1920** This LED indicates that an ACG output sample rate ratio of either 1600 samples-per-frame at 30 Hz or 1920 samples-per-frame at 25 Hz has been set. It is a nominal sample rate of 48,000 Ks/s. This LED should be read in conjunction with the NON STD and +/- LEDs. If this LED flashes, it indicates that the ACG output is not locked.
- IN 1470/1764** This LED indicates that an ACG input sample rate ratio of either 1470 samples-per-frame at 30 Hz or 1764 samples-per-frame at 25 Hz has been set. This is a nominal sample rate of 44,100 Ks/s. This LED should be read in conjunction with the NON STD and +/- LEDs. If this LED flashes, it indicates that the ACG Card has not locked to the incoming signal.
- OUT 1470/1764** This LED indicates that an ACG output sample rate ratio of either 1470 samples-per-frame at 30 Hz or 1764 samples-per-frame at 25 Hz has been set. This is a nominal sample rate of 44,100 Ks/s. This LED should be read in conjunction with the NON STD and +/- LEDs. If this LED flashes, it indicates that the ACG output is not locked.
- NON STD IN** If only this LED is on, it indicates that an ACG input sample rate ratio of either 1066 2/3 samples-per-frame at 30 Hz or 1280 samples-per-frame at 25 Hz has been set. This is a nominal sample rate of 32,000 Ks/s. If this LED flashes, it indicates that the ACG Card has not locked to the incoming signal.

If the LED is on in combination with one of the previous two input LEDs, it indicates that the nominal sample rate ratio is being varied. If it is on with 1600/1920 for 48,000 Ks/s and with 1470/1764 for 44,100 Ks/s. There is no specific indication when a 32,000 Ks/s input is being varied.

**NON STD OUT** If only this LED is on it indicates that an ACG output sample rate ratio of either 1066 2/3 samples-per-frame at 30 Hz or 1280 samples-per-frame at 25 Hz has been set. This is a nominal sample rate of 32,000 Ks/s. If this LED flashes it indicates that the ACG output is not locked.

If the LED is on in combination with one of the previous two output LEDs, it indicates that the nominal sample rate ratio is being varied. If it is turned on with 1600/1920 for 48,000 Ks/s, and with 1470/1764 for 44,100 Ks/s. There is no specific indication when a 32,000 Ks/s output is being varied.

**+/- IN** This LED operates in combination with the previous input LEDs and indicates that the selected input sample rate ratio has been automatically pulled up or down by 0.1%; for example, from 48,000 to 47,952 or from 44,100 to 44,056.

When the nominal sample rate is selected, the ACG card will automatically adjust the sample rate ratio by +0.1% if the sample rate requested requires a pull up because the system frame rate is running at 29.97 Hz instead of 30/25/24 Hz. Or it will automatically adjust the sample rate ratio by -0.1% if the sample rate requires a pull down because the system frame rate is running at 30/25/24 Hz instead of 29.97 Hz.

**+/- OUT** This LED operates in combination with the previous output LEDs. It indicates that the selected output sample rate ratio has been automatically pulled up or down by 0.1%; for example from 48,000 to 47,952 or from 44,100 to 44,056.

When the nominal sample rate is selected, the ACG card will automatically adjust the sample rate ratio by +0.1% if the sample rate requested requires a pull up because the system frame rate is running at 29.97 Hz instead of 30/25/24 Hz. Or it will automatically adjust the sample rate ratio by -0.1% if the sample rate requires a pull down because the system frame rate is running at 30/25/24 Hz instead of 29.97 Hz.



## Chapter 9 Advanced Features

---

### Using AVID AudioVision with the Micro Lynx

AudioVision Version 2.0 includes support of TimeLine Vista, Inc.'s Micro Lynx synchronizer. Using the Micro Lynx with AudioVision will enable you to control many external decks that cannot be directly controlled using Sony 9-pin protocol. The Micro Lynx also allows you to output time code from AudioVision and slave AudioVision from an external time code source.

This section outlines the basic steps necessary to connect the Micro Lynx to AudioVision and use it to control one or multiple decks. It is assumed that you are familiar with operating the Micro Lynx, or that you have read the Getting Started section of the user's manual. If you are not already familiar with the Micro Lynx, read the appropriate sections before attempting to use it with AudioVision.

On power up, AudioVision automatically configures the Micro Lynx for correct operation. The following setup options are initialized by AudioVision:

- The Mac computer port is set for ES bus operation.
- Park Window is set to zero.
- Group park ahead is set to zero.
- Ref follow master is set to on.
- The System reference is set External Video, unless a VSG (video sync generator) board is fitted, then it will be set to Internal fixed.
- The ACG card input and output is set to 44.100 KHz and the Oversample rate to 256.

To complete the configuration, all that has to be selected is the type of transport to be controlled.

The Avid system requires that a transport be selected for an Avid node to be active. If it is intended to use AudioVision in slave mode, to a time code “feed” with no transport connected, we recommend that an ATR transport be selected.

## To Control One Transport Device with the Micro Lynx

1. With all hardware powered off, connect a machine control cable and a time code cable between the Micro Lynx and the deck you want to control. The machine control cable is connected from the Micro Lynx's Transport 1 connector to the deck's remote control input, and the time code cable is connected from the deck to the RDR 1 input on the Micro Lynx.
2. Use a standard Macintosh printer cable to connect your Macintosh's modem port to the Micro Lynx's Macintosh port.  
**Note:** Be sure to use a standard Macintosh printer cable to connect the Mac to the Micro Lynx, not a Mac to 9-pin cable. Connecting the Mac to the Micro Lynx's 9-pin port can result in inaccuracies in time code when digitizing material into AudioVision.
3. Connect a black burst source to the Video Ref port on the Micro Lynx, and to the video machine you are controlling.
4. Use a BNC cable to connect the ACG-2 card's OS OUT (on the Micro Lynx) to the first Digidesign Audio Interface's Slave Clock input.
5. Power on the Micro Lynx.
6. On the Micro Lynx Keyboard, the group select keys will flash, press machine key A.
7. Next, you need to specify the type of machine you are using. Enter setup mode in the Micro Lynx by pressing the [SETUP] key on the keyboard. Press the [TRAN] key to select the type of machine you are synchronizing. Use the [Next/Last] and [+] and [-] keys to select the correct type from the menu.  
**Note:** If your deck does not appear in the menu, refer to the Appendix, Table 2, for alternate choices.
8. While in setup mode, the default option settings initialized by AudioVision can be checked by pressing the respective option key and the [Last/Next] keys to step to the desired menu. For example, press the [TCG] key and use the [Last/Next] keys to select the System Ref menu. This should normally be set to Ext Vid. For a complete list of setup options, please see the Appendix.

9. Press the [SETUP] key to leave setup mode.
10. Set up AudioVision in Master Mode just as you would if you were using Sony protocol or VLANs. You are now ready to synchronize the Micro Lynx to AudioVision.

**Note:** The Micro Lynx will remember the settings you have programmed when you power down, there is no need to repeat the setup steps every time you use the system.

### **To Control Multiple Transport Devices with the Micro Lynx**

Follow the above steps, but repeat steps 6 and 7 for each additional deck. In Step 6, select A for Deck 1, B for Deck 2, etc.

### **To Slave AudioVision from an External Deck Connected to the Micro Lynx**

1. If you are only going to slave AudioVision from an external deck, and don't need to operate AudioVision in Master Mode, you only need to connect the time code cable from the machine to the Micro Lynx.
2. Follow the above directions, but set AudioVision to Slave Mode from the Deck Control window. AudioVision is now set to slave to the deck connected to the Micro Lynx.

## Using Pro Tools with the Micro Lynx

### Introduction

The Micro Lynx machine control system has special features that make it suitable for use with DigiDesign Pro Tools digital audio workstations.

- The MIDI and SMPTE time code generators can be synchronized with the tape machine group; operating as virtual tape machines, chasing the reference machine time code numbers.
- If the MTC output is connected to Pro Tools, the workstation will run as if it were a tape machine. This also holds true for MIDI synthesizers and MIDI mapping systems.
- The Micro Lynx is specifically designed to generate a digital clock speed reference for digital work stations. The Audio Clock Generator option cards (ACG-1 & 2) generate locked, digital audio clock signals to control the play speed or sample rate of digital equipment.
- Pro Tools is very similar in operation to a video tape machine, in that it uses time code for position, but when in play, “releases” to an internal or external reference, which then controls its speed and position. The ACG can be used as the Pro Tools reference.
- If the Micro Lynx is equipped with a VITC Option Card, it will update the MIDI time code position for Pro Tools in Jog, Shuttle and still modes, from VITC stripped on the video tape. This allows an accurate method of “spotting” current VITC frame numbers to Pro Tools for sound effects and post production work.
- The Micro Lynx provides two operating modes for the Pro Tools System. First, the Pro Tools System may be slaved to the Micro Lynx system reference and Master time code. Secondly, the Pro Tools System can run as the master transport, thereby slaving the machine group in the Micro Lynx. Both methods are described here in detail.

## System Set Up And Configuration: Pro Tools as Slave

### ACG to Pro Tools Audio Interface Connections

1. Connect the ACG (1 or 2) O.S. OUT to the SLAVE CLOCK IN on the first Pro Tools Audio Interface.
2. When the Micro Lynx is on, the ACG card will automatically generate word and over sample clock, locked to the system reference. The Pro Tools Audio Interface switches internally from Master Sync mode to Slave Sync mode. Use the ACG Setup menu, in the Micro Lynx, to set the Oversample Output to 256 (this is the default).

**Note:** DigiDesign strongly recommends that the BNC cable from the O.S. OUT to the Pro Tools Audio Interface be no longer than four feet.

### Procedure

1. [SETUP]  
[ACG]

```
Setup:  ACG Options
Selection:  NOM S/Rate Out  48.000 ks/s
```

You are in the ACG setup menu.

2. [LAST/NEXT]

```
Setup:  ACG Options
Selection:  Oversample Out: 256
```

Select Oversample menu.

3. [+] and [-]

Use to select the correct Oversample rate.

3. Check that only the SLAVE CLOCK LED on the Pro Tools interface is on. If both Slave and Master LEDs are on, the digital input has been selected as the clock source. For correct operation, set digital input to OFF in the Pro Tools software.
4. Confirm that the Nominal S-Rate (Sample Rate) Output on the ACG matches that of the Pro Tools Session sample rate.

### Procedure

1. [SETUP]  
[ACG]

```
Setup:  ACG Options
Selection:  NOM S/Rate Out  48.000 ks/s
```

You are in the ACG setup menu.

2. [+] and [-]

Use to select the correct sample rate.

### Micro Lynx to Computer Connections

1. Connect a standard Macintosh printer cable to the Macintosh modem port and the Micro Lynx MAC computer port or MIDI I/F connector.
2. For Pro Tools to receive MIDI time code, several routing options are available. MTC can be sent directly to the Macintosh printer or modem ports via the MAC, or I/F connectors. This eliminates the need for a MIDI Translator. If required for other MIDI system reasons, MTC can be simultaneously generated from the 5-pin DIN, MIDI OUT or THRU/OUT connectors.

#### Procedure

1. [SETUP]  
[MIDI]

Setup: MIDI
Selection: MIDI OUT Jack: MTC

Select MIDI port setup.

2. [LAST/NEXT]

Setup: MIDI
Selection: MAC OUT Jack: MTC

Select the port you wish to use for MTC.

3. [+] and [-]

Use to select chosen port for MTC.

3. Add the TCG to the Micro Lynx machine group. The time code generator (TCG) of the Micro Lynx now transmits MIDI time code, based on the time code from the Reference machine. Use the TCG options menu in setup mode, to select the time code type and generation method.
4. The generator will always jam to the incoming reader code, and should be set to Play/Wind to follow group transport operation. Refer to TCG Option Menu in the Keyboard Controller section of the Micro Lynx Manual, for option setting choices.

**Note:** Anytime the TCG is put in the group, or put into play, MTC will be transmitted from the selected MAC or MIDI connectors.

5. Set the system reference for your specific application. The ACG output and each of the machines in the system will all lock to the selected system reference, thus ensuring correct synchronization.

#### Procedure

1. [SETUP]  
[TCG]

```
Setup:  TCG Options
Selection: System Ref IntFix
```

2. [+] and [-]

Select the system reference required.

6. Set the required frame rate and code type in the Micro Lynx TCG Setup options menu.

#### Procedure

1. [SETUP]  
[TCG]

```
Setup:  TCG Options
Selection: System Ref IntFix
```

TCG setup option menu

2. [LAST/NEXT]

```
Setup:  TCG Options
Selection: System Spd/Code: 29.97Hz/30
```

3. [+] and [-]

Select frame rate and code type required. This should be the same as the Pro Tools code type and rate.

7. Power up the Micro Lynx after the Macintosh computer. If the Macintosh plays a short melody during startup and won't boot, turn the Micro Lynx off and reboot the Macintosh.
8. Make sure that Appletalk is inactive in the Chooser.
9. Verify that the time code rate and type, in the Pro Tools Option SMPTE format menu, match those selected in the TCG Setup options on the Micro Lynx.
10. In the Pro Tools Options menu, set Continuous Resync to OFF, and Online to ON.
11. Set the time code start frame to the program material's starting time code.

## VITC Option Card Setup and Configuration for Pro Tools

A useful feature of Pro Tools is its capability to capture a MIDI time code number, for use in its Spotting mode for sound effects layback. The Micro Lynx VITC Option Card can provide Pro Tools with an MTC number, based on the current VITC number being decoded from the video machines video output. This allows frame accurate update of current time code position in Jog, Shuttle and Still modes.

The operation of the VITC Option Card is simple and automatic as described in the setup operations below.

### Procedure

1. [SETUP]  
[F3]

```
Setup: VITC Options
Selection: Group Select Off
```

VITC setup option menu

2. [+] and [-]  
Select the transport that is connected to the VITC card.
3. [LAST/NEXT]

```
Setup: VITC Options
Selection: Reader Mode: Auto
```

Set correct scan mode.

The Micro Lynx TCG needs to be set as follows for the MIDI time code generator to operate correctly.

### Procedure

1. [SETUP]  
[TCG]

```
Setup: VITC Options
Selection: TCG Group Mode: Play, Wind
```

Set the TCG Group mode to Play, Wind.

2. [LAST/NEXT]

```
Setup: VITC Options
Selection: TCG Still Mode: On
```

Set the TCG Still mode to On.

## System Setup And Configuration: Pro Tools as Master

When using Pro Tools as a Master, set up Pro Tools and the Micro Lynx for Slave operation, as previously described. In Master mode, the Micro Lynx reads MTC from Pro Tools and will control the transports so they chase and lock to the Pro Tools time code position.

- The Pro Tools System may be used as the master transport in the Micro Lynx. In this configuration, the MIDI machine selection on the Micro Lynx is put into the group, and the tape machines will chase as slaves to the incoming MIDI time code.
- With MIDI in the transport group, the Micro Lynx requires that MIDI be the master. Once GRP + MIDI is pressed, MIDI will automatically become the master machine.
- The Micro Lynx ACG 1 & 2 cards provide the speed reference for the Pro Tools System.
- With MIDI Resolve ACG Servo option selected, the ACG clock signal is servoed so that the incoming MIDI time code edge is aligned with the system reference (for example, EXT VIDEO).
- The ACG Servo option is only required when Pro Tools is used as a Master. If Pro Tools has to be locked to video, then the MTC generated by Pro Tools in MIDI Master mode must have a fixed relationship with video sync. The ACG Servo option is used to accurately advance or retard the position of the Pro Tools digital Audio, so it has a precise and repeatable relationship with the video, thus ensuring perfect MIDI time code synchronization.

For the Micro Lynx to receive MTC from Pro Tools, you must select the MIDI input you wish to use.

### Procedure

#### Set MTC Source

1. [SETUP]  
[MIDI]

```

Setup:  MIDI Options
Selection:  MIDI Out Jack:  MTC

```

Enter MIDI options setup menu.

2. [LAST/NEXT]  
or [4]

```

Setup:  MIDI Options
Selection:  MTC Source:  MIDI In Jack

```

Press [4] or [Last/Next] until the MTC source menu is displayed.

3. [+] and [-]

```
Setup:  MIDI Options
Selection:  MTC Source:  I/F Jack
```

Use [+] and [-] to select the input connector you wish to use.

or

```
Setup:  MIDI Options
Selection:  MTC Source:  MAC Jack
```

**Set MIDI Resolve**

**Procedure**

1. [SETUP]  
[MIDI]

```
Setup:  MIDI Options
Selection:  MIDI Out Jack:  MTC
```

Enter MIDI options setup menu.

2. [LAST/NEXT]  
or [6]

```
Setup:  MIDI Options
Selection:  MIDI Resolve:  Off
```

Press [6] or [Last/Next] until the MIDI Resolve menu is displayed.

3. [+] and [-]

```
Setup:  MIDI Options
Selection:  MIDI Resolve:  ACG Servo
```

Select ACG Servo.

## Advanced MIDI Features

With Micro Lynx software version 1.30 and later, the MIDI capabilities were enhanced for more versatile operation. These features and the MIDI Setup Menu are described in this section.

### General Features

- User selectable MIDI MTC input source.
- MTC to LTC conversion.
- MIDI translator - 5-pin to 8-pin MAC feature.
- Comprehensive MIDI data and MTC routing matrix.
- MTC to digital audio word clock workstation resolve function.
- MIDI time code as master is now implemented. This allows Micro Lynx group slaves to case lock to incoming MTC.

### MIDI Setup Menu

Table 9-1 is a complete list of the Micro Lynx setup options for MIDI. Figure 9-1 is a block diagram of the MIDI routing. Explanation for each menu item is also included.

Press the [SETUP] key to enter setup mode. The SETUP LED will flash. Next press the [MIDI] key. After modifying the selected options, exit setup mode by pressing [SETUP] a second time. Each menu can be accessed directly by selecting it numerically, or sequentially by pressing the [LAST] and [NEXT] keys. The individual options are stepped through by pressing the [+] and [-] keys.

**Table Chapter 9 -1. Micro Lynx MIDI Setup Selections**

KEY	MENU	SUB-MENU	RANGE
MIDI	MIDI Options	0 MIDI Out Jack	Off, MTC, MIDI Data, MTC + Data, I/F Thru
		1 I/F Out Jack	Off, MTC, MIDI Data, MTC + Data, MIDI Thru
		2 MAC Out Jack	Off, MTC, MIDI Data, MTC + Data
		3 MIDI Thru Jack	MIDI In, MIDI Out
		4 MTC Source	MIDI In Jack, I/F Jack, MAC Jack
		5 MIDI Data Src	MIDI In Jack, I/F Jack, I/F Jack
		6 MIDI Resolve	Off, ACG Servo

## Description Of Settings

Please note that MIDI time code output from the Micro Lynx is a function of the time code generator. You must group the TCG with the other machines in the group for MTC output.

### Midi Out Jack

**Off.** Connector will not output any signal.

**MTC.** Connector will output MIDI time code.

**MIDI Data.** Connector will output Micro Lynx MIDI data. (Not available at this time.)

**MTC + Data.** Connector will output MIDI time code and MIDI data simultaneously. (Not available at this time.)

**IF/Thru.** Connector will thru put MIDI information that has been input to the 8-pin I/F connector.

### I/F Out Jack

**Off.** Connector will not output any signal.

**MTC.** Connector will output MIDI time code.

**MIDI Data.** Connector will output Micro Lynx MIDI data. (Not available at this time.)

**MTC + Data.** Connector will output MIDI time code and MIDI data simultaneously. (Not available at this time.)

**MIDI Thru.** Connector will thru put data that has been input to the 5-pin MIDI input connector.

### MAC Out Jack

**Off.** Connector will not output any signal.

**MTC.** Connector will output MIDI time code.

**MIDI Data.** Connector will output Micro Lynx MIDI data. (Not available at this time.)

**MTC + Data.** Connector will output MIDI time code and MIDI data simultaneously. (Not available at this time.)

### MIDI Thru Jack

**MIDI In.** MIDI thru jack outputs data from MIDI In jack.

**MIDI Out.** MIDI thru jack outputs MIDI out data.

### MTC Source

**MIDI In Jack.** MIDI time code source is the MIDI In jack.

**I/F Jack.** MIDI time code source is the I/F jack.

**MAC Jack.** MIDI time code source is the MAC jack.

### MIDI Data Source

**MIDI In Jack.** MIDI data source is the Midi In jack.

**I/F Jack.** MIDI data source is the I/F jack.

**MAC Jack.** MIDI data source is the MAC jack.

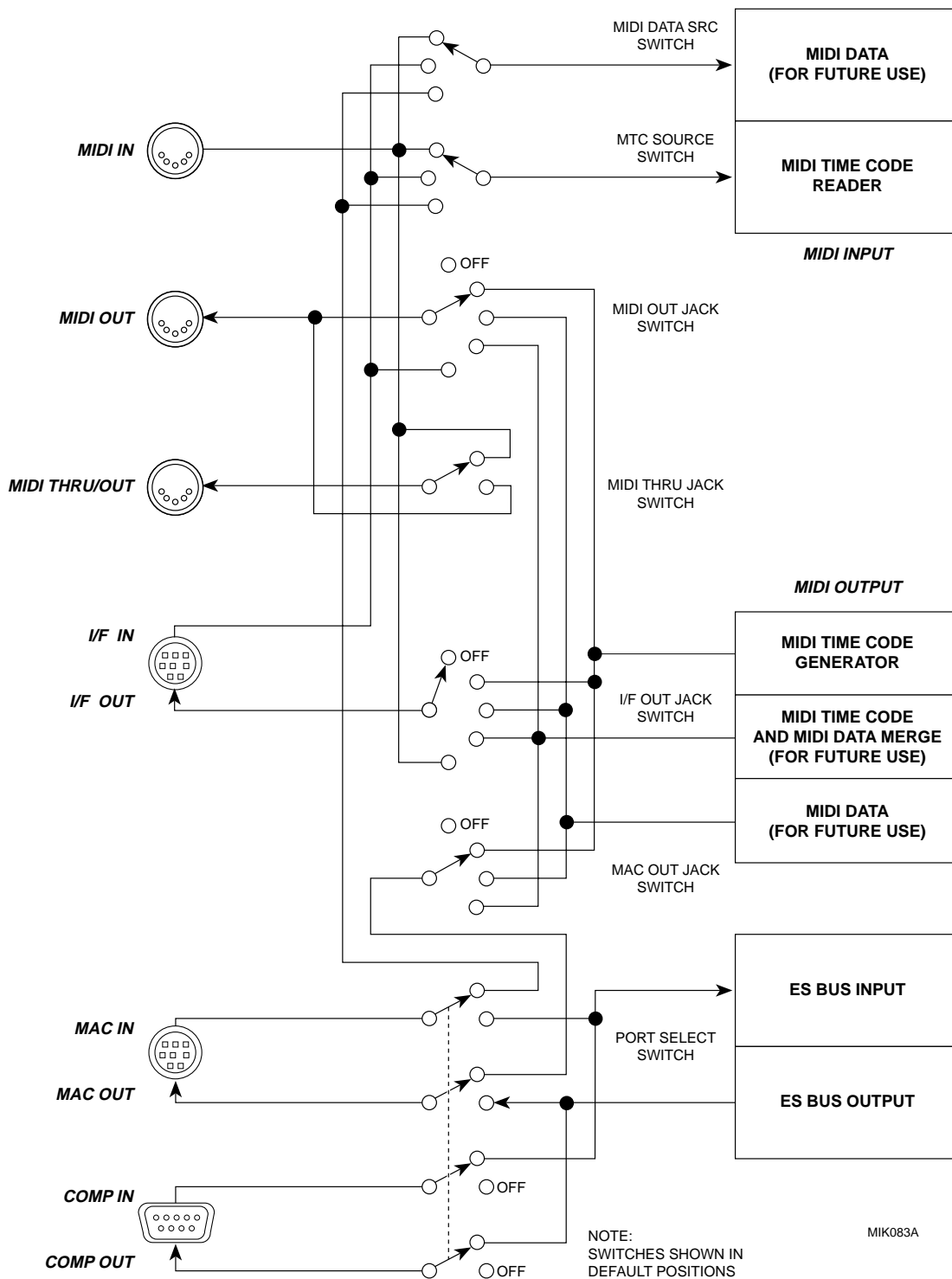

Figure Chapter 9 -1. MIDI Routing

## Other Setting Descriptions

The following settings are relevant to the System Setup covered in the Keyboard Controller section.

**Port Select MAC**

**MIDI.** MAC port will accept MIDI or MTC input.

**ES.** MAC port will accept ES Bus communications.

**Port Select RS422**

**ES.** RS422 connector will accept RS422 serial communications.

**Off.** RS422 connector is turned off.

---

# Using Mediasound with the Micro Lynx

## Introduction

The Micro Lynx is a synchronizer that allows you to control up to three machines. It also generates locked SMPTE, EBU, and MIDI time codes. The Micro Lynx is composed of a system unit and a keyboard controller.

The Micro Lynx reads SMPTE or EBU time code from the VTR or ATR (drop frame or non-drop frame), converts it to MIDI Time Code (MTC), and sends it to the SGI workstation serial port 2. The Micro Lynx also generates sample clock information that is locked to the tape machine speed references, and sends it to the digital I/O port on the SGI workstation.

The Micro Lynx Keyboard Controller is the system controller for the external machine and the Mediasound Transport on the SGI workstation. When Mediasound is in Chase mode, the Micro Lynx Play or Stop buttons operate the external machine and the SGI workstation at the same time:

- ✧ When the Micro Lynx is playing forward at normal play speed, Mediasound synchronizes to it and begins to play.
- ✧ When the Micro Lynx stops, Mediasound locates to the time displayed in the MIDI Time Code Display (MTC in the Group Control Area).

As a slave, the SGI workstation chases the VTR/ATR master and always locates to the point that the Micro Lynx MIDI time code stream stops. If you rewind the VTR/ATR to cue to a particular frame, the Mediasound Transport jumps to the point where the VTR/ATR stops.

## Micro Lynx Options Necessary for Video Sync

To properly lock to video, two Micro Lynx options are required:

- ✧ **ACG (Audio Clock Generator).** The ACG card is a synchronized digital audio sampling clock interface. It outputs digital audio sample rate clocks that are synchronized to the system reference. The clock card takes video frame information (black burst or composite sync) and converts it to audio clock signals. The AES/EBU output of this card is plugged into the digital I/O port on the SGI workstation.
- ✧ **VSG (Video Sync Generator).** The VSG card is a sync pulse generator that outputs NTSC or PAL composite sync. This signal is typically routed to the External Sync inputs of video decks in the system.

For information on installing a Micro Lynx and an external VTR or ATR to the SGI workstation, see *Using Mediasound with the Micro Lynx* later in this chapter. Detailed instructions for using the Micro Lynx are in the Micro Lynx manual.

## Using Mediasound with the Micro Lynx

The Micro Lynx synchronizer includes special support for Mediasound. Using the Micro Lynx with Mediasound will enable you to control Mediasound with external video or tape decks. The Micro Lynx also allows you to output the Mediasound time code position (LTC) when Mediasound is in Chase mode, and slave Mediasound to an external time code source.

This section outlines the basic steps necessary to connect the Micro Lynx to Mediasound, and use it to control the workstation with one or multiple decks. It is assumed that you are familiar with operating the Micro Lynx or that you have read the Getting Started section of the Micro Lynx User's Manual. If you are not already familiar with the Micro Lynx, read the manual before you attempt to use the Micro Lynx with Mediasound.

The Micro Lynx machine control system has a number of special features that make it ideal for use with Mediasound digital audio software running on SGI workstations.

- ✧ The MIDI and SMPTE time code generators can be synchronized with the tape machine group, operating as a virtual tape machine that chases the reference machine time code numbers.
- ✧ If the MTC output is connected to the serial port on the SGI workstation running Mediasound, the workstation will run as if it were a slave tape machine.
- ✧ Mediasound is similar to a video tape machine in that it uses time code (in this case MIDI time code) for positional synchronization. However, when Mediasound is in play, it releases to an external AES/EBU digital audio reference, which then controls its speed and position.
- ✧ The Micro Lynx is specifically designed to generate a digital audio clock reference for digital workstations. The Audio Clock Generator Card (ACG-2) generates locked, digital audio clock signals to control the play speed or sample rate of digital equipment.

- ✧ If the Micro Lynx is equipped with a VITC Option Card, it will update the MIDI time code position for Mediasound in jog, shuttle and still modes, from VITC striped on the video tape. This allows an accurate method of spotting current VITC frame numbers to Mediasound for sound effects and post production work.

Unless the feature is specifically disabled, Mediasound is automatically configured for correct operation by the Micro Lynx when Mediasound is put into Chase mode. The following options are initialized by the Micro Lynx:

- ✧ The time code type: 24 (film), 25 (EBU), 30 Drop, or Non Drop (SMPTE) codes.
- ✧ The system frame rate: 24, 25, 29.97, or 30 frames per second.
- ✧ The sample rate: 32.000, 44.100, or 48.000 kHz. If an NTSC 0.1% pull down is selected, the sample rates will be 31,968, 44,056, and 47,952 kHz. Non-standard and variable rates can also be set.

To complete the system configuration, you need to select the type of video or tape transport to be controlled by the Micro Lynx.

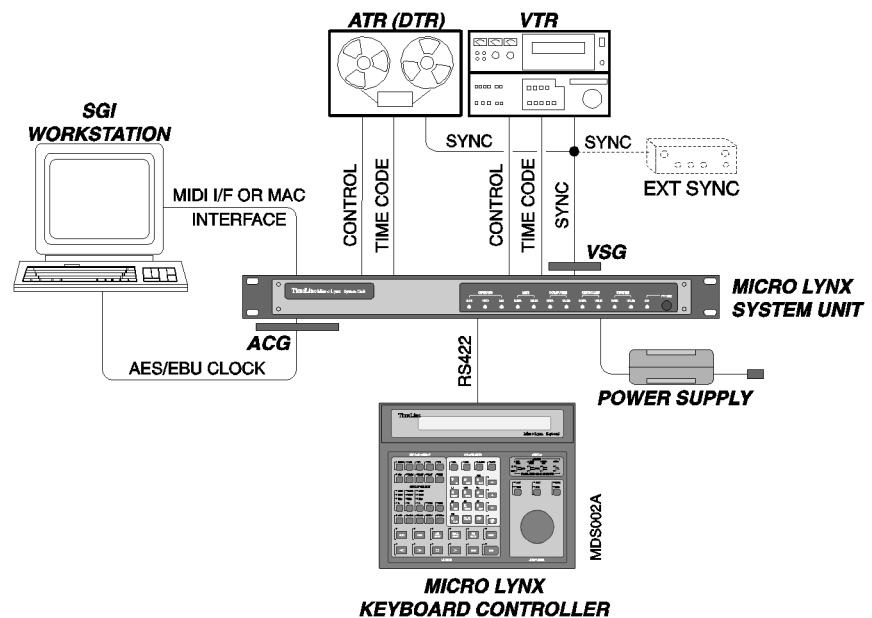

Figure Chapter 9 -2. Micro Lynx with an SGI Workstation

## Micro Lynx to Computer Connections

- ✧ Connect the ACG AES/EBU output to the SGI workstation Digital I/O jack, using the supplied cables.

**Note:** The workstation's digital audio output is available at the unattached plug of the supplied "Y" cable.

- ✧ Connect a standard Macintosh printer cable (supplied) between the SGI workstation Serial Port 2 and the Micro Lynx MIDI I/F connector.

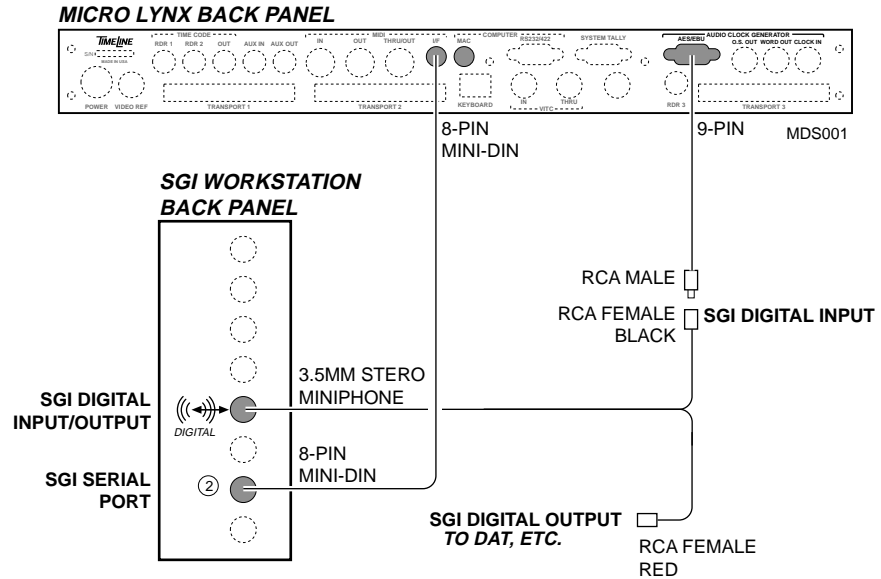

Figure Chapter 9 -3. Micro Lynx to SGI Workstation Connections

## Micro Lynx to VTR Connections (Typical)

The Micro Lynx is compatible with many video transports that support external synchronization, including standard 3/4-inch U-matic, Beta, S-VHS, VHS, open reel, and digital VTRs. With a Micro Lynx, the video machines are always resolved, so they can be run as either Master or Slave. If the VTR uses Sony Serial Protocol, serial time code can be used as the time code source.

Use an external video sync source as a speed reference source for the Micro Lynx and VTR. Install the Micro Lynx Video Sync Generator Card (VSG), if an external sync source is not available.

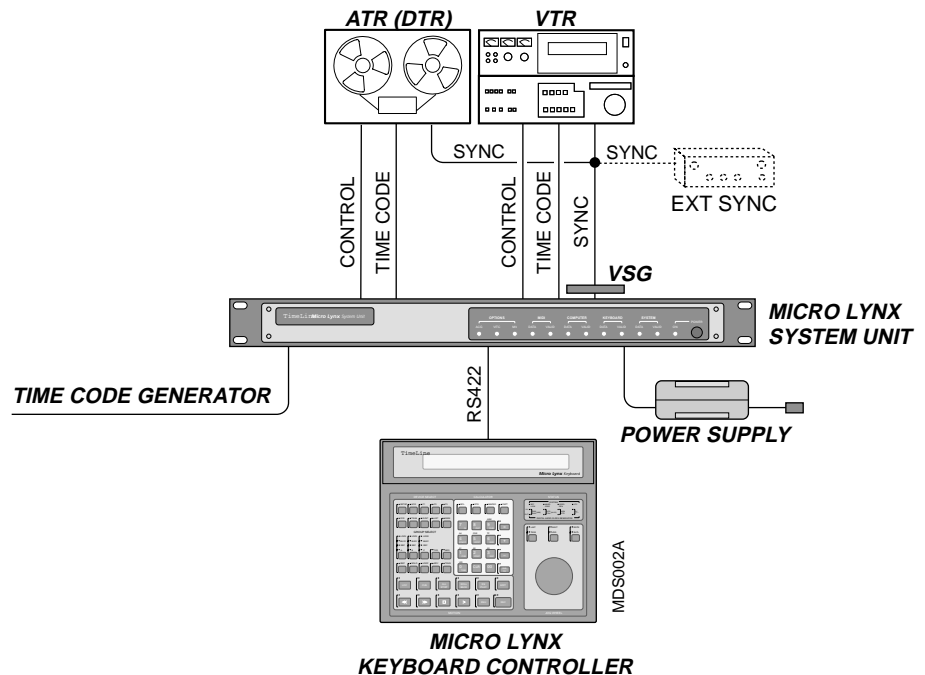

Figure Chapter 9 -4. Micro Lynx to VTR Connections

# Micro Lynx Setup

## Audio Clock Generator Setup

The AES/EBU Audio Clock Generator produces a digital audio bit stream locked to the Micro Lynx system reference. This information is used by the SGI workstation to control the play speed of the digital audio.

Set the desired sample rate using the Nominal S/Rate Out section of the SETUP ACG Menu. When Mediasound is in Chase mode, it automatically detects and adjusts to this setting.

On the Micro Lynx Keyboard press the [SETUP] key followed by the [ACG] key. These two keys are next to each other in the top left corner of the keyboard. Pressing [SETUP] puts the Micro Lynx into setup mode, which is used to configure the system. The [Last/Next] keys are used to step through setup options and the [+/-] keys are used to select the required parameters.

**Note:** In the following instructions, it is not necessary to exit setup mode after each step.

### Procedure

Set the system sample rate.

1. [SETUP], [ACG]

Setup: ACG Options Selection: NOM S/Rate Out 44.100 ks/s
---

You are in the ACG Setup Menu.

2. [+/-]

Use to select the correct sample rate.

3. [SETUP]

Exit Setup mode.

Set the ACG variable rate output option to Off.

### Procedure

1. [SETUP], [ACG]

Setup: ACG Options Selection: NOM S/Rate Out 44.100 ks/s
---

Select ACG setup.

2. [Last]/[Next]

```

Setup: ACG Options
Selection: Var Ratio Out: Off

```

3. [+/-]

Use to turn Variable Ratio Output off.

4. [SETUP]

Exit Setup mode.

## MIDI Time Code Setup

The Micro Lynx generates MIDI time code (MTC), which is used by Mediasound for positional synchronization. MTC can be transmitted from either the Micro Lynx MAC or MIDI I/F ports.

Set the appropriate MIDI port to Output MTC.

### Procedure

1. [SETUP], [MIDI]

```

Setup: MIDI
Selection: MIDI OUT Jack: MTC

```

Select MIDI port setup.

2. [Last]/[Next]

```

Setup: MIDI
Selection: I/F Out Jack: MTC

```

3. [Last]/[Next]

```

Setup: MIDI
Selection: MAC OUT Jack: MTC

```

Select the port you wish to use for MTC.

4. [+/-]

Use to select MTC as the MIDI output.

5. [SETUP]

Exit Setup mode.

## MIDI Data Source Setup

The Micro Lynx is switched by Mediasound to transmit the time code type, frame rate and sample rate with the MTC over the MIDI port. The correct port must be selected.

Set the MIDI Data Source to the same MIDI port that was selected in the previous step.

### Procedure

1. [SETUP], [MIDI]

```
Setup: MIDI
Selection: MIDI OUT Jack: MTC
```

Select MIDI port setup.

2. [Last]/[Next]

```
Setup: MIDI
Selection: MIDI Data Src: MAC Jack
```

Select the MIDI Data Source option.

3. [+/-]

```
Setup: MIDI
Selection: MIDI Data Src: I/F Jack
```

Use to select chosen port for MIDI Data Source.

4. [SETUP]

Exit Setup mode.

## System Reference Setup

The Micro Lynx system reference is used to set the reference time base for all of the equipment in the system. If you are using a video tape transport that is connected to an external video sync generator, connect the sync source to the Micro Lynx and select ExtVid as the system reference. Otherwise, select IntFix. The Micro Lynx has an internal video sync generator (VSG) that it uses when no external video sync is available.

Set the system reference for your specific application. The ACG output and each of the tape machines in the system will lock to the selected system reference, which ensures correct synchronization.

**Procedure**

1. [SETUP], [TCG]

```

Setup: TCG Options
Selection: System Ref:      IntFix
    
```

2. [+/-]

```

Setup: TCG Options
Selection: System Ref:      ExtVid
    
```

Select the system reference required.

3. [SETUP]

Exit Setup mode.

**Time Code Generator Setup**

The Micro Lynx time code generator is used to set the system code type and frame rate. The options are set according to the type of work you are doing. If you are working with NTSC video, set the system code to 29.97 Hz/30. Consult the Micro Lynx Manual for more detailed description of the code types and rate options.

**Setting Time Code Generator System Speed/Code Type**

Set the required frame rate and code type in the Micro Lynx TCG Setup options menu. When Mediasound is in Chase mode, it automatically detects and adjusts to this setting.

**Procedure**

1. [SETUP], [TCG]

```

Setup: TCG Options
Selection: System Ref:      IntFix
    
```

Select time code generator setup.

2. [LAST/NEXT]

```

Setup: TCG Options
Selection: System Spd/Code: 29.97 Hz/30
    
```

Select system Speed/Code option.

3. [+/-]

Select the frame rate and code type. These options should be the same as the code type and rate you want to use in Mediasound.

4. [SETUP]

Exit Setup mode.

## Setting Time Code Generator Mode

You also need to set the generator mode in Micro Lynx TCG Setup options menu. This setting ensures that time code will be transmitted to Mediasound when the attached video transport is jogging or shuttling.

### Procedure

1. [SETUP], [TCG]

```
Setup: TCG Options
Selection: System Ref:      IntFix
```

Select time code generator setup.

2. [LAST/NEXT]

```
Setup: TCG Options
Selection: TCG Group Mode: Play, Mute
```

Select the Group Mode option.

3. [+/-]

```
Setup: TCG Options
Selection: TCG Group Mode: Play, Wind
```

Select the Play/Wind mode.

4. [SETUP]

Exit Setup mode.

**Note:** The Micro Lynx remembers the settings you programmed. After powering down, you do not need to repeat the setup steps every time you use the system.

## Micro Lynx Operation

### Controlling Mediasound with the Micro Lynx

1. Put Mediasound into Chase mode by clicking the Chase button in the Group Display Area.
2. On the Micro Lynx press [SOLO], then the [TCG] group select key.
3. Use the Micro Lynx calculator keypad to enter the program start time and press [STORE] [TIME] to enter a TCG start time.
4. Pressing the [PLAY] key starts the Micro Lynx time code generator (TCG) and transmits MIDI time code for Mediasound to chase.

## Controlling One Transport Device with the Micro Lynx

1. With all of the hardware powered down, connect a machine control cable and a time code cable between the Micro Lynx and the deck you want to control. The machine control cable goes from the Micro Lynx's Transport 1 connector to the deck's remote control input. The time code cable goes from the deck to the RDR 1 input on the Micro Lynx.
2. Connect a video sync source to the Video Ref port on the Micro Lynx and to the video machine you are controlling. If you do not have an external video sync source, connect the Micro Lynx Video Ref port to the VTR ref input and see step 6 below. Analog audio tape transports do not require the video sync connection.
3. Turn on the Micro Lynx.
4. On the Micro Lynx Keyboard, the group select keys will flash. Press machine key [A].
5. Next, you need to specify the type of machine you are using. Enter setup mode by pressing the [SETUP] key on the Micro Lynx keyboard. Press the [TRAN] key to select the type of machine you are going to synchronize. Use the [Next/Last] and [+/-] keys to select the correct type of machine from the menu.  
**Note:** If your deck does not appear in the menu, refer to the Micro Lynx Manual Appendix, Table 2, for alternate choices.
6. The Micro Lynx has an internal video sync source. If you did not connect an external video sync source in step 2, press the [TCG] key and use the [Next/Last] and [+/-] keys to set the System Ref option to IntFix and the Video Sync Gen option to On.
7. Press the [SETUP] key to leave setup mode.
8. You are now ready to synchronize the Transport to Mediasound.
9. Put Mediasound into Chase mode by clicking the Chase button in the Group Display Area.
10. On the Micro Lynx, press and hold the [Group] key and press the [A] and [TCG] group select keys. This forms a group of the Transport and Mediasound.
11. Press [PLAY]. The Transport and Mediasound will play and synchronize.

12. The Micro Lynx generator will always jam to the incoming reader code. The time code generator operation mode should be set to Play/Wind to follow group transport operation. Refer to TCG Option Menu in the Keyboard Controller section of the Micro Lynx Manual for option setting choices.

**Note:** When the TCG is put in the group or put into play, MTC will be transmitted from the selected, MIDI I/F or MAC connectors.

## Chapter 10 Option Cards

---

The Micro Lynx has been designed to quickly and easily accommodate four option cards to expand the Micro Lynx synchronizer capabilities.

This chapter describes the following option cards:

- **Video Sync Generator Card (VSG)**  
The VSG Card is a small daughter card that plugs directly into the mother board and generates Video Sync in NTSC or PAL. The video signal is referenced to the Micro Lynx system speed reference.
- **Third Machine Card (M3)**  
The M3 Card, plugs into a Micro Lynx expansion slot, permitting control of a third machine. The M3 Card also has the special hardware required to operate the Sony VO-5800 and VO-5850.
- **Digital Audio Clock Generator Card (ACG)**  
The Digital Audio Clock Generator Card plugs into a Micro Lynx expansion slot and is used to generate digital audio sample rate clocks. The digital audio signals can be used to lock a digital audio workstation or digital tape transport to the Micro Lynx system.
- **VITC Reader Card (VITC)**  
The VITC Card is a state-of-the-art, microprocessor based Vertical Interval Time Code (VITC) reader that plays into a Micro Lynx expansion slot. The VITC Card integrates directly with the Micro Lynx machine controllers and provides VITC reading capability when the VTR or VCR is not equipped to supply serial time code to the synchronizer.

## Video Sync Generator (VSG) Card

The Video Sync Generator Card generates composite video sync in NTSC or PAL. The VSG Card is a small daughter card that plugs directly into the mother board and generates Video Sync in NTSC or PAL. The video signal is referenced to the Micro Lynx system speed reference.

### Installation Procedure

1. Turn off the power and place the Micro Lynx System Unit on a static safe workstation. Ground yourself and the workstation anti-static mat.
2. Remove the six phillips screws securing the top cover of the System Unit.
3. Position the System Unit so that the front panel faces you, and remove the cover.
4. Locate connector J1, the Video Sync Generator 20-pin plug, in the right front corner of the main board.
5. Hold the VSG Card component side up and position socket J1 so that it can be placed into the J1 plug on the main board. Align the two standoffs on the main board with the holes in the VSG Card.

---

**Warning:**

**CAREFULLY** align the male and female connectors together. See Detail "B" in Figure 1. Insert all pins into the appropriate holes, failure to do so will **DESTROY** the VSG Card.

---

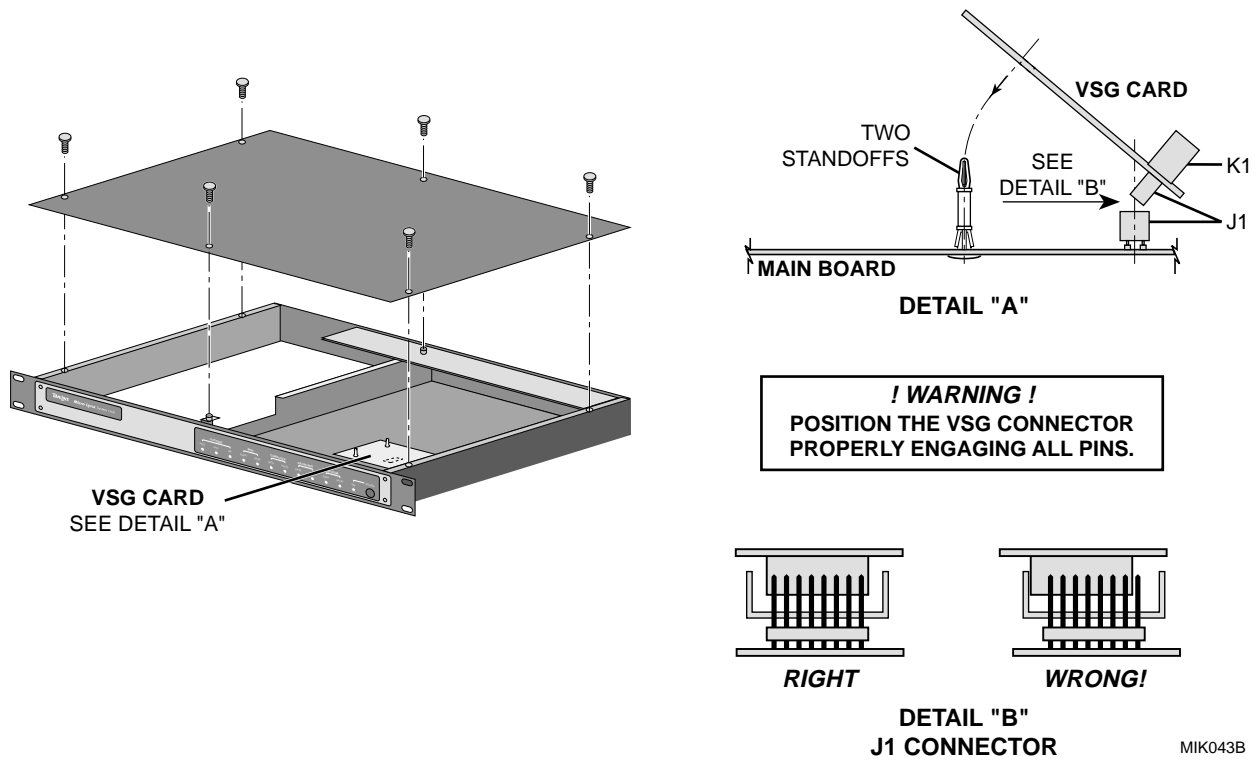

**Figure Chapter 10 -1. Video Sync Generator Card**

6. Press connector J1 and the standoffs into place.
7. Replace the top cover and the six phillips screws. Power up the unit. The Micro Lynx will recognize the VSG Card on power up. To turn the VSG on, press [SETUP], [TCG], [6], then [+]. Press [SETUP] again to return to the normal display.

## M3 Option Card

The Third Machine Card (M3) expands the standard two machine Micro Lynx to a three machine system, which permits more complex multiple transport control. The M3 Card supports the same transports as the two machine Micro Lynx main board machine controller.

The M3 Card also provides special hardware support for the Sony VO-5800 and the VO-5850. This is the ONLY port that may be used to connect a Sony VO-5850 to the Micro Lynx system.

Micro Lynx automatically detects the presence of the M3 Card, there are no user configuration changes to make. Plug in the card and select the transport type that you want to control.

On power up the Micro Lynx System Unit turns on the M3 LED in the option section of the front panel. This LED indicates that the M3 Card is installed and communicating correctly.

## Transport Options

Once the M3 Card is installed and initialized for a transport, there are several options that may be customized. Many of the default parameters listed below are automatically selected by the transport. However, by pressing [SETUP], [TRAN], then [TRAN] you may change the settings. A description of each item that may be selected follows the table. For operating information, please refer to the Micro Lynx Operating Manual, in particular the Keyboard Controller chapter.

Table Chapter 10 -1. TRAN Setup Options

KEY	MENU	SUB-MENU	RANGE
TRAN	Machine Select Last/Next +/- TRAN		
		Transport Mfg.	
		Machine Model	
		0 Capstan Mode	Wild, <i>Resolved</i>
		1 Capst Spd Trim	-128 to +127 (0)
		2 Lifter Defeat	Never, Normal, Not Stp/Play, Always
		3 Record In	Pulse Rec; P-Rec, Play
		4 Record Out	Pulse Play; P-Rec, Play; Pulse Stop; P-Rec, Stop; P-Play, Stop; Pulse Opto; Special Opto
		5 Rehearse In	Latch Reh; Pulse Reh; P-Reh, Play; P-Reh, Reclog; L-Reh, Reclog; Pulse Rec
		6 Rehearse Out	Unlatch Reh, Pulse Play, Save as Rec
		7 Approach Speed	20-254
		8 Bandwidth Limit	Off, On
		9 Reader Mode	LTC/SER TC; LTC/TT1; Serial TC; T.Timer 1
		00 Mute Control	Normal, Until Rslvd, Until Locked, Not Locked
		NEXT Lock Threshold	0-50 (35)
NEXT Lock Delay	0-50 (10)		
NEXT Park Window	0-10 (10)		

**Capstan Mode Resolved:** The Micro Lynx controls the speed of the machines capstan. It is used when synchronizing.

**Wild:** The machine capstan is set to its own internal reference and the Micro Lynx does not control its speed. Use it when striping time code or if the tape has no time code.

**Capstan Speed Trim** This advanced feature should be used only by an experienced engineer or technician. It allows the “wild speed” of the machine to be adjusted by the operator, when a voltage controlled machine does not run at the right speed before synchronizing. It can also be used to adjust the wild speed of a tape that was recorded off pitch.

Capstan speed trim is separately retained in memory for each transport type. It is restored when the transport is selected. It is NOT erased when [CLR] + [TRAN] is pressed. It is only erased if a complete memory clear is performed ([CLR] + [SYS]).

**Reader Mode** Selects the time code source for the machine; it is normally set to LTC.

**Lifter Defeat** Selects the conditions when the Micro Lynx will defeat the machines lifters to read time code from the tape; it is usually set to Normal. In Normal, the Micro Lynx defeats the lifters only as the machine slows to park, to check that it has located correctly.

**Record In** Selects the command method or logic to put the machine into

record.

**Record Out** Selects the command method or logic to drop the machine out of record.

**Rehearse In** Selects the command method or logic to put the machine into rehearse.

**Rehearse Out** Selects the command method or logic to drop the machine out of rehearse.

**Approach Speed** Sets the approach speed or deceleration point for a machine as it slows to park. Use it to adjust machine performance if the park point is consistently over shot or under shot. Increase the value to slow the transport later. Decrease the value to slow the transport earlier.

**Bandwidth Limit** Selects a time code reader input (RDR) filter circuit that bandwidth limits the input time code signal frequency range. It is used when time code sources are noisy and is most commonly applicable to video machines.

**Lock Threshold** The time code window or threshold in subframes (0-50 sfr), which the machine has to be within before the lock delay starts running. The lock window setting can be adjusted when time-to-lock may be more critical than lock accuracy. This can be used to fix problems with unstable machines, bad or misframed time code or to cause a Digital or Video tape transport to release with a looser lock tolerance. The setting is used in conjunction with the Lock Delay setting.

**Lock Delay** The time in frames (0-50 fr) that the machine has to be continuously in the lock window, before it is considered that the transport is locked, and the Micro Lynx will show lock status. It should be noted that very short lock delays could result in the machine locking in the wrong place.

**Park Window** The park window in frames (0-10 fr), for video and film transports only. This is used to accurately cue a video transport to a specific location. If the park window is set to zero, then the transport will respond to a  $\pm 1$  frame locate. The video park window setting is set for all VTRs and is not reset when a different video machine is selected for that group (A-C).

## M3 Card Initialization Procedure

1. [SOLO], [C], [SETUP], [TRAN]

SETUP LED flashes  
 TRAN LED turns on  
 LAST LED turns on  
 NEXT LED turns on  
 + LED turns on  
 - LED turns on  
 C LED

```

Setup:  AUTO Serial TRANSPORT
Tran:
  
```

You may access the Setup menus at any time. Go to the transport selection menu. If the Transport Option selection menu was accessed last, press [TRAN] again to access the Transport selection menu.

2. [NEXT]

```

Setup:  Ampex ATR-100
Tran:
  
```

Using [NEXT] or [LAST] select the manufacturer of the machine connected to the 'C' (Transport 3) port. For this example select Ampex.

3. [+]

```

Setup:  Ampex ATR-124
Tran:
  
```

Press [+] and [-] to select your machine type. Refer to the table of machines supported, in the Appendix.

4. [SETUP]

```

SOLO:c .                c-10:00:00:00
                        Err: 0.-
  
```

Press [SETUP] to exit Setup mode. Alternatively select a different menu to modify.

**Table Chapter 10 -2. Troubleshooting the M3 Card**

<b>Situation</b>	<b>Solution</b>	<b>Conditions</b>
SU M3 LED fails to turn on or is flashing	Check the Keyboard to SU cable connection. Verify the card installation. Check insertion and seating of the option card cable and connector.	If you have installed upgraded software, also check PROM installation on the main board.
When you try to SOLO C, it is "Not Available" or "does not exist"	Press [CLR] and [SYS], then [ENTR] to clear and reset the System Unit.	
No time code	Verify that the insertion and wiring of the time code cable from the SU to the machine is correct. Verify that the machine cable is correctly inserted.	Time code must already be striped on the tape.
No machine control	Verify that the correct transport type is selected.	The different machine selections are listed in the Appendix of the Micro Lynx manual.

## Installation Instructions

**Note:** If your Micro Lynx System Unit Serial Number is 1024 or higher, you have new metal work. The new metal work does not require the Option Card Bracket. Please turn to the instructions for new metalwork later in this section for instructions on installing the M3 Card.

1. Turn off the power and place the Micro Lynx System Unit on a static safe workstation. Ground yourself and the workstation anti-static mat.
2. On the back of the System Unit, remove the cover labeled THIRD MACHINE EXPANSION.
3. Remove the six phillips screws securing the top cover to the System Unit.
4. Position the System Unit so that the front panel faces you and remove the top cover.

### Install the Option Card Bracket

5. The Back Panel PCB is located at the top back of the chassis, horizontal to the back panel. Remove the “L” shaped bracket supporting the Back Panel PCB by removing the phillips screws; one on the left side of the board and the other on the back panel, to the right of the SYSTEM TALLY connector. The bracket is no longer needed, keep the phillips screws.

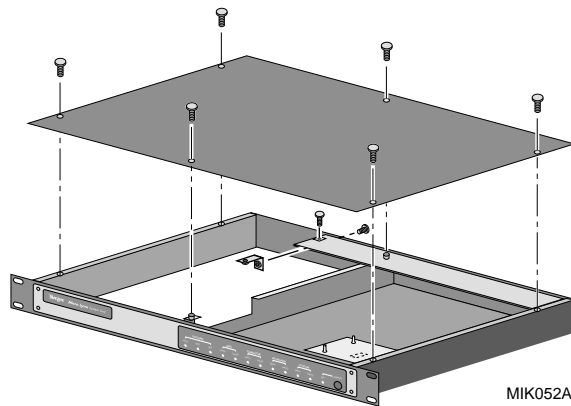
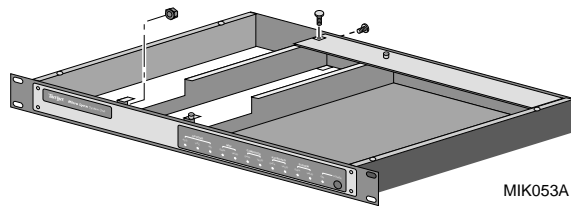

Figure Chapter 10 -2. Remove the Support Bracket

6. Hold the Option Card bracket so that the large cutout is face up. Set the front of the bracket in place on the threaded stud on the inside of the Front Panel. Set the bracket down and slide it under the left edge of the Back Panel PCB.

7. Insert and tighten the screws removed from the back panel, and from the Back Panel PCB. Place a nut on the threaded stud and secure the bracket to the front panel. (See Figure 10-3.)



**Figure Chapter 10 -3. Install the Option Card Bracket**

- Install the M3 Card**
8. The M3 Card is mounted on the left side of the System Unit, component side up.
  9. If you have the ACG Card already installed, remove the card from the bracket before installing the M3 Card.
  10. Tilt and slide the left side of the card into the groove along the bottom of the Micro Lynx Side Panel.
  11. As the card slides into the groove, lie it flat in the chassis.

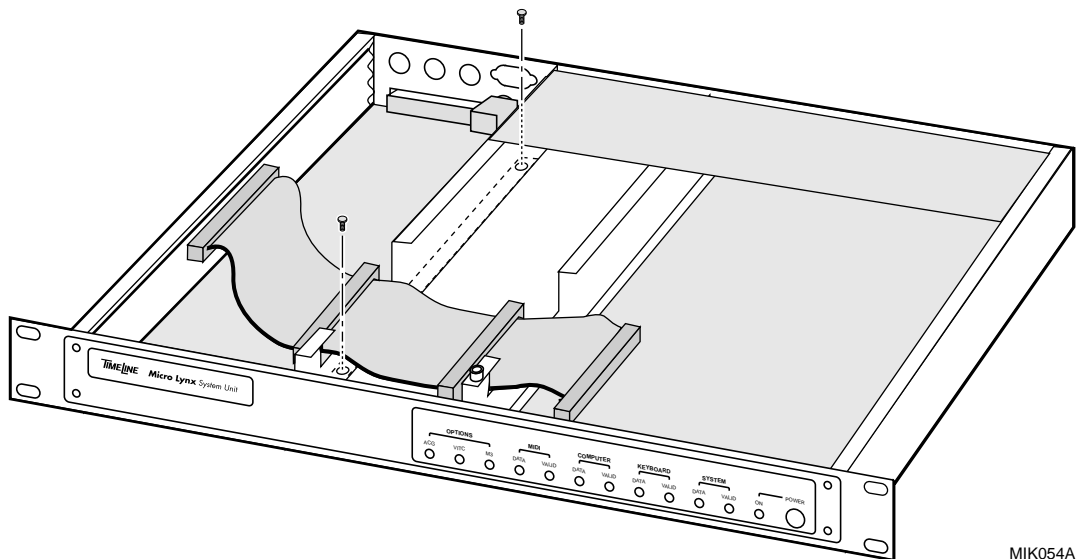

**Figure Chapter 10 -4. Installation of M3 Card**

12. Slide the M3 Card against the back panel so that the TRANSPORT connector and RDR jack are seated in the appropriate cutouts in the back panel.
13. Insert two phillips screws through the M3 Card, into the option card bracket standoffs and tighten.
14. If the ACG Card was removed, reinstall the card.

15. Insert the second connector of the Option Card Cable into J1 on the M3 Card and connect the other end of the cable into J3 on the Main Board. The unused connectors will lie in the open area in the System Unit, unless you have option cards installed.
16. Replace the top cover and the six phillips screws.
17. Connect the transport cable and reader cables between the Micro Lynx and third transport.
18. Power up the System Unit. The M3 LED on the System Unit OPTION Section should turn on.
19. Press [SETUP], [TRAN], [C], to select the type of transport to control.

**Install the M3 Option Card (New Metal Work)**

1. Turn off the power and place the Micro Lynx System Unit on a static safe workstation. Ground yourself and the workstation anti-static mat.
2. On the back of the System Unit, remove the cover labeled THIRD MACHINE EXPANSION.
3. Remove the six phillips screws securing the top cover to the System Unit.
4. Position the System Unit so that the front panel faces you and remove the top cover.
5. The M3 Card is mounted on the left side of the System Unit, component side up. The M3 Card will lie flat in the chassis.
6. If you have the ACG Card already installed, remove the card from the bracket before installing the M3 Card.
7. Slide the M3 Card against the back panel so that the TRANSPORT connector and RDR jack are seated in the appropriate cutouts in the back panel.

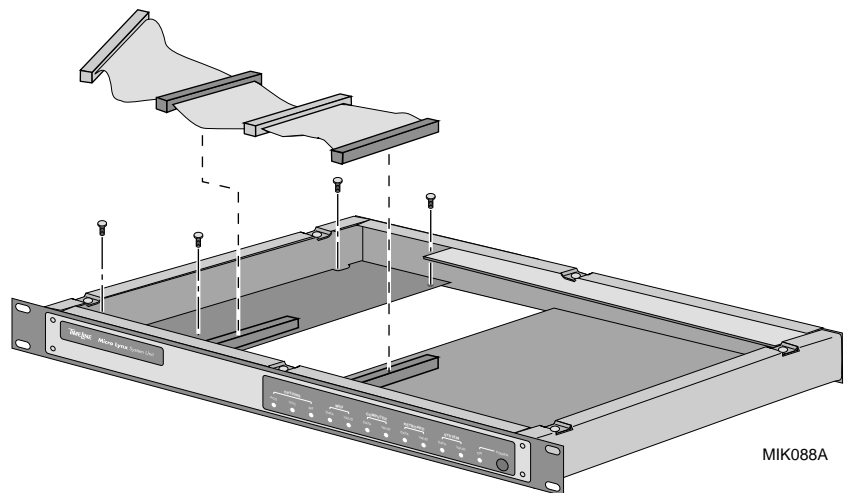

Figure Chapter 10 -5. Installation of M3 Card

8. Insert four phillips screws through the M3 Card, into the chassis, and tighten. (See Figure 10-5.)
9. If the ACG Card was removed, reinstall the card.
10. Insert the second connector of the Option Card Cable into J1 on the M3 Card and connect the other end of the cable into J3 on the Main Board. The unused connectors will lie in the open area in the System Unit, unless you have option cards installed.
11. Replace the top cover and the six phillips screws.
12. Connect the transport cable and reader cables between the Micro Lynx and third transport.
13. Power up the System Unit. The M3 LED on the System Unit OPTION Section will turn on.
14. Press [SETUP], [TRAN], [C], to select the type of transport to control.

## Digital Audio Clock Generator Card (ACG)

The Digital Audio Clock Generator (ACG) is the first synchronizer product developed, in a new class of interface products, which bridge the worlds of digital audio, time code, and machine control.

In a conventional machine environment, true synchronization of digital audio transports and workstations requires special reference clocks that are at a constant ratio to the system frame rate.

Even machines with internal time code readers and the ability to locate to specific time code locations require an exact sample rate or speed reference. Without this reference, the machines will slowly drift apart.

There are two ACG configurations:

- ACG-1 with Word Clock and
- Oversample Clock outputs

ACG-2 same as ACG-1 features and adds AES/EBU Silent Output and AES/EBU Clock Inputs, which can be used as the Micro Lynx system reference.

### Speed Reference

Speed reference is an essential component for synchronizing any system. For a Digital/Audio Workstation or digital tape machine to stay in sync with other time code based equipment, a “common” synchronizing speed reference is required. Normally a fixed rate reference like video sync or sample rate clock (word clock) is used.

Frequently a fixed rate speed reference is not available, not accepted by all of the equipment in the system, or may need to be varied to satisfy production requirements.

### The ACG Solution

The TimeLine ACG Card provides a solution to this problem by offering both fixed and variable digital audio speed reference generation that is always locked to the system frame rate.

There are two ACG Card configurations available for the Micro Lynx, both of which convert the synchronizer system into a powerful problem solver in the world of digital audio.

Applications for the ACG Card include:

- Transferring, recording or playing any piece of digital audio synchronously.
- Varispeeding a digital audio workstation or transport.
- Running a workstation at a non-standard sample rate.
- Locking two digital transports together at different rates.

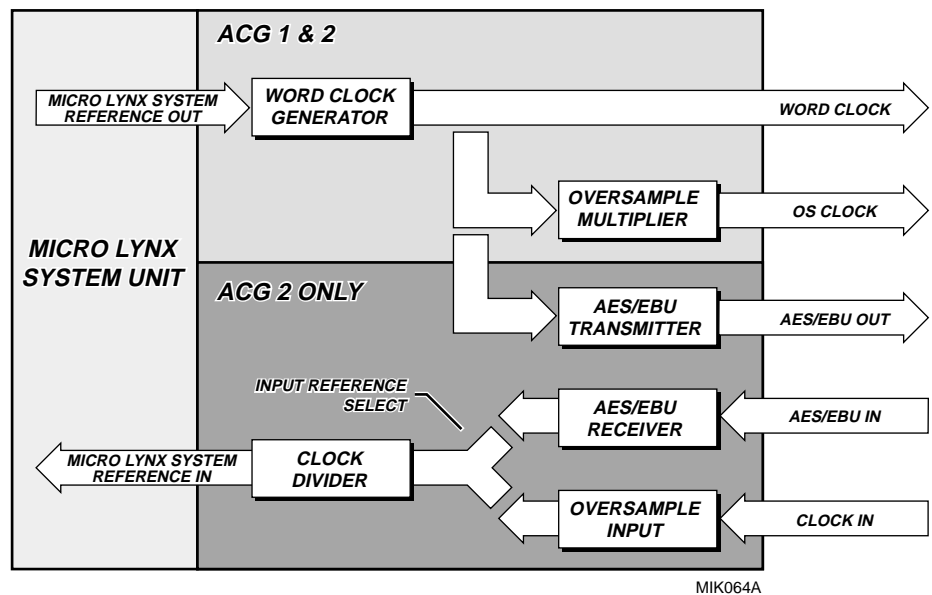

Figure Chapter 10 -6. ACG Block Diagram

## ACG-1 Features

- Generates stable word and oversample clock outputs that are phase locked to the Micro Lynx system reference.
- Clock outputs can be locked to the system reference at a number of fixed Sample Rate Ratios (SRR).
- Clock outputs can be varied from the nominal output sample rate (varispeed) in .01% steps.
- Four selectable standard oversample output clock multipliers.
- Clock output will track incoming varispeed time code with zero drift or error.

## ACG-2 Features

ACG-2 includes the ACG-1 features and adds the following:

- Reads incoming word clock, oversample clock, or AES/EBU bit stream.
- Generates phase-locked silent AES/EBU bit stream.
- Incoming digital audio signal can be used as Micro Lynx system reference.
- Has independent input and output sample rate ratio selections. This can be used, for example, to lock a 44.1K tape in a system with a 48K tape.
- The input clock rate can be varied (in 0.01% steps) to allow offspeed devices or program material to be correctly synchronized.

**Sample Rate Ratio** A Sample Rate Ratio (SRR) is the number of digital audio samples-per-frame. Instead of the actual sample rate, which tends to be an unwieldy number, the Micro Lynx LEDs indicate the constant ratio or SRR and if applicable, the ratio modifier.

$$\text{Sample rate} / \text{Frame rate} = \text{Sample rate ratio}$$

For example, at a nominal sample rate of 48.000 KHz and a frame rate of 30 Hz, the SRR is 1600. At 25 Hz, the SRR is 1920. The Micro Lynx LED indicators show selected sample rate ratio.

If the system frame rate increases or decreases (speed, not code type) then the actual sample rate will increase or decrease to an unknown (not very useful) number. However, as both frame rate and sample rate change together, the SRR stays constant.

Table 10-2 shows the actual sample rate ratios generated by the ACG Card.

**Table Chapter 10 -3. ACG Card Sample Rate Ratios**

Sample Rate (Ks/s)	FRAME RATE (fps)			
	30	29.97	25	24
48.000	1600.00	1601.60	1920.00	2000.00
47.952	1598.40	1600.00	1918.08	1998.00
44.100	1470.00	1471.47	1764.00	1837.50
44.056	1468.53	1470.00	1762.23	1835.66
32.000	1066.66	1067.73	1280.00	1333.33

---

## Operation

The ACG Card once installed is active all the time. The ACG setup configuration can be adjusted during any Micro Lynx operation without affecting the current operation since the ACG Card processor operates independently from the other Micro Lynx functions. The Keyboard ACG LED will light to indicate that the ACG Card is installed.

Ratios on both ACG Cards can be configured by the operator using the Micro Lynx Setup menus. All of the known fixed ratios are supported and the Card will automatically generate the standard pull ups and pull downs.

For example if you are working with NTSC video at a frame rate of 29.97, the ACG Card can supply either 48,000 or 47,952 samples per second, dependent on the application.

Additionally the number of samples-per-frame can be set to any non-standard ratio to allow for those situations where it is necessary to run a digital system "off speed" for it to play back in sync.

Use the ACG variable ratio in and out to generate double pull up or pull downs if these are required to correct previous transfer errors.

**Off-Tape Time Code** The ACG Card is always locked to the Micro Lynx system (speed) reference. If the speed reference is set to VSO (variable speed,  $\pm 12.5\%$ ), then the ACG Card will lock to off tape code. The ACG Card will generate stabilized digital audio clocks with the selected SRR that are referenced to the incoming frame rate of the Master machine time code with 0.000% drift or error.

## Setup Options

Access to the Setup Options is available after the ACG Card is installed. Press [SETUP] then [ACG] to access the option menu. If the ACG menu is not displayed then verify the ACG Card installation.

**Table Chapter 10 -4. ACG Setup Options**

KEY	MENU	SUB-MENU	RANGE
ACG	ACG Option	0 Nom S/Rate Out	32.000, 44.056, 44.100, 47.952, 48.000 Ks/s
		1 Var Ratio Out	Off, On
		2 Var Ratio Out %	85% - 115% (100.00%)
		3 Oversample Out	128, 192, 256, 384
		4 Nom S/Rate In	32.000, 44.056, 44.100, 47.952, 48.000 Ks/s
		5 Var Ratio In	Off, On
		6 Var Ratio In %	87.5% - 112.5% (100.00%)
		7 Oversample In	128, 192, 256, 384, Off
		8 Reference In	AES/EBU, Clock In BNC

**Nominal Sample Rate Out & In** Used to select the nominal sample rate output and input at the selected system frame rate. The output may be different from the input.

**Var Ratio Out & In** Used to select a variable output or input sample rate ratio. When set to off, the system uses the selected nominal sample rates.

**Var Ratio Out & In %** If variable ratio is selected, is used to vary the output or input sample rate with respect to the system reference frame rate (speed). The ACG Card gives a “not locked” error message if the cumulative system speed change exceeds the ACG output range. You can use the Micro Lynx Keyboard Jog Wheel or the [+] and [-] keys to adjust the ratio.

**Oversample Variable Out & In** Used to select the oversample output multiplier or input clock divider. Oversample In must be set to off if word clock is used as the input signal. Oversample ratios can be set to one of four standard ratios.

**Reference In** Used to select either the AES/EBU or TTL BNC clock input that will be used if the ACG is selected as the system speed reference source in the TCG Option menu. The Clock In BNC connector can be used for Word Clock or Oversample Clock. Use menu item ‘7’ to select Word Clock or the required Oversample modifier.

## Digital Audio Clock Generator LEDs

The Digital Audio Clock Generator LEDs located on the Micro Lynx Keyboard Controller indicate the ACG Card status. The LEDs directly reflect the parameters that have been set in the ACG options under the Setup menu. There are two rows of LEDs the upper row is for ACG inputs and the lower row is for ACG outputs.

- IN 1600/1920** This LED indicates that an ACG input sample rate ratio of either 1600 samples-per-frame at 30 Hz or 1920 samples-per-frame at 25 Hz has been set. This is a nominal sample rate of 48,000 Ks/s. This LED should be read in conjunction with the NON STD and +/- LEDs. If this LED flashes, it indicates that the ACG Card has not locked to the incoming signal.
- OUT 1600/1920** This LED indicates that an ACG output sample rate ratio of either 1600 samples-per-frame at 30 Hz or 1920 samples-per-frame at 25 Hz has been set. This is a nominal sample rate of 48,000 Ks/s. This LED should be read in conjunction with the NON STD and +/- LEDs. If this LED flashes, it indicates that the ACG output is not locked.
- IN 1470/1764** This LED indicates that an ACG input sample rate ratio of either 1470 samples-per-frame at 30 Hz or 1764 samples-per-frame at 25 Hz has been set. This is a nominal sample rate of 44,100 Ks/s. This LED should be read in conjunction with the NON STD and +/- LEDs. If this LED flashes, it indicates that the ACG Card has not locked to the incoming signal.
- OUT 1470/1764** This LED indicates that an ACG output sample rate ratio of either 1470 samples-per-frame at 30 Hz or 1764 samples-per-frame at 25 Hz has been set. This is a nominal sample rate of 44,100 Ks/s. This LED should be read in conjunction with the NON STD and +/- LEDs. If this LED flashes, it indicates that the ACG output is not locked.
- NON STD IN** If only this LED is on, it indicates that an ACG input sample rate ratio of either 1066 2/3 samples-per-frame at 30 Hz or 1280 samples-per-frame at 25 Hz has been set. This is a nominal sample rate of 32,000 Ks/s. If this LED flashes, it indicates that the ACG Card has not locked to the incoming signal. If the LED is on in combination with one of the previous two input LEDs, it indicates that the selected nominal sample rate ratio is being varied. There is no specific indication when a 32,000 Ks/s input is being varied.

**NON STD OUT** If only this LED is on it indicates that an ACG output sample rate ratio of either 1066 2/3 samples-per-frame at 30 Hz or 1280 samples-per-frame at 25 Hz has been set. This is a nominal sample rate of 32,000 Ks/s. If this LED flashes it indicates that the ACG output is not locked.

If the LED is on in combination with one of the previous two output LEDs, it indicates that the selected nominal sample rate ratio is being varied. There is no specific indication when a 32,000 Ks/s output is being varied.

**+ / – IN** This LED operates in combination with the previous input LEDs and indicates that the selected input sample rate ratio has been automatically pulled up or down by 0.1%; for example, from 48,000 to 47,952 or from 44.100 to 44,056.

When the nominal sample rate is selected, the ACG Card will automatically adjust the sample rate ratio by +0.1% if the sample rate requested requires a pull up because the system frame rate is running at 29.97 Hz instead of 30/25/24 Hz. Or, it will automatically adjust the sample rate ratio by -0.1% if the sample rate requires a pull down because the system frame rate is running at 30/25/24 Hz instead of 29.97 Hz.

**+ / – OUT** This LED operates in combination with the previous output LEDs. It indicates that the selected output sample rate ratio has been automatically pulled up or down by 0.1%; for example from 48,000 to 47,952 or from 44.100 to 44,056.

When the nominal sample rate is selected, the ACG Card will automatically adjust the sample rate ratio by +0.1% if the sample rate requested requires a pull up because the system frame rate is running at 29.97 Hz instead of 30/25/24 Hz. Or it will automatically adjust the sample rate ratio by -0.1% if the sample rate requires a pull down because the system frame rate is running at 30/25/24 Hz instead of 29.97 Hz.

## Audio Clock Generator Outputs

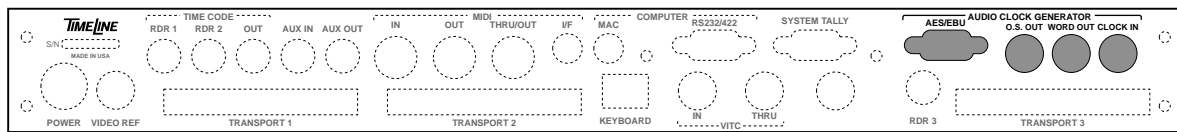

MIK017B

Figure Chapter 10 -7. Audio Clock Generator Inputs/Outputs

**ACG-1 Outputs** The ACG-1 Card uses the WORD OUT and O.S. OUT jacks on the back of the System Unit. The other ports and jacks in the Audio Clock Generator section are not installed.

**O.S. OUT.** BNC, +5V TTL level output. The Oversample Clock Output is locked to the system reference with a frequency determined by the word clock rate and the oversample output multiplier.

**WORD OUT.** BNC, +5V TTL level output. The Word Clock Out is locked to the system reference with either a fixed or variable ratio to the nominal sample rate.

**ACG-2 Outputs/Inputs** All connectors and jacks in the Audio Clock Generator section on the back of the System Unit are installed.

**AES/EBU.** 9-pin 'D' socket, transformer coupled, digital input and output connector. It will output a silent AES/EBU bit stream locked to the system reference with either a fixed or variable ratio to the nominal sample rate. It will also accept an AES/EBU input that can be used as a system reference.

Table Chapter 10 -5. AES/EBU Connector Pin Description

Pin	Description
1	Ground
2	AES/EBU In-
3	Ground
4	AES/EBU Out-
5	Ground
6	AES/EBU In+
7	Ground
8	Ground
9	AES/EBU Out+

**O.S. OUT.** BNC, +5V TTL level output. The Oversample Clock Output is locked to the system reference with a frequency determined by the word clock rate and the oversample output multiplier.

**WORD OUT.** BNC, +5V TTL level output. The Word Clock Out is locked to the system reference with either a fixed or variable ratio to the nominal sample rate.

**CLOCK IN.** BNC, +5V TTL level input. The Digital Audio Word Clock or Oversample Clock input is used with the oversample input divider to provide a system speed reference. This connector is also used to input word clock. If word clock is used as the system reference, then the Oversample divider should be set to off.

## ACG Card Setup

### Procedure

Hold the "GRP" key, and add groups in order of priority

Power on the SU and KBD.

1. [SETUP], [ACG]
  - SETUP LED flashes*
  - ACG LED turns on*
  - LAST LED turns on*
  - NEXT LED turns on*
  - + LED turns on*
  - LED turns on*

Setup: ACG Options  
Selection: Nom S/Rate Out: 48.00 Ks/s

You may access the Setup menu at any time.

2. [+]

Setup: ACG Options  
Selection: Nom S/Rate Out: 47.592 Ks/s

Press the [+] and [-] keys to select the options in each menu selection. Use [NEXT] and [LAST] to step through menu items.

**Table Chapter 10 -6. Troubleshooting the ACG Card**

<b>Situation</b>	<b>Solution</b>	<b>Conditions</b>
SU ACG LED fails to turn on or it is flashing	Verify the card installation. Check insertion and seating of the option card cable and connector.	If you have installed upgraded software, also check PROM installation on the main board.
ACG not available when selected	Use [CLR] + [SYS] to reset the SU	Check the new PROM installation on the Main board.

## Error Conditions

**Warning** If any of the following LEDs are flashing it indicates that the ACG output is not locked to the respective Micro Lynx system reference or input.

IN 1600/1920  
OUT 1600/1920  
IN 1470/1764  
OUT 1470/1764  
NON STD

**System Error** When the display reads:

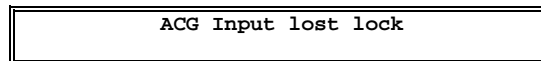
A rectangular display box with a double-line border containing the text "ACG Input lost lock".

it indicates that the ACG Card has not locked to the incoming signal because the signal is out of range, can't lock, or no signal is present.

When the display reads:

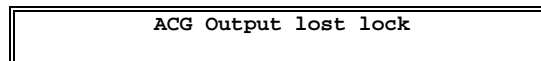
A rectangular display box with a double-line border containing the text "ACG Output lost lock".

it indicates that the ACG Card has not locked to the signal because it is out of range, can't lock, or no signal is present.

## Installation Instructions

**Note:** If your Micro Lynx System Unit Serial Number is 1024 or higher, you have new metal work. Please turn to instructions with new metalwork later in this section for instructions on installing the ACG Card.

1. Turn off the power and place the Micro Lynx System Unit on a static safe workstation. Ground yourself and the workstation anti-static mat.
2. On the back of the System Unit, remove the cover labeled AUDIO CLOCK GENERATOR.
3. Remove the six phillips screws securing the top cover to the System Unit.
4. Position the System Unit so that the front panel faces you, and remove the top cover.

**Install the Option Card Bracket**

5. The Back Panel PCB is located at the top back of the chassis, horizontal to the back panel. Remove the “L” shaped bracket supporting the Back Panel PCB by removing the phillips screws; one on the left side of the board and the other on the back panel, to the right of the SYSTEM TALLY connector. The bracket is no longer needed, keep the phillips screws.

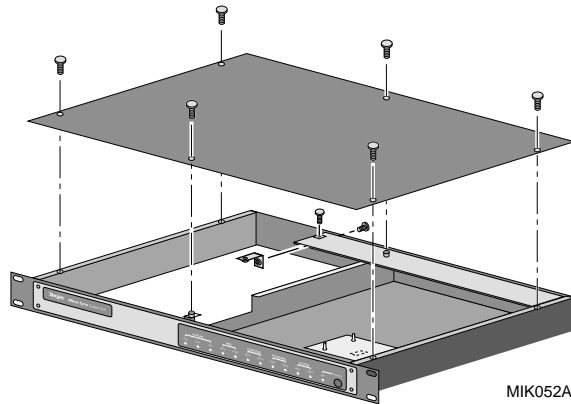

**Figure Chapter 10 -8. Remove Support Bracket**

6. Hold the Option Card bracket so that the large cutout is face up. Set the front of the bracket in place on the threaded stud on the inside of the front panel. Set the bracket down and slide it under the left edge of the Back Panel PCB.
7. Insert and tighten the screws removed from the back panel, and from the Back Panel PCB. Place a nut on the threaded stud and secure the bracket to the front panel. (See Figure 10-9.)

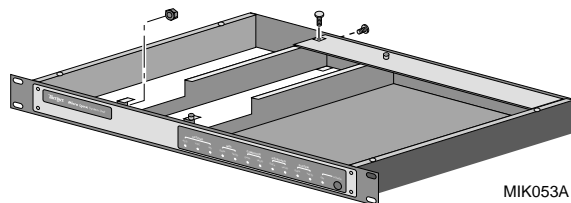
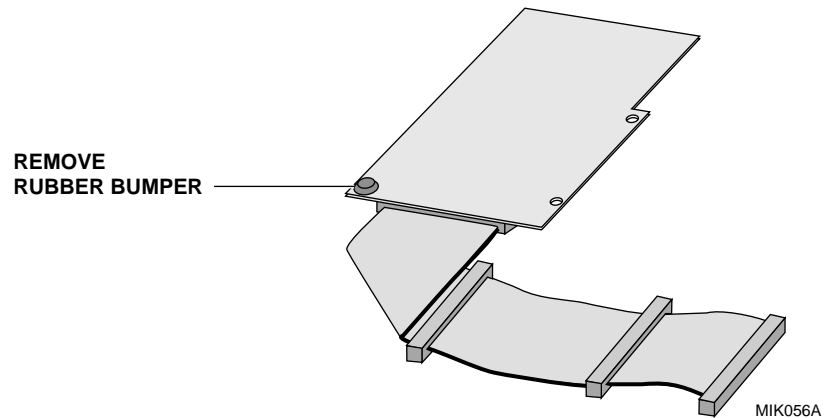

**Figure Chapter 10 -9. Install the Option Card Bracket**

**Install the ACG Option Card**

8. Locate and remove the black rubber bumper on the corner of the ACG Card. (See Figure 10-10.)
9. The ACG Card is mounted on the left side of the System Unit.
10. If you have the M3 Card or VITC Card already installed in the Micro Lynx, remove the Option Card cable before installing the ACG Card.

11. The Option Card Cable is a ribbon cable with four connectors attached. On one end of the cable, the second connector is about 3.5" from the end. Insert this end into connector J1 on the component side of the ACG Card. The connector should be attached so that the cable falls away from the ACG Card as illustrated in Figure 10-10.



**Figure Chapter 10 -10. Option Cable Installation**

12. Position the ACG Card component side down with connector J1 toward the front of the System Unit. Approximately 1.25" from the J1 connector, bend the Option Card cable under, so that it makes a right-angle turn (the unused connectors on the cable will face the chassis bottom), as shown in Figure 10-10.
13. Hold the folded Option Card cable over the cutout in the Option Card bracket, tilt and slide the left side of the card into the groove, along the top of the Micro Lynx Side Panel.
14. As the card slides into the groove, lie it flat on the Option Card bracket.
15. Slide the ACG Card against the back panel, so that the AES/EBU connector and the O.S. OUT, WORD OUT and CLOCK IN jacks are seated in the appropriate cutouts in the back panel. Insert the washers and nuts onto the BNC connectors.
16. Insert two phillips screws through the ACG Card into the Option Card bracket standoffs and tighten.
17. If the M3 Card is fitted, insert the Option Card cable connector into J1 on the M3 Card. If the VITC Card is fitted, insert the Option Card cable connector into J1 on the VITC Card.

18. Connect the other end of the cable into J3 on the Main Board. The unused connectors will lie in the open area in the middle of the System Unit, unless you have option cards installed.

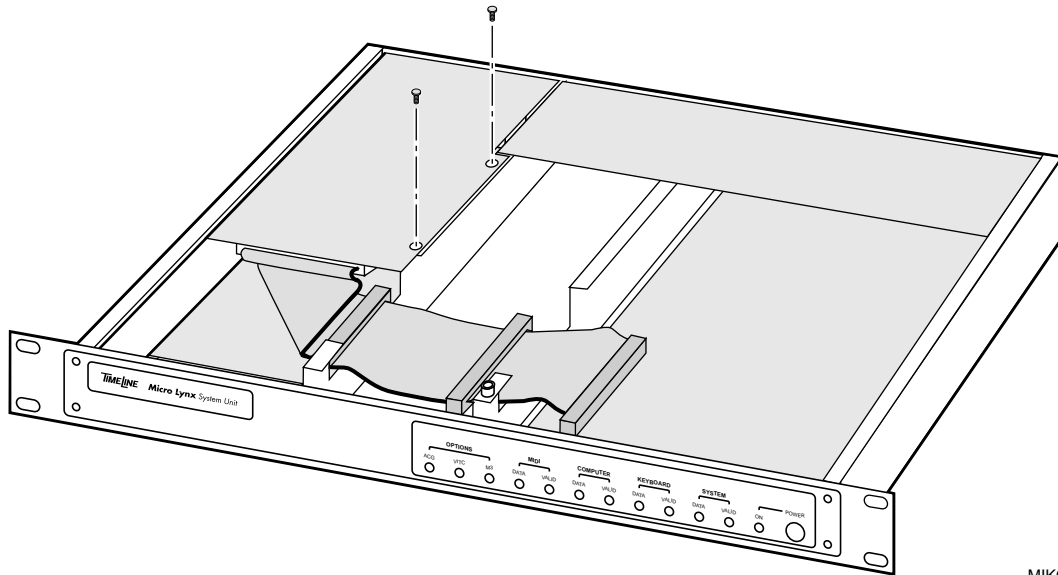

Figure Chapter 10 -11. Installation of the ACG Card

19. Replace the top cover and the six phillips screws.
20. Power up the System Unit. The Micro Lynx will recognize the ACG Card on power up and the ACG LED on the System Unit OPTION Section will turn on. Press [SETUP], [ACG], to configure the card functions.

**Install the ACG Option Card Bracket (With New Metal Work)**

1. Turn off the power and place the Micro Lynx System Unit on a static safe workstation. Ground yourself and the workstation anti-static mat.
2. On the back of the System Unit, remove the cover labeled AUDIO CLOCK GENERATOR.
3. Remove the six phillips screws securing the top cover to the System Unit.
4. Position the System Unit so that the front panel faces you, and remove the top cover.

- Remove the “L” shaped bracket supporting the Back Panel PCB. Relocate this bracket to the left side of the chassis as shown in Detail A and secure using the phillips screw supplied in the ACG Option Installation Kit. (See Figure 10-12.)

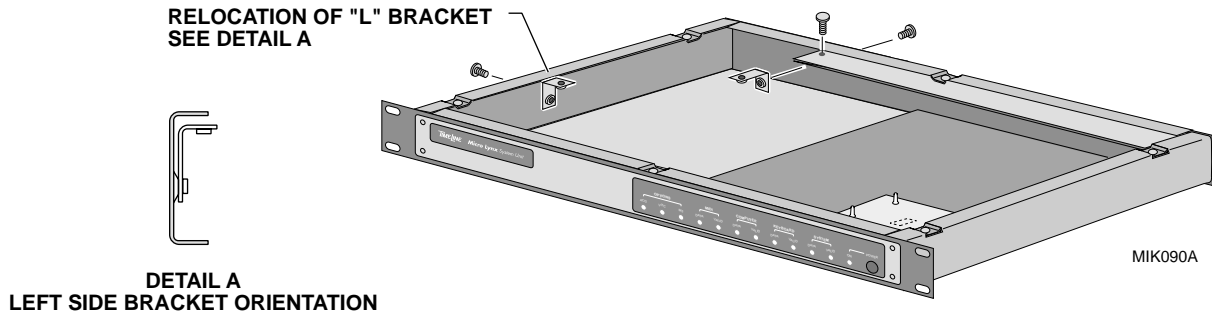

Figure Chapter 10 -12. Relocation of “L” Bracket

- Remove the M3 Card, if installed. Remove the nut on the left threaded stud securing the front panel to the chassis.
- Hold the ACG Option Card bracket diagonally across the chassis with the cable opening to the front. Set the front of the bracket in place on the threaded stud, inside the chassis. Slide the bracket under the left edge of the Back Panel PCB and the VITC Card (if installed).
- Insert and tighten the screw removed from the back panel, and from the Back Panel PCB. Replace the nut on the front panel threaded stud to secure the bracket. (See Figure 10-13.)

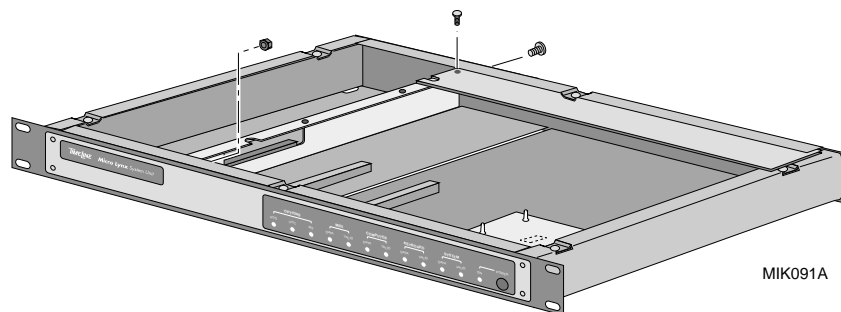
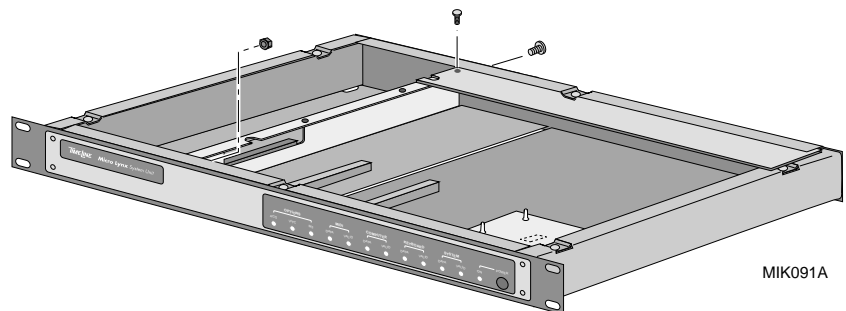

Figure Chapter 10 -13. Install the ACG Option Card Bracket

#### Install the ACG Option Card (With New Metal Work)

- Reinstall the M3 Card, if it was removed. The ACG Card is mounted on the left side of the System Unit, above the M3 Card.
- Remove the mounting standoffs from the 9-pin connector on the ACG Card.

11. The Option Card cable is a ribbon cable with four connectors attached. On one end of the cable, the second connector is about 3.5" from the end. Insert this end into connector J1 on the component side of the ACG Card. The connector should be attached so that the cable falls away from the ACG Card, as illustrated in Figure 10-10.
12. Position the ACG Card component side down with connector J1 toward the front of the System Unit. Approximately 1.25" from the J1 connector, bend the Option Card cable under, so that it makes a right-angle turn (the unused connectors on the cable will face the chassis bottom).
13. Insert the folded Option Card cable through the opening in the Option Card bracket.
14. Lie the ACG Card flat on the Option Card bracket. Slide the ACG Card against the back panel, so that the AES/EBU connector and the O.S. OUT, WORD OUT and CLOCK IN jacks are seated in the appropriate cutouts in the back panel. Insert the washers and nuts onto the BNC connectors. Replace the mounting standoffs on the 9-pin connector.
15. The corner of the ACG Card, with the black rubber bumper, will rest on the "L" bracket installed on the side of the chassis in Step 5. Insert two phillips screws through the ACG Card into the Option Card bracket and tighten. (See Figure 10-14.)



**Figure Chapter 10 -14. Install the ACG Card**

16. If the M3 Card is fitted, insert the Option Card cable connector into J1 on the M3 Card. If the VITC Card is fitted, insert the Option Card cable connector into J1 on the VITC Card.
17. Connect the other end of the cable into J3 on the Main Board. The unused connectors will lie in the open area in the middle of the System Unit, unless you have option cards installed.
18. Replace the top cover and the six phillips screws.
19. Power up the System Unit. The Micro Lynx will recognize the ACG Card on power up and the ACG LED on the System Unit OPTION Section will turn on. Press [SETUP], [ACG], to the configure the card functions.

---

## VITC Reader Card

### Features

- Automatic or manual line selections modes.
- Automatic switch between LTC and VITC at 1/3rd play speed.
- Allocation to any of the three Micro Lynx machines.
- Valid VITC code, type and line status display.

### Introduction

The Micro Lynx VITC Reader Card is a state-of-the-art, microprocessor based Vertical Interval Time Code (VITC) reader that installs inside the Micro Lynx system unit. The VITC Card integrates directly with any Micro Lynx machine controller, and eliminates the need for an external VITC to LTC translator.

The VITC Reader Card is used in audio-for-video post-production applications, when a VITC reading capability is required, and the VTR or VCR is not equipped to supply serial time code to the synchronizer.

Since VITC can be read in still mode and at very slow speeds, it can be used for accurately determining video tape position. The Micro Lynx seamlessly switches at 1/3rd play speed; between Longitudinal Time Code (LTC) and VITC, ensuring smooth operation and accurate time code values for use in dialog replacement, sound effects spotting and Foley applications. A Micro Lynx keyboard status LED indicates when VITC is present and the LCD displays when the Micro Lynx is using VITC to update the machine reader position.

VITC is a form of time code that is only used with video. It is recorded as part of the video signal in the vertical blanking interval. VITC uses a 90-bit time code data word that is recorded on two non-consecutive video lines, at the beginning of each video field.

The Micro Lynx keyboard provides a comprehensive use interface for selecting VITC parameters. A function key accesses the VITC menu setup options. The menu structure is used to freely allocate the VITC Card to any video transport, and to set the line scan mode. The scan mode can be automatic or fixed. In automatic, the Micro Lynx scans all video lines and will select the first available line pair with matching time codes. In fixed scan, the user specifies the lines for reading. The Keyboard shows a clear display of all lines present and lines selected to assist VITC reader configuration.

The VITC Option Card also updates the output of the time code and MIDI time code generators, in Jog, Shuttle and Still modes. This is particularly useful when using digital audio workstations that can read time code or MTC in still and slow motion modes. Specific applications include spotting sound effects and capturing frame accurate video positions.

The VITC Card is an essential addition to the Micro Lynx system for audio and video applications.

### Installation Instructions

**Note:** If your Micro Lynx System Unit Serial Number is 1024 or higher, you have new metal work. The new metal work does not require the Option Card Bracket. Please turn to the instructions for new metalwork later in this section for instruction on installing the VITC Card.

1. Turn off the power and place the Micro Lynx System Unit on a static safe workstation. Ground yourself and the workstation anti-static mat.
2. On the back of the System Unit, remove cover labeled VITC READER.
3. Remove the six phillips screws securing the top cover to the System Unit.
4. Position the System Unit so that the front panel faces you, and remove the top cover.

#### Install the Option Card Bracket

5. The Back Panel PCB is located at the top back of the chassis, horizontal to the back panel. Remove the "L" shaped bracket supporting the Back Panel PCB by removing the phillips screws; one on the left side of the board and the other on the back panel, to the right of the SYSTEM TALLY connector. The bracket is no longer needed, keep the phillips screws.

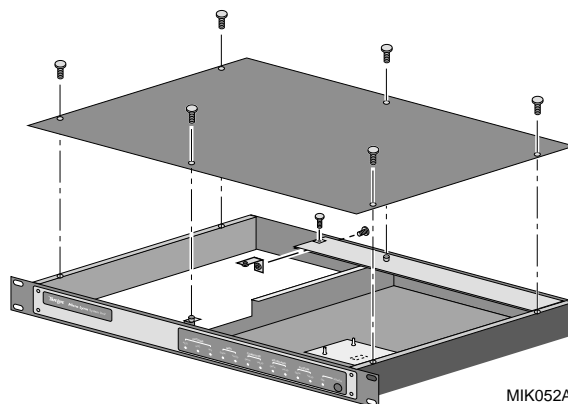

Figure Chapter 10 -15. Remove the Support Bracket

6. Hold the Option Card bracket so that the large cutout is face up. Set the front of the bracket in place on the threaded stud on the inside of the front panel. Set the bracket down and slide it under the left edge of the Back Panel PCB.
7. Insert and tighten the screws removed from the back panel, and from the Back Panel PCB. Place a nut on the threaded stud and secure the bracket to the front panel. (See Figure 10-16)

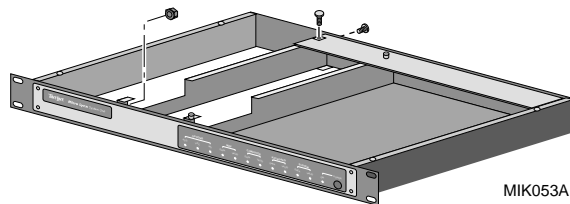

Figure Chapter 10 -16. Install the Option Card Bracket

### Install the VITC Option Card

8. The VITC Card is mounted to the right of the Option Card bracket, component side up.
9. If you have the M3 or ACG Card already installed in the Micro Lynx, remove the Option Card cable from J3 on the Main Board before installing the VITC Card.
10. Place the VITC Card under the lip on the mounting bracket and slide against the back panel so that the VITC IN and VITC THRU jacks are seated in the appropriate cutouts in the back panel. Insert the washers and nuts onto the BNC connectors.
11. Insert the three phillips screws through the VITC Card into the Option Card bracket, as show in Figure 10-17, and tighten.

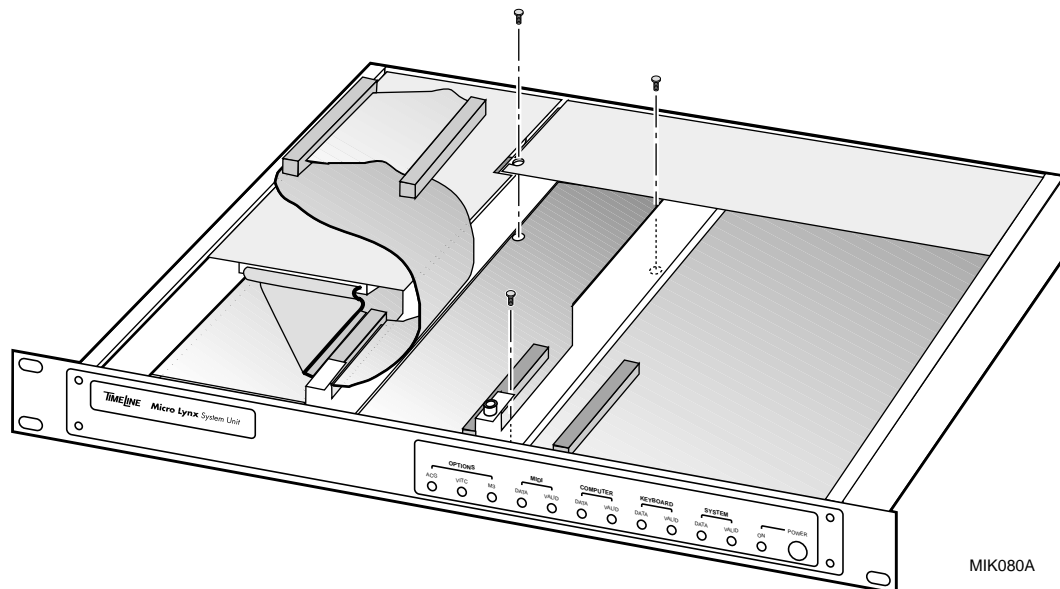
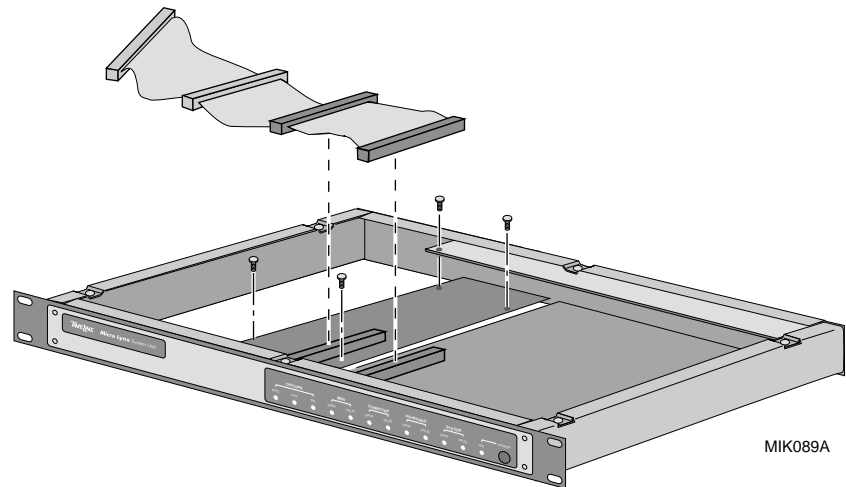

Figure Chapter 10 -17. Securing the VITC Card

12. Insert the Option Card cable connector into J1 on the VITC board.
13. Connect the end of the cable into J3 on the Main Board. The unused connectors on the left of the cable will lie in the open area, unless you have option cards installed.
14. Replace the top cover and the six phillips screws.
15. Power up the System Unit. The Micro Lynx will recognize the VITC Card on power up and the VITC LED on the System Unit OPTION Section will turn on.

### **Install the VITC Option Card (New Metal Work)**

1. Turn off the power and place the Micro Lynx System Unit on a static safe workstation. Ground yourself and the workstation anti-static mat.
2. On the back of the System Unit, remove cover labeled VITC READER.
3. Remove the six phillips screws securing the top cover to the System Unit.
4. Position the System Unit so that the front panel faces you, and remove the top cover.
5. Locate and remove the black rubber bumper on the corner of the VITC Card.
6. The VITC Card is mounted to the left of the Main Board, component side up. The VITC Card will lie flat in the chassis.
7. If you have the M3 or ACG Card already installed in the Micro Lynx, remove the Option Card cable from J3 on the Main Board before installing the VITC Card.
8. Slide the VITC Card against the back panel so that the VITC IN and VITC THRU jacks are seated in the appropriate cutouts in the back panel. Insert the washers and nuts onto the BNC connectors.
9. Insert the four phillips screws through the VITC Card into the chassis and tighten. (See Figure 10-18.)



**Figure Chapter 10 -18. Securing the VITC Card**

10. Insert the Option Card cable connector into J1 on the VITC Card.
11. Connect the end of the cable into J3 on the Main Board. The unused connectors on the left of the cable will lie in the open area, unless you have option cards installed.
12. Replace the top cover and the six phillips screws.
13. Power up the System Unit. The Micro Lynx will recognize the VITC Card on power up and the VITC LED on the System Unit OPTION Section will turn on,

## Operation Instructions

Operation of the VITC Reader Card is extremely simple, and once configured operates transparently to the user. When a VITC Option Card is installed in the Micro Lynx SU the card is automatically detected by the system. The VITC LED on the front panel of the system unit and the F3 LED on the Keyboard will come on to indicate that the VITC Option Card is present and correctly communicating.

To configure the VITC Card, the line scan mode and group assignment need to be selected. Use Setup VITC to specify the correct settings for your system. Enter setup mode by pressing the [SETUP] key followed by [F3] to select the VITC setup options menu. Use the [NEXT]/[LAST] and [+]/[-] keys to set the correct options from the menu.

## [F3] VITC Options

Table Chapter 10 -7. F3 Setup Options

KEY	MENU	SUB-MENU	RANGE
F3	VITC Options	0 Group Select	Off, A, B, C
		1 Reader Mode	Auto, Fixed

**Group Select** Use the group select option to allocate the VITC reader to a specific Micro Lynx machine. This should be set to the same machine (A-C) that the video transport is connected to. Make sure that a BNC to BNC cable is connected between the video out jack on the video transport and the video in jack on the Micro Lynx VITC Card.

**Reader Mode** **Auto.** Automatic mode will always find and select the lowest pair of matching lines. If this pair of lines is lost for any reason then the VITC Card will scan for the next matching pair of lines on the tape. If the VITC board finds another pair of lines then it will automatically switch to the new lines and display the warning message "VITC Lines changed". This mode of operation is extremely effective when there is only one pair of continuous lines on the tape. If the VITC on tape is discontinuous or because of the video editing process there are several pairs of discontinuous VITC lines on tape then fixed reader mode should be used.

**Fixed.** In fixed mode, a single pair of VITC lines can be selected. When a pair of lines is selected, the VITC reader will only read these lines.

**Selecting VITC lines.** To display or select specific VITC lines, press the F3 key, the display will show the numbers of the lines that the VITC reader has found on the video tape. The lines selected by the automatic line select mode are indicated by A's in the display and the fixed lines indicated by f's. To select lines in fixed mode use the [LAST]/[NEXT] keys to choose line 1 or line 2 and then the [+]/[-] keys or the Jog/Shuttle wheel to pick a specific line. The number of lines displayed is automatically adjusted for NTSC or PAL operation so only correct lines are available for selection.

## VITC Display and Status

The keyboard VITC LED status indicator will come on when any matching pair of VITC lines is detected on tape whether the lines are selected not.

A lower case "v" is placed in the display next to the machine letter when the displayed machine or group time code is being updated by the VITC reader board. The time code display is normally LTC

and will automatically switch to VITC when the video tape machine is in still mode or moving at less than 1/3rd play speed.



## Introduction

The appendix has four sections: SMPTE Made Simple, Setup Quick Reference Guide, Cabling Reference Guide, Error Messages, and Glossary.

## SMPTE Made Simple

Provides basic information and various applications using SMPTE time code.

## Quick Reference Guide

A graphical chart of the Micro Lynx Setup Options.

## Cable Reference Guide

Provides setup and cabling information to help you configure and use the Micro Lynx.

## Auto Serial Transport Table

Contains a list of the serially controlled transports currently recognized by the transport menu setting AUTO Serial TRANSPORT.

## Key Combination Guide

Provides Key and Key Combination Identification Numbers for “stuck key” errors.

## Glossary

An alphabetic list of terms used during the discussion of the Micro Lynx.



# SMPTE Made Simple

## The Time Code Tutor from TimeLine

---

### Introduction

When the television broadcast industry moved from film and live performance to prerecorded video production, a method was required to reliably synchronize and edit the new medium. Historically, film rushes were lined up at the clapper board and rubber stamped with footage numbers, and by default film was mechanically held in sync by the sprocket holes. Unfortunately, video tape had neither of these attributes. This created a problem of how to get the music, pictures, dialogue, and effects all to begin and run at the same time.

The solution was SMPTE time code. SMPTE is a signal with specific address information that can be recorded on audio or video tape and used to position them, accurately.

### Why SMPTE?

In 1971, the Society of Motion Picture and Television Engineers chose **SMPTE** to be the industry standard for synchronization. It became officially known as SMPTE/EBU Time Code when the society was joined by its' overseas counterpart, the European Broadcast Union (EBU). Since it is quite a mouthful, most people just say SMPTE.

### What Can You Do with SMPTE?

There are hundreds of uses for SMPTE time code in every branch of audio production. They include records, video, film, advertising and industrials. Let's start with the how and why of some of the most basic applications.

## Synchronizing Multiple Audio Machines

Imagine you are a recording engineer. You've just used up all the available tracks on your multitrack machine, but your project is nowhere near completion. How are you going to get some extra tracks? Use a second multitrack recorder.

The question is, "how do you lock the two machines so that the music plays back in perfect synchronization – first time, every time." You *could* try to hit the Play buttons on both machines at exactly the same moment and then cross your fingers, but the odds of this working even once are *very* slim.

The correct solution is to use SMPTE time code *AND* a TimeLine synchronizing system. It works like this: a TimeLine Lynx or Micro Lynx generates time code that is recorded onto the audio tapes. The time code is then used as a common reference point, the "glue" that holds the two machines in sync.

On playback, a SMPTE time code reader reads time code from one tape recorder and passes the timing data to a synchronizer connected to the other tape recorder. Based on this incoming time code, the synchronizer regulates the playback speed of the slave so that it always stays in perfect sync with the master.

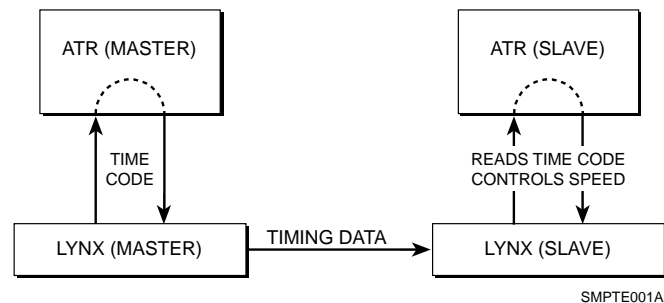

**Figure Appendix A-1. Basic SMPTE Time Code Setup**

This simple example is the basis for all SMPTE applications. For instance, if you are locking to film or video using a digital audio workstation or a sequencer, you'd just substitute the appropriate controlling device to suit the equipment for that application.

## Locking to Picture

Suppose you have footage on videotape and you need to create an audio track to go with it. It could be music, dialog, effects, or all three. How do you lock the sound to picture?

Use SMPTE and a Micro Lynx or two Lynx modules, exactly as described in the previous audio example. SMPTE works just as well with video as it does with digital or analog tape. You can use SMPTE to lock video to analog, digital to analog, in fact, just about anything to anything; even sound sources that don't use tape.

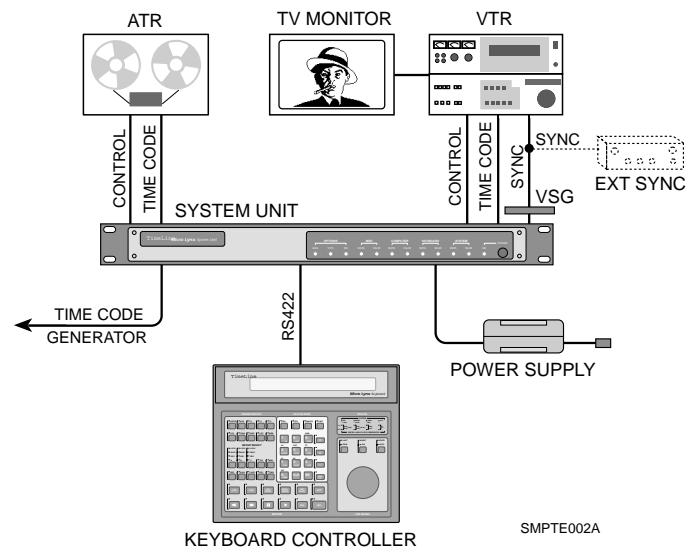

Figure Appendix A-2. Synchronize to Video

## Mix Automation and More

If you have a MIDI sequencer and some synthesizers that you want to lock to your multitrack tape or to picture, the TimeLine Micro Lynx can translate SMPTE time code into the MIDI data that the sequencer needs to lock to tape.

SMPTE can be used to control just about anything that has micro processor intelligence – and what piece of audio gear doesn't these days? For instance, mixing console automation will run to time code and can therefore be locked to tape and other time code devices for complete system automation.

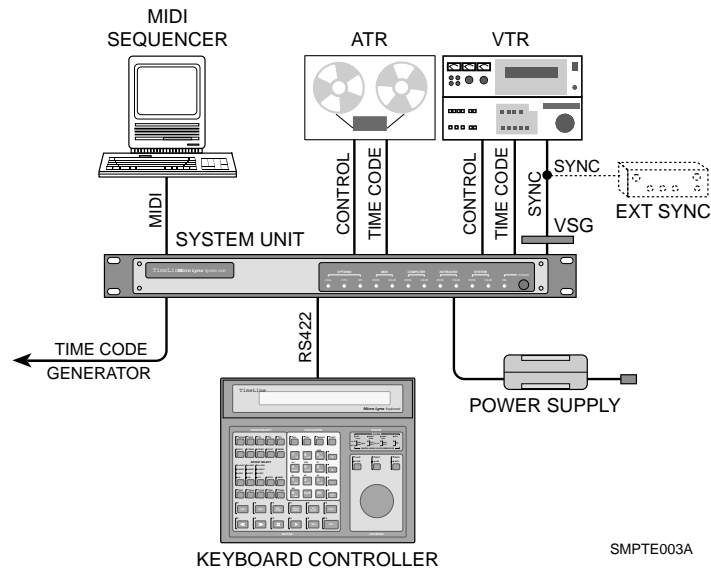

Figure Appendix A-3. MIDI Sequencer and Time Code

## Complete Systems

The ultimate SMPTE application is the complete studio system. Just as two devices can be locked to a common time reference, so can a whole roomful: tape machines, consoles, synthesizers, effects processors, and hard disk recorders. With an efficient controller like the Micro Lynx Keyboard, all of these different machines can be operated as easily as a single set of transport controls. Later, we'll explain how SMPTE is used to build large, multi-machine networks for video editing and music recording.

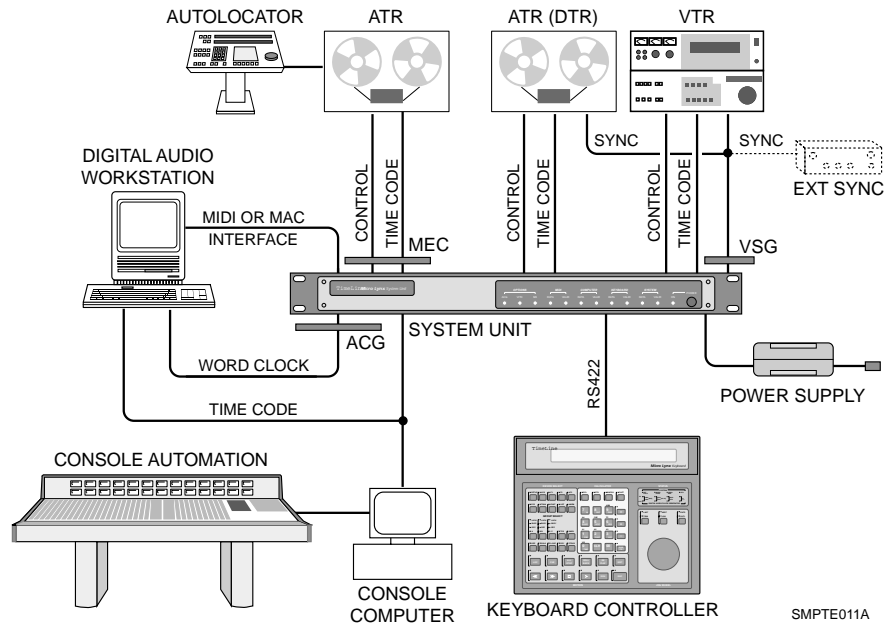

Figure Appendix A-4. Complete Studio System

## How Does SMPTE Do It?

If you know precisely where a piece of program is and how fast it is playing, then it is possible to use this information to control other machines so that they are all in the right place at exactly the same time. SMPTE does just this, it is an absolute timing reference that indicates both the speed and position of a tape as it travels across a tape machine transport.

### What You Can Do with a Speed Reference

Many pre-SMPTE sync codes could only indicate speed. The most widely used was control track or pilot tone. Pilot tone is an audio signal derived from a stable source, historically 60 Hz AC wall current. By reducing the voltage with a suitable transformer, the resultant continuous sine wave could be recorded on tape.

Machine speed is normally regulated by monitoring tach pulses from the tape machine's capstan motor. They indicate how many times the capstan revolves in a given time interval, just as an automobile's tachometer indicates how fast an engine is turning.

When playing a tape with pilot tone back, the sine wave on tape is compared with a reference sine wave coming from the wall current or some other guaranteed signal.

If the tape slows down, the frequency of the pilot tone, or the number of cycles that tick by each second, will decrease. If the tape speeds up, the frequency will increase. A controlling device, tied into the tape machine's capstan motor, senses the difference between the reference tone and the pilot tone on tape; and varies the speed of the tape machine motor to make the two match up again.

This process of matching tape machine speed to a stable reference is called resolving. The two sets of sine waves are brought *in phase* with one another, so they match up perfectly, peak for peak, trough for trough. Which is why this is sometimes called phase locked.

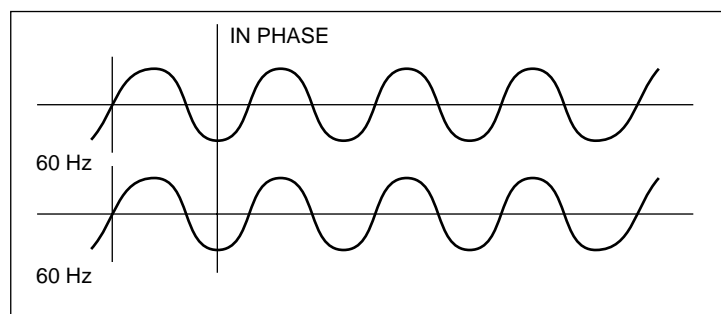

SMPTE004A

Figure Appendix A-5. Two Sine Wave Signals in Phase

Just as pilot tone on one tape machine is made to match the reference source, it can also be made to match pilot tone on a second master tape machine. Thus, pilot tone can be used to synchronize the speed of the two tape machines.

**However, There Is a Problem:** One sine wave looks exactly like another. While the slave machine can phase lock with the master, it has no way of knowing whether the master is playing the first verse or the third chorus or if the master is three-and-a-half seconds into a scene or right at the beginning. As a tool for synchronization, pilot tone is severely limited. The same is true for other *speed only* sync codes such as Frequency Shift Key (FSK) and Din Sync.

To work, master and slave must be carefully lined up at the beginning of playback and there's no way to run the machines accurately to the middle of the program material since the slave never knows where the master is, *only* how fast it is playing.

## SMPTE: What You Can Do with a Speed and Position Reference

This is where SMPTE time code enters the picture. As we said, SMPTE indicates not only tape *speed*, but also tape *position*. SMPTE time code is a complex digital signal, equivalent to the simple, analog pilot tone signal with a unique number assigned to each cycle of the sine wave.

Time code is recorded onto tape as an audible signal – a rapid-fire series of *blips*. These blips are “read” by a microprocessor as a unique number: an address, consisting of separate numbers for hours, minutes, seconds and fractions of a second, called frames.

So, if you have a gunshot at the climactic scene of a suspense melodrama, SMPTE tells you exactly where the gunshot “lives;” what its address or location is on tape. SMPTE can say, “This gunshot occurs one hour, 31 minutes, 12 seconds and 19 frames into the film.” This means you can shuttle to the exact spot on tape where that gunshot occurs, and replace the existing blast with a more convincing sample; one the sound effects engineer just acquired.

Think of what that means: the master machine can find *ANYTHING* on a tape, and all slave machines will chase the master to that very same spot. At this point, we're a long way from just locking one faceless sine wave with another and rolling from the top. We've moved into the realm of position accuracy.

## Anatomy of a SMPTE Frame

A SMPTE frame or word consists of 80 bits that convey SMPTE's message of hours, minutes, seconds, and frames. Each bit is represented by a binary '1' or '0' that is specifically encoded for recording onto tape. The method used is called biphase encoding. This coding reverses the signal polarity halfway through a bit to represent a '1' and leaves the bit polarity unchanged to represent a '0'. A continuous string of these 80-bit words is recorded linearly along the tape to form the time code.

Let's look at the jobs the bits perform. Each frame is broken up into 16 groups of 4 bits and a 16-bit sync word.

- Eight 4-bit groups are assigned to the hours, minutes, seconds, and frame number.
- Eight 4-bit groups are user bits. They are reserved for information such as ID, reel numbers, session, dates or another time code number.
- The remaining bits form a sync word, to provide direction information and mark the end of the 80-bit frame.
- The time code reader uses the direction sense bits to determine whether the tape is running forwards or backwards.
- The sync word is a series of preset 1's that allow the speed and phase of two time codes to be read and compared by the Lynx or Micro Lynx module to establish synchronization.

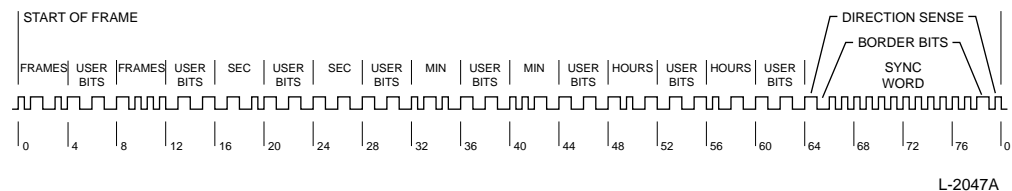

**Figure Appendix A-6. Time Code Address**

SMPTE words, one for each frame, are recorded along the length of the tape; hence the name Longitudinal Time Code (LTC). The code's design and organization make it suitable for use over a very wide range of play speeds, both forwards and backwards.

The frequency of the LTC signal is always proportional to the tape speed. However, the signal cannot be read in stop or freeze-frame mode. Consequently video frequently uses another form of time code: Vertical Interval Time Code (VITC), which can be reliably read in stop and at very slow play speeds.

## Time Code Formats

There are 60 minutes in an hour; 60 seconds in a minute, but how many frames are there in a second? Frame rate is the term used to express the number of frames-per-second in SMPTE time code. Frame rate was originally measured as one-half the power line frequency.

Since there are different power line frequencies in the U.S. and Europe, time code has several different formats, defined by the frame rate used in each country.

### National Television Standards Committee (NTSC)

Wall current in the U.S. has a frequency of 60 Hz, making 30 frames-per-second the standard frame rate for American black and white television.

### Phase Alternate Line (PAL)

In Europe, the standard wall current frequency is 50 Hz. Thus we have another format: 25 frames-per-second or the PAL format, the standard for European color television.

### Drop Frame (DF)

What about American color TV? When it was invented by RCA, they reduced the American black and white frame rate of 30 frames-per-second to 29.97 frames-per-second, to allow both color encoding and compatibility with existing black and white television sets. This became the standard color TV format for America.

The problem is that 30-frame time code running at this rate measures slightly slower than real time.

60 sec x 30 frames/sec	=	1800/min x 60 min/hr	=	108,000 frames
60 sec x 29.97 frames/sec	=	1798.2/min x 60 min/hr	=	<u>107,892 frames</u>
		Difference	=	108 frames

So for every hour, by the clock on the wall, the time code is 108 frames short. Just a few frames off might disastrously make your lead guitarist end his solo two chords early! To correct this, a time code format called Drop Frame (DF) was developed. Drop frame skips the first two frame counts in each minute (with the exception of minutes 00, 10, 20, 30, 40, and 50) to force the time code to match the clock time.

## Film

Film is our final consideration. It has run at a frame rate of 24 frames-per-second ever since Thomas Edison invented it. Although this is a “non-standard” time code, it is sometimes used in the field.

### Different Frame Rate Formats

In summary, the important thing to remember is that SMPTE conveys two pieces of information: *tape speed* and *tape position*.

Frame rate, is the speed at which the code will run, and frame type (30/DF/25/24), is the way in which frame positions are counted.

**30.** Thirty frames-per-second can be drop frame (DF) or non-drop frame. If drop frame is selected, then the actual frame count is reduced by 108 frames-per-hour.

**25.** Twenty-five frames-per-second is the European standard.

**24.** Twenty-four frames-per-second is the film standard.

Table Appendix A-1. Frame Rate Formats

Counting Rate (Hz)	Counting Method (Frames-per-Second)	Displayed Time Accuracy	Application
24	24 frame	Real Time	Motion pictures and film
25	25 frame	Real Time	EBU standard for European television
29.97 <sup>1</sup>	30 drop frame <sup>3</sup>	Real Time	NTSC standard USA & Japan
29.97 <sup>1</sup>	30 non-drop frame <sup>4</sup>	0.1 % slow	USA & Japan
30.00 <sup>2</sup>	30 drop frame <sup>3</sup>	0.1 % fast	Non-standard
30.00 <sup>2</sup>	30 non-drop frame <sup>4</sup>	Real Time	USA & Japan

<sup>1</sup> 29.97: Generated by all “color television” sync generators (i.e., almost all sync generators built after 1970). This is the speed at which a “black burst” signal runs (not to be confused with “black & white”). It is a standard color signal with a “color of black.” *Use this* as your standard frame rate unless you are an expert and have a reason not to.

<sup>2</sup> 30.00: Usually available only in “internal crystal mode” of a time code generator, or from black & white television sync generators. *Don't use* this non-standard speed unless you are an expert and have a good reason. This is sometimes used in conjunction with motion picture film systems.

<sup>3</sup> Skips 108 frames/hour at regular intervals.

<sup>4</sup> Many users prefer 30 (full frame) counting because no numbers skip in the counting sequence, even though the elapsed time accuracy at 29.97 frame rate is slightly different from real time.

## VITC

Vertical Interval Time Code (VITC) is another form of SMPTE that is used only with video, and is printed horizontally at the beginning of each field, as part of the video signal. Longitudinal Time Code (LTC) is printed linearly along an audio track.

Unlike LTC, VITC cannot normally be added to a video tape after the picture has been recorded. It must be recorded with the video signal when the original tape is generated.

Each picture has 525 lines (625 for PAL). To facilitate picture clarity, the lines are divided into two interlaced (odd and even) fields. This means that 262 even lines are scanned, then the scanner returns to the beginning of the picture and scans the 263 odd lines. As the lines are scanned, a number of lines at the top and bottom of the picture are never displayed; they are “blank” space. These lines are available to store information. VITC is recorded on two of these spare lines, at the top of each field. One complete VITC data word is recorded on each line.

VITC uses a 90-bit data word instead of the 80-bit data word used by LTC. The extra bits are used to provide error correction and to prevent bad time code values from being read. VITC allows accurate reading of tape position even when the tape is stopped in freeze frame, which is something that LTC can't do. VITC is often used in conjunction with LTC in applications that involve both audio and video.

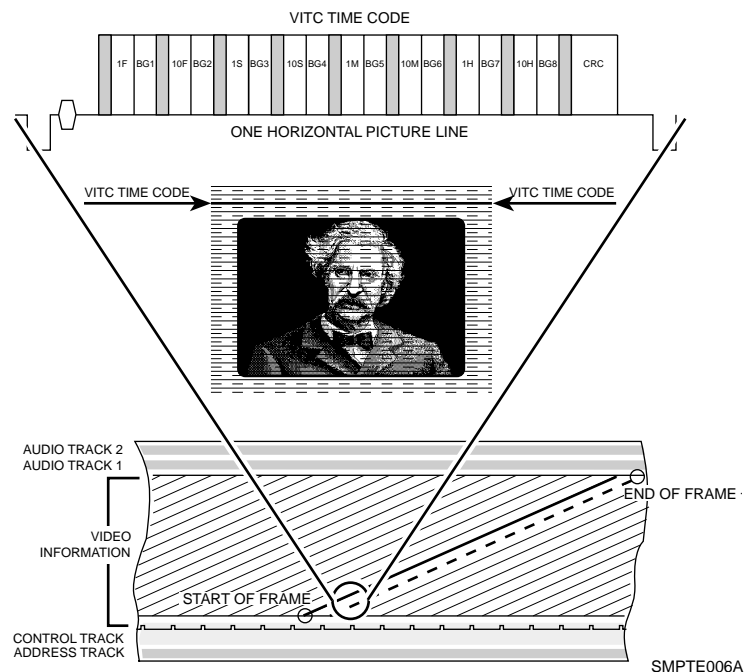

Figure Appendix A-7. Video Tape and VITC Time Code

## SMPTE, MIDI and MTC

MIDI is not the same as SMPTE, even though both are binary codes. They each carry very different types of information.

SMPTE, as we've seen, answers the questions "Where are we," and "How fast are we going?" MIDI however, answers an equally vital but totally different question, "What do we do now?" It answers that question for synthesizers, drum machines, and other electronic music devices. MIDI is the language that a computer uses when it tells a synthesizer, "Play middle C, play it mezzo forte, and play it ... *now!*"

But when is *now*? If we're talking about playing back an electronic composition in concert, *now* is a relative term. *Now* might be the third beat of the fourteenth measure, and whether that beat hits at 10:31 or 10:32 PM is something no one usually notices. However, if that beat has to coincide with the cocking of an assassin's pistol in a feature film thriller, or coincide with a soul-wrenching wail from a vocalist on audio tape, it becomes necessary to pin *now* down.

The traditional way is to slave a MIDI sequencer to SMPTE. Many popular sequencers can read incoming SMPTE and lock their musical tempos (their beats-per-minute) to the time code.

It works beautifully, but it leaves the film or TV composer with the awkward situation of flitting continually between two highly dissimilar sets of numbers. While his sequencer counts beats and measures, his work print, cue list, director's instructions and everything else that pertains to the visual side of the equation, all talk of hours, minutes, seconds and frames. The two sets of numbers never coincide neatly, forcing the composer to pull all sorts of tricks on his sequencer.

MIDI is a computer code that uses 8-bit data words or bytes that cannot contain SMPTE's 80-bit word. This is the reason for the invention of MIDI Time Code (MTC). MTC, quite simply, takes SMPTE time code and translates it into the MIDI data format. To translate SMPTE into MIDI, the MIDI time code format transmits a MTC message byte every 1/4 frame. The first two 1/4 frame bytes contain only the frames. The next two MTC bytes convey the seconds, the next two the minutes, the next two the hours, and so forth.

This whole process takes exactly two SMPTE frames to complete. As soon as one complete SMPTE address is transmitted, the MTC generator updates the time code by 2 frames and starts again.

The TimeLine Micro Lynx and Lynx System Supervisor Unit can take SMPTE from a master tape and generate MTC. Thanks to this, the film/TV composer can now use a cue-sheet style program, as well as conventional music, and if desired, deal exclusively in the realm of hours, minutes, seconds, and frames.

Although SMPTE and MTC are not the same thing, they make a powerful combination when the Micro Lynx or System Supervisor puts them together.

## Using SMPTE

Any SMPTE time code application involves three basic functions. First you need a generator to produce the actual SMPTE signal that goes onto tape. Second, you need a reader to read the SMPTE time code from tape. Finally, there's the job itself – what you want to accomplish.

SMPTE can be used with a resolver, to ensure that a single tape machine runs at a consistent speed. It can also be used with an autolocator that stores a number of SMPTE addresses in memory and chases to those addresses on command, or when you want to lock one or more devices to a master tape machine with a synchronizer.

In the early days, a different device was quite often required to perform each of these functions. Today, TimeLine has several products that perform them all: the Lynx Time Code Module with a Keyboard Control Unit, compact, high-end, high performance units; and the Micro Lynx, a high performance project or smaller studio system.

## Things To Know About Generating Time Code

Time code, generated and striped on tape, must ultimately be played back and read, so you must determine the optimum level for your master tape before generating the time code. Master tapes are generally printed at about -6 dB. If you print code at too low a level, the reader will have trouble reading it, but if you print it too hot, it will bleed audibly onto adjacent tracks. For this reason, many engineers leave a guard band – a blank track next to the time code track – even when printing at the correct level. To remove the need for leaving two blank tracks (one track on either side), time code is usually printed on the outermost track in multitrack formats (i.e., track 24 on a multitrack machine).

In video and digital audio applications, always make sure that the time code generator and machines are properly referenced together when printing time code. Your generator must be connected to the same external video sync signal as the video or digital machine, otherwise, when synchronizing, the video machine's will start off in the right place, then slowly drift apart.

With digital audio machines, the sample rate or word clock must be locked to the time code. This is normally done by using a video sync signal as a common timing reference for the generator and the digital machine. Set both to "EXT VID" before printing time code. If you do not have a sync pulse generator, the Micro Lynx Video Sync Generator (VSG) option card can be installed and used to generate a referenced composite sync signal for your video or digital machine.

Specific types of video sync include black burst, color bars and composite. These video sync signals are often collectively called *house sync*, or the signal that's universal throughout the production facility or house. To reference your generator to video sync, set it to "EXT VID" mode and connect a video sync signal. This ensures that the tapes you are striping will have a common reference and on playback will sync properly.

## Reshaping Time Code

Reshaping, or cleaning up the time code signal, should always be performed when dubbing time code from one tape to another. If you simply copy time code from one tape to another without reshaping, it will deteriorate quickly due to generation loss and will eventually become unusable. Reshaping is not recommended when the time code on tape has begun to deteriorate badly.

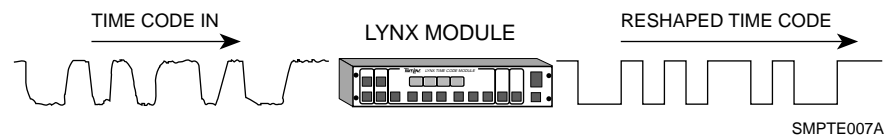

Figure Appendix A-8. Reshaping Time Code

When reshaping, existing code is passed through the reader, which puts out "squared-up" code. If a tape has been copied several times or is very worn, then it is likely that the time code will have dropouts or bad spots that a time code reader will not be able to read. The reshape output of a time code reader can only put out a clean copy of its input. So if the code drops out completely, the reshaped output will have a corresponding dropout. To overcome this, the code must be regenerated rather than reshaped.

## Regeneration or Jam Sync

Jam Sync, is a generator function that is a better alternative to reshaping. It is used to create a new time code that is related to an existing time code on tape. It is extremely useful for repairing a break in an existing time code track, or creating a continuous time code track from an edited or discontinuous track. Code is read up to the last “good” address. Then the generator uses the next consecutive address to generate new code.

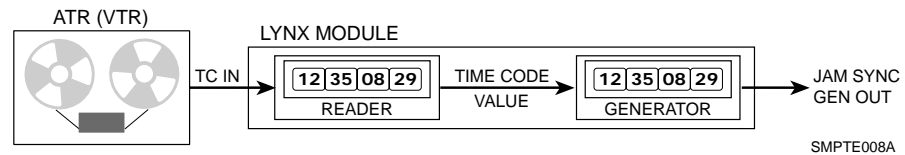

Figure Appendix A-9. Jam Sync

Jam sync is used extensively in video editing; where different pieces of tape, each with different time code, are spliced together. Jam sync provides the resulting program with continuous time code. TimeLine’s Micro Lynx and Lynx both have manual and automatic jam modes, that quickly and simply let you repair or create new time code tracks to overcome the problems that are detected with bad code.

## About Time Code Readers

A Wide Band Reader, such as the Lynx Time Code Module or Micro Lynx, reads time code even at the high tape speeds used for Fast Forward and Rewind. Wide band reader capabilities are essential, since SMPTE addresses provide the only accurate means of locating positions on tape.

If time code on tape becomes unreadable, the TimeLine readers automatically search for the next best sync source on tape. After SMPTE, the reader searches for serial time code, then pilot tone, and finally tach pulses that are derived from the rotation of the tape machine’s capstan motor.

## Synchronizer Essentials

A synchronizer reads time code from two or more machines; then by manipulating the speed of each machine’s capstan, it forces the two machines to play tape at the same speed. This process is called locking. The Micro Lynx system offers the following synchronization mode.

## Phase or Sync Lock

Phase or Sync Lock emulates the old control track or pilot tone method of synchronization. The TimeLine system reads the time codes and synchronizes the transport, taking into account any deliberate offsets. Once the system is locked, the slaves only use the speed information that is derived from the time code, and specific time code addresses are ignored.

This allows the tape machines to stay in lock even if the time code relationships change. The time code change is reported, but the synchronizer makes no corrective action. This is the normal method of operation.

## Advanced Applications

### Video Editing

Video editing is the process of assembling raw footage into a finished television program. Shooting the raw footage is part of what's called television production. Video editing is part of the post-production process. Consider an average television program, perhaps a sitcom or a documentary. The action constantly shifts from one scene to another, moving indoors, outdoors, all over the place. Within a given scene, the perspective also shifts (i.e., from one camera to another, each shooting the scene at a different angle).

In editing, there are multiple video machines, each loaded with footage of different scenes, shot by different cameras. The potential for chaos is great. Fortunately, there's SMPTE time code. Each reel of raw footage is striped with SMPTE, and each frame has a specific and unique location or address. In some cases, both LTC and VITC are on the tape.

During editing, selected scenes of raw footage are transferred onto a master video tape, one after another in sequence, as they will appear in the finished show. The master video tape, as its name implies, contains the master or program time code.

A video editor, locks the source video machines loaded with raw footage to the master video machine. Additionally, one or more audio tape machines may be locked to the master. These contain the production audio: the dialog and incidental sounds recorded during shooting of the raw footage.

Video editing is normally a two-stage operation. First comes offline editing. The person editing the show receives work tapes, i.e., copies of all the raw footage, with time code “burned in” so that it’s visible in one corner of the picture. Any footage initially shot on film, is usually transferred to video at this point. From the work tapes, a basic sequence of scenes is selected. For example, the second scene should be the bar room brawl that occurs, say, between addresses’ 05:40:59:11 and 05:44:12:22 on one of the raw footage reels. In the finished program, this scene needs to start exactly six minutes, five seconds and nine frames (00:06:05:09) into the show and run to 00:09:18:20.

When all the scenes have been sequenced in this manner, an Edit Decision List (EDL) is compiled. The EDL is a complete, computerized directory of the location of the scenes in the show, along with the addresses locating each scene in the raw footage.

Later, when the project moves to online editing, the EDL can be downloaded and the final video master assembled from the original raw footage, which has been pristinely sitting aside while the work tapes endured the rigors of offline editing.

## Audio-For-Video

Just like the raw video footage, all the audio elements that go into a video production must be assembled. This procedure is generally known as audio-for-video or audio post-production. There are several different branches of audio post, since there are many different types of sound sources that go into a typical video show.

First, there’s production audio, which is dialog and sounds recorded during shooting. Often, incidental noises on the set, flubbed lines, and other uncontrollable aspects of the shoot make the production audio unusable. Which brings us to the three main branches of post-production audio.

For dialogue, there’s Automated Dialog Replacement (ADR) in which actors re-record production dialog in the controlled acoustic environment of a sound studio. This replacement dialog is recorded onto audio tape that is locked to a video work print, which the actors carefully watch as they read their lines.

Second, is Foley (named after the man who invented it), the process whereby an abundance of “real-life” sounds, i.e., footsteps, coat zippers, car door slams, etc., are recorded by specialized actors called Foley walkers. They also make their recording while watching a work print that’s synchronized, by SMPTE and a TimeLine synchronizer to an audio tape machine that records the sounds they make.

Third, are sound effects. This is mainly the spectacular stuff – explosions, rocket blasts, gunshots. Today, most sound effects work, as well as some Foley, is created using digital audio samplers. Samplers are devices that can be locked to SMPTE through MTC or MIDI.

Then there's that all-important audio element – music. This is supplied by the composer, who works to rough cuts (preliminary edits) of the finished show and ultimately to the finished video master. The composer may record real instruments onto audio tape that is locked to picture using SMPTE and Lynx modules, or he may work with MIDI instruments that are locked to tape by a Micro Lynx or Lynx System Supervisor.

Ultimately, there are a number of different Audio Tape Machines (ATRs) or film dubbers with the finished music, dialog, and effects. These ATRs are locked to the video master using a TimeLine system controller, such as the Keyboard Control Unit or Console Control Unit. Then the multiple audio sources are balanced by a mixing console to provide a finished audio master for the program. Because this can be quite an elaborate process, many modern post-production facilities use automated mixing consoles, which store mix data, such as fader moves, mutes, etc., in computer memory. These automated systems can also be locked to the video and audio tape machines via the Lynx System Supervisor and Lynx console interfaces.

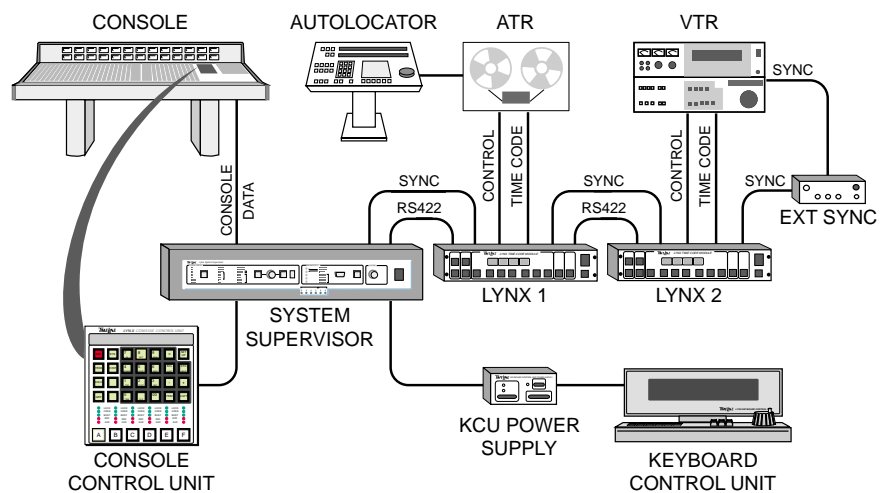

SMPT010A

Figure Appendix A-10. Automated Mixing System

## The Modern Electronic Recording Studio

Today, many record projects and other music recording applications are as elaborate as video post-production, with the number of machines involved and the use of SMPTE time code. Two multi-track tape machines are typically locked together by the Micro Lynx to provide enough audio tracks for instruments and vocals. Some productions require more than two interlocked multitracks. Console fader automation is also the norm for record mix downs, and an absolute necessity for “dance” mixes.

In addition, many projects also involve virtual tracks. Virtual tracks are MIDI synthesizer and drum machine parts that are synchronized to tape, and played back “live” in real time, rather than being recorded onto multitrack. The Micro Lynx provides the all-important SMPTE to MIDI translation.

MIDI is also the protocol used to automate effects processors, such as digital reverbs, harmonizers, etc. These MIDI devices can change programs mid-song, and even perform real time individual parameter changes mid-program. Some mixing consoles, particularly those designed for personal use and project studios also have MIDI automated switching or mixing features.

In short, just about every device in the recording studio – tape machines, consoles, effects processors, and electronic instruments, can now be automated using SMPTE, and MIDI, and the appropriate TimeLine equipment. Thus the Electronic Recording studio is created.

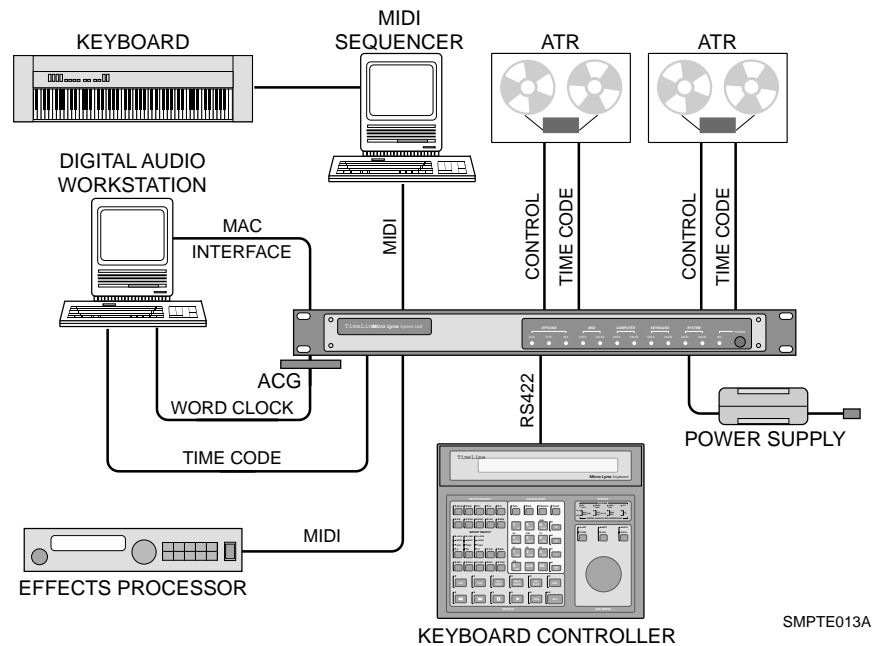

Figure Appendix A-11. The “Modern” Electronic Studio

## SMPTE and the Digital Audio Workstation

The Digital Audio Workstation (DAW) is an important tool for post-production and music recording. The DAW records, edits, manipulates and mixes multiple tracks of audio in a single digital environment. Like the biosphere, it's a self contained, self-sufficient system; but at some point, it must sync with the real world. Digital audio workstations must eventually be slaved to picture or a master tape machine.

This can present a problem. DAWs are always referenced to their own internal sample rate clock. The workstation can use time code to locate and park at a specific SMPTE address. When that address comes up on the master tape, it goes into play; but it's running "wild," locked to nothing but its own internal clock. In short, we're back to something only just a little better than the scenario presented in the beginning: attempting to press two start buttons on two machines at the same time and crossing our fingers.

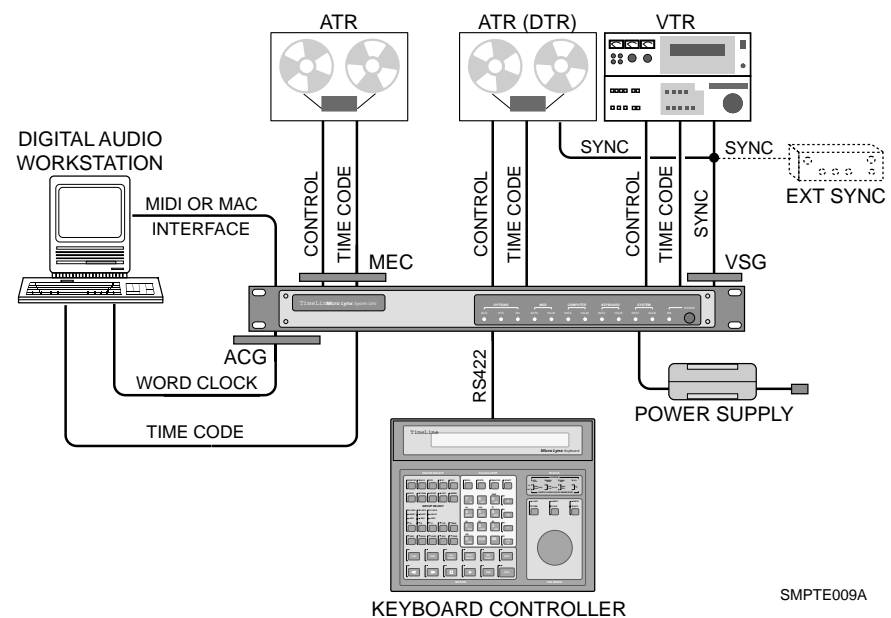

Figure Appendix A-12. Micro Lynx with a Digital Audio Workstation

An excellent solution to the problem is offered by the Micro Lynx Digital Audio Clock Generator (ACG) Card option. It provides a means of referencing the digital audio workstation to the master time code, using word clock (sample rate) data or AES/EBU digital audio bit stream, which contains timing data. The ACG card generates a *digital audio* clock that is locked to the Micro Lynx system reference, and DAW uses it to lock and run its internal sample rate clock.

It's even possible to varispeed the master tape. The Digital Audio Clock Card automatically adjusts the ACGs word clock rate. If the tape speeds up or slows down, the DAW will adjust to match the new play speed (within the limits of the disk system).

As we enter the digital era, time code continues to be an important, practical solution to multiple equipment communication and control.

## The SMPTE Future

SMPTE Time Code and MTC are already being used for applications far beyond their original purpose. Outside the worlds of music recording and video post-production, SMPTE is used to automate light shows at rock concerts, control laser beams at theme park attractions, and trigger flashpot explosions.

Its uses are many and they will continue to grow as time goes on. HOWEVER, the basics of SMPTE will never change. Now that you know them, you're ready for the future.

# Setup Quick Reference

Table Appendix A-2. Setup Quick Reference Guide

[SETUP]	[ACG]	[GRP]	[ROLLBACK, REH, REC]	[TRKS]
[0] NOM S/RATE OUT	32.000 Ks/s 44.056 Ks/s 44.100 Ks/s 47.952 Ks/s 48.000 Ks/s	[0] SEARCH MODE CHASE GROUP ON	[ROLLBACK] OR [0] ROLLBACK KEY ROLLBACK PLAY-REV	[0] VIDEO TRACKS SAFE READY
[1] VAR RATIO OUT	OFF ON	[1] REF FOLLOW MSTR OFF ON	[REH] OR [1] REHEARSE BY PLAY+REH REH ONLY	[1] VIDEO AUTO-RST OFF ON
[2] VAR RATIO OUT %	85%-115% (100.00%)	[2] GROUP PARKAHEAD 0-30 (25)	[REC] OR [2] RECORD BY PLAY+REC REC ONLY	[TRAN] MACHINE SELECT [LAST/NEXT] TRANSPORT MFGR [+/-] MACHINE MODEL [TRAN] TRAN OPTIONS <sup>2</sup>
[3] OVERSAMPLE OUT	128 192 256 384	[3] GRP LED STATUS NORMAL TIMECODE	[SYS] SYSTEM OPTIONS	[0] CAPSTAN MODE WILD RESOLVED
[4] NOM S/RATE IN	32.000 Ks/s 44.056 Ks/s 44.100 Ks/s 47.952 Ks/s 48.000 Ks/s	[LOOP] LOOP OPTIONS	[0] LED BRIGHTNESS 20%-100% (100%)	[1] CAPST SPD TRIM -128 TO +127 (0)
[5] VAR RATIO IN	OFF ON	[1] AFTER REPLAY RE-EDIT REPLAY	[1] DSPL CONTRAST 30%-100% (70%)	[2] LIFTER DEFEAT NEVER NORMAL NOT STP/PLAY ALWAYS
[6] VAR RATIO IN %	87.5%-112.5% (100.00%)	[2] AFTER END END REPEAT STOP RECUE	[2] DSPL TIMEOUT OFF 1 MIN 5 MIN 10 MIN 20 MIN NEVER	[3] RECORD IN PULSE REC P-REC,PLAY
[7] OVERSAMPLE IN	128 192 256 384 OFF	[MACRO] PROGRAM MACRO [0-9] (1,2,3,8 & 9)	[3] JOG SPEED 1-10 (5)	[4] RECORD OUT PULSE PLAY P-REC, PLAY PULSE STOP P-REC, STOP P-PLAY, STOP PULSE OPTO SPECIAL OPTO
[8] REFERENCE IN	AES/EBU CLOCK IN BNC	[MEM] MEMORY OPTION MEMORY SIZE 0-9 00-99	[4] TRIM FRAME 01-10 (01)	[5] REHEARSE IN LATCH REH PULSE REH P-REH,PLAY P-REH,RECLOG L-REH,RECLOG PULSE REC
[EDIT] EDIT OPTION	[0] EDIT Q/C DISABLE RETRY STOP	[MIDI] MIDI OPTIONS	[5] TRIM SUBFRAME 01-25 (01)	[6] REHEARSE OUT UNLATCH REH PULSE PLAY SAVE AS REC
[EVENT] SELECT GPI OPTIONS <sup>1</sup>	[1] GPI 1 NORMAL AUTOSET REC TALLY EDIT REC REH TALLY EDIT REH LOCK TALLY	[0] MIDI OUT JACK OFF MTC MIDI DATA MTC + DATA I/F THRU	[6] PORT SELECT MAC: MIDI, 422:ES MAC: ES, 422:OFF	[7] APPROACH SPEED 20-254
[2] GPI 2	[0] MODE NORMAL AUTOSET REC TALLY EDIT REC REH TALLY EDIT REH LOCK TALLY	[1] I/F OUT JACK OFF MTC MIDI DATA MTC + DATA MIDI THRU	[TCG] TCG OPTIONS	[8] BANDWIDTH LIMIT OFF ON
[1] BEEP MODE	OFF ON	[2] MAC OUT JACK OFF MTC MIDI DATA MTC + DATA	[0] SYSTEM REF INTFIX INTVAR EXTVID AUX VSO MASTER ACG	[9] READER MODE LTC/SER TC LTC/TT1 SERIAL TC T.TIMER 1
[2] BEEP SPACING	10-30 (20)	[3] MIDI THRU JACK MIDI IN MIDI OUT	[1] SYSTEM SPD/CODE 24 Hz/24 25Hz/25 (PAL) 29.97Hz/DF 29.97Hz/30 (NTSC) 30Hz/DF 30Hz/30	[00] MUTE CONTROL NORMAL UNTIL RSLVED UNTIL LOCKED NOT LOCKED
[3] LAST BEEP	MUTED ON	[4] MTC SOURCE MIDI IN JACK I/F JACK MAC JACK	[2] VARISPEED % 87.5%-112.5% (100.00%) [+/-] = ±0.01%	[NEXT] LOCK THRESHOLD 0-50 (35)
[RDY] RECORD OPTIONS <sup>2</sup>	[0] REC ADV 30-IN 0-255	[5] MIDI DATA SRC MIDI IN JACK I/F JACK MAC JACK	[3] TCG GROUP MODE PLAY, RUN PLAY, MUTE PLAY, WIND	[NEXT] LOCK DELAY 0-50 (10)
[1] REC ADV 30-OUT	0-255	[6] MIDI RESOLVE OFF ACG SERVO	[4] TCG STILL MODE OFF ON	[NEXT] PARK WINDOW 0-10 (10)
[2] REC ADV 15-IN	0-255	[RDY] RECORD OPTIONS <sup>2</sup>	[5] AUX OUTPUT SEL PILOT RESHAPE 1 RESHAPE 2 RESHAPE 3 GPI-2 BEEP	[F3] VITC OPTIONS [0] GROUP SELECT OFF A B C
[3] REC ADV 15-OUT	0-255	[0] REC ADV 30-IN 0-255	[6] VIDEO SYNC GEN OFF ON	[1] READER MODE AUTO FIXED
[4] REC ADV 7.5-IN	0-255	[1] REC ADV 30-OUT 0-255		
[5] REC ADV 7.5-OUT	0-255	[2] REC ADV 15-IN 0-255		
		[3] REC ADV 15-OUT 0-255		
		[4] REC ADV 7.5-IN 0-255		
		[5] REC ADV 7.5-OUT 0-255		

NOTE:  
ALL KEYS ARE IN BRACKETS [ ].  
FACTORY DEFAULTS ARE ITALICIZED.  
1 PRESS EVENT KEY THEN DESIRED GPI NUMBER.  
2 SELECT RDY OR TRAN, THEN MACHINE (A, B, OR C)  
TO SETUP OPTIONS.  
3 USE KEYS 0, 1, 2 ONLY AFTER FIRST SELECTION.



# Cable Reference Guide

**Table Appendix A-3. Cable Reference Guide**

<b>Micro Lynx Transport Control Cables</b>				
<i>TimeLine Part No.</i>	<i>Transport Manufacturer</i>	<i>Machine Model</i>	<i>Setup Menu Description</i>	<i>Cable Type Description</i>
71C062	Accom	WSD	WSD	<b>Micro Lynx Serial</b>
Special Order	AEG	M-20	M-20	<b>M-20</b>
71C065	Akai	ADAM	DR-1200	<b>DR-1200</b>
71385	Alesis	AI2/ADAT	AI2/ADAT	<b>AI2/ADAT</b>
71C037	Ampex	ATR-100	ATR-100	<b>ATR-100</b>
71C038	Ampex	ATR-124	ATR-124	<b>ATR-124</b>
71C039	Ampex	MM-1200	MM-1200	<b>MM-1200</b>
71C062	Ampex	VPR-3 VPR-6 VPR-80 VPR-300	VPR-3 VPR-6 VPR-80 VPR-300	<b>Micro Lynx Serial</b>
71C076	Denon	DN-3603 RA	DN-3603 RA	<b>DEN-3603</b>
	Denon	DN-3603G	DN-3603G 10k	
71C081	Fostex	Model 20	Model 20	<b>Model 20</b>
71C062	Fostex	D-20 RD-8	D-20 RD-8	<b>Micro Lynx Serial</b>
71C040	Fostex	E-2 E-8 E-16 E-22 G-16 G-24	E-16	<b>E &amp; G Series</b>
71C062	JVC	CR-850	CR-850, Ser	<b>Micro Lynx Serial</b>
71C042 or 71C073	JVC	BR-610 BR-611	BRS-610	<b>JVC Type B or JVC Type B (Y Cable)</b>
		BR-810 BR-811	BRS-810	
		BR-5610 BR-5810 BR-8600U BR-7700U	BR-8600 "B" cbl	
		BR-8600E BR-7700E	BR-8600E	
71C043 or 71C070	JVC	CR-5500 CR-6650 CR-8250	CR-8250	<b>JVC Type C or JVC Type C (Y Cable)</b>
Special Order	3M	M-79	M-79	<b>M79</b> (Dealer installation recommended)
71C046	Mitsubishi	X-850	X-850, Capst-Norm X-850, Capst-Rls-Norm	<b>X-850</b>
		X-880	X-880, Capst-Norm X-880, Capst-Rls-Norm	

**Table A-3. Cable Reference Guide (continued)**

<b>Micro Lynx Transport Control Cables</b>				
<b>Timeline Part No.</b>	<b>Transport Manufacturer</b>	<b>Machine Model</b>	<b>Setup Menu Description</b>	<b>Cable Type Description</b>
71C047	Otari	MTR-10/1 MTR-12/1	MTR-10/1 MTR-12/1	<b>MTR-10/12</b> , Series I (20-pin Honda connectors)
71C048	Otari	MTR-90/1	MTR-90/1	<b>MTR-90</b> , Series I (50-pin & 9-pin "D" connector) (Y Cable)
71C064	Otari	MTR-90/2 MTR-90/2 Layback MTR-90/3	MTR-90/2 MTR-90/2 Layback MTR-90/2, Srch-V	<b>MTR-90</b> , Series II (25-pin Honda connector)
71C066	Otari	MTR-100	MTR-100	<b>MTR-100</b>
71C063	Otari	MTR-10/2 MTR-12/2 MTR-20 MTR-15 MX-55 MX-70 MX-80 MX-70 Layback MTR-100 MTR-100V	MTR-10/2 MTR-12/2 MTR-20 MTR-15 MX-55 MX-70 MX-70 MX-70 Layback MTR-100 MTR-100, Srch-V	<b>Otari Type A</b>
		DTR-900/1	DTR-900/1, Capst-Norm DTR-900/1, Capst-Rls	
		DTR-900/2	DTR-900/2, Capst-Norm DTR-900/2, Capst-Rls	
71C049	Otari	MX-5050/3	MX-5050/3	<b>MX-5050 MkIII</b> Series, 16-pin (older machines)
71C050	Otari	MX-5050/3	MX-5050/3	<b>MX-5050 MkIII</b> Series, 34-pin (current machines)
71C051	Otari	MX-5050/3	MX-5050/3	<b>MX-5050 MkIII</b> Series, 34-pin "Y" (current machines) (Y Cable)
71C062	Otari	DTR-90	DTR-90	<b>Micro Lynx Serial</b>
71C062	Panasonic	AG-7750 AG-7700	AG-7750	<b>Micro Lynx Serial</b>
		AJ-D350	AJ-D350	
71C071	Saturn	824	824	<b>824</b> (a.k.a. Soundcraft Saturn)
71C052	Sony	PCM-3402	3402, Par Capst-Norm 3402, Par Capst-Rls 3402, Ser/Par Capst-Norm 3402, Ser/Par Capst-Rls	<b>Sony Type A</b>
		APR-24 APR-5000	APR-24 APR-5000	
No longer available	Sony	BVU-800	BVU-800, Par	<b>BVU-800</b> (Parallel interface)
71C054 or 71C069	Sony	JH-24 JH-114 Late Model JH-16	JH-24 / JH-110	<b>JH-24 or JH-24</b> (Machines with 12-pin "Autolocator" connector) (Y Cable)
71C055 or 71C074	Sony	JH-110 ABC JH-114 Early Model	JH--114	<b>JH-110 or JH-110</b> (Machines with 21-pin "Synchronizer" connector) (Y Cable)
71C056	Sony	PCM-3324	PCM-3324, Capst-Norm-Hi-Prec PCM-3324, Capst-Rls	<b>PCM-3324</b>
		PCM-3324S	PCM-3324s, Capst-Norm-Hi-Prec PCM-3324s, Capst-Rls	
71391	Sony	PCM-7030fm	PCM-7030/fm	<b>PCM-7030 FM</b> (Vari-speed operation)

Table A-3. Cable Reference Guide (continued)

<b>Micro Lynx Transport Control Cables</b>				
<b>TimeLine Part No.</b>	<b>Transport Manufacturer</b>	<b>Machine Model</b>	<b>Setup Menu Description</b>	<b>Cable Type Description</b>
71C075	Sony	VO-5850	VO-5850 int	<b>VO-5850</b> (M3 Card required)
71C062	Sony	PCM-7030 PCM-7050	PCM-7030	<b>Micro Lynx Serial</b>
		VO-9800 VO-9850	VO-9800	
		BVW-10 BVW-40 BVW-75	BVM-10 BVW-40 BVW-75	
		BVU-800	BVU-800, Ser	
		BVU-950	BVU-950	
		BVH-2000 BVH-2800 BVH-3000	BVH-2000	
		DMR-4000	DMR-4000	
		DVR-10/18 DVR-1000	DVR-10 DVR-1000	
		DVW-500 DVW-A500 DVW-510 DVW-A510 DVW-CA510 DVW-CA510	DVW-500	
		UVW-1800	UVW-1800	
Special Order	Stellavox	TD-9	TD-9	<b>TD-9</b>
71C067	Studer	A-807	A-807, Par A-807, Ser/Par	<b>Studer Type B</b>
		A-810	A-810	
		A-812	A-812, Par A-812, Ser/Par	
		A-820 1/2"	A-820 1/2", Par A-820 1/2", Ser/Par	
		A-820 32 Hz	A-820, Par A-820, Ser/Par	
		A-827 32 Hz	A-827 32 Hz Tach, Par A-827 32 Hz Tach, Ser/Par	
		D-820 64 Hz	D-820 64 Hz/48k, Par Capst-Norm D-820 64 Hz/44.1k, Par Capst-Norm D-820 64 Hz/48k, Par Capst-Rls D-820 64 Hz/44.1k, Par Capst-Rls	
		D-827 64 Hz	D-827 64 Hz/48k, Par Capst-Rls D-827 64 Hz/44.1k, Par Capst-Rls	
71C058	Studer	A-80VU	A80VU 16 Hz Tach A80VU 18 Hz Tach	<b>A-80VU</b>
71C059	Studer	A-800/1 A-800/3	A-800/1 A-800/3	<b>A800</b>
71C062	Studer	D-827	D-827	<b>Micro Lynx Serial</b>
71C060	Tascam	40 Series	40 Series	<b>Tascam Type A</b>

Table A-3. Cable Reference Guide (continued)

<b>Micro Lynx Transport Control Cables</b>				
<i>TimeLine Part No.</i>	<i>Transport Manufacturer</i>	<i>Machine Model</i>	<i>Setup Menu Description</i>	<i>Cable Type Description</i>
		ATR-60 ATR-80	60 Series ATR-80	
71C068	Tascam	MSR-16 MSR-24 BR-20T	MSR-16	<b>Tascam Type B</b>
		TSR-8	TSR-8	
71C061	Tascam	50 Series	50 Series	<b>50 Series</b>
71C062	Tascam	DA-88	DA-88	<b>Micro Lynx Serial</b>
		DA-60	DA-60	
Special Order	Tascam	DA-800	DA-800 44.1k DA-800 48k	<b>DA-800</b>

# Auto Serial Transport

A new transport selection labeled "AUTO Serial TRANSPORT" will automatically detect the presence of most serial transports, and load in the appropriate transport parameters. The following table lists the serially controlled transports currently recognized, and shows the transport selection that will be invoked when each transport is found.

Serial Transport	TRAN Selection
Sony BVH-2000	SONY BVH-2000
Sony BVH-2180	SONY BVH-2000
Sony BVH-2500	SONY BVH-2000
Sony BVH-2700	SONY BVH-2000
Sony BVH-2800	SONY BVH-2000
Sony BVH-2830	SONY BVH-2000
Sony BVH-3000	SONY BVH-2000
Sony BVH-3100	SONY BVH-2000
Sony BVU-800	SONY BVU-800s
Sony BVU-820	SONY BVU-800s
Sony BVU-850	SONY BVU-800s
Sony BVU-870	SONY BVU-800s
Sony BVU-900	SONY BVU-950
Sony BVU-920	SONY BVU-950
Sony BVU-950	SONY BVU-950
Sony VO-9800	SONY 9800
Sony VO-9850	SONY 9800
Sony BVW-10	SONY BVW-10
Sony BVW-40	SONY BVW-40
Sony BVW-11	SONY BVW-10
Sony BVW-15	SONY BVW-10
Sony BVW-60	SONY BVW-75
Sony BVW-65	SONY BVW-75
Sony BVW-95	SONY BVW-75
Sony BVW-96	SONY BVW-75
Sony BVW-70	SONY BVW-75
Sony BVW-75	SONY BVW-75
Sony PVW-2600	SONY BVW-75
Sony PVW-2800	SONY BVW-75
Sony PVW-2650	SONY BVW-75
Sony BVW-D75	SONY BVW-75

Serial Transport	TRAN Selection
Sony DVR-1000	SONY DVR-1000
Sony DVR-2000	SONY DVR-1000
Sony DVR-2100	SONY DVR-1000
Sony DVR-10	SONY DVR-10
Sony DVR-18	SONY DVR-10
Sony DVR-20	SONY DVR-10
Sony DVR-28	SONY DVR-10
Sony DVW-500	SONY DVW-500
Sony PCM-3402	SONY 3402 sd
Sony PCM-7030	SONY 7030
Sony PCM-7050	SONY 7030
Sony EVO-9800	SONY 9800
Sony EVO-9850	SONY 9800
Alesis AI2	ALESIS AI2/ADAT
JVC CR-850	JVC CR-850s
JVC CR-600	JVC CR-850 s
Fostex D-20	FOSTEX D-20
Otari DTR-90	OTARI DTR-90
Panasonic AG-7750	PANA AG-7750
Panasonic AJ-D350	PANA AJ-D350
Tascam DA-88	TASCAM DA-88
Ampex VPR-80	AMPEX VPR-80
Ampex VPR-3	AMPEX VPR-3
Ampex VPR-6	AMPEX VPR-6
Ampex XVR-80	AMPEX VPR-80
Ampex VPR-300	AMPEX VPR-300
Ampex VPR-305	AMPEX VPR-300
Ampex VPR-350	AMPEX VPR-300
Ampex VPR-200	AMPEX VPR-300
Ampex VPR-250	AMPEX VPR-300
Ampex DCT-700d	AMPEX VPR-300



# Key and Key Combination Identification Numbers

## Micro Lynx

# on Screen	Stuck Key or Combination
0	0
1	1
2	2
3	3
4	4
5	5
6	6
7	7
8	8
9	9
10	00
11	CLR
12	MINUS (-)
13	PLUS (+)
14	EQUAL (=)
15	STO
16	RCL
17	CAPT
18	SUBFR
19	MACRO
20	TRIM OR LAST
24	A
25	B
26	C
27	TCG
28	MIDI
30	F1
31	F2
32	F3

# on Screen	Stuck Key or Combination
33	SETUP
34	ACG
35	SYS
36	TRAN
37	EVNT
38	LIST
39	MEM
42	GRP
43	SOLO
44	LOOP
45	RDY
46	TRKS
50	LOC
51	CUE
52	ALL STOP
53	ROLLBACK
54	REPLAY
55	EDIT
56	RW (<<)
57	FF (>>)
58	STOP (■)
59	PLAY (>)
60	REH
61	REC
62	JOG OR NEXT
63	SHTL OR ENTR
64	PEDAL
65	CUE + LOC
66	STOP + RW

Appendix

# on Screen	Stuck Key or Combination
67	STOP + FF
68	PLAY + REH
69	PLAY + REC
144	CLR + 0
145	CLR + 1
146	CLR + 2
147	CLR + 3
148	CLR + 4
149	CLR + 5
150	CLR + 6
151	CLR + 7
152	CLR + 8
153	CLR + 9
154	CLR + 00
157	CLR + CUE
158	CLR + EDIT
160	CLR + RDY
161	CLR + SYS
162	CLR + TRAN
163	CLR + TRKS
164	CLR + SETUP
165	GRP + SETUP
166	GRP + SYS
167	MEM + CAPT

# on Screen	Stuck Key or Combination
176	MACRO + 0
177	MACRO + 1
178	MACRO + 2
179	MACRO + 3
180	MACRO + 4
181	MACRO + 5
182	MACRO + 6
183	MACRO + 7
184	MACRO + 8
185	MACRO + 9
192	GRP + A
193	GRP + B
194	GRP + C
195	GRP + TCG
196	GRP + MIDI
200	RDY + A
201	RDY + B
202	RDY + C
208	SETUP + A
209	SETUP + B
210	SETUP + C
211	SETUP + TCG
212	SETUP + MIDI

## Glossary

---

- 24** '24' refers to both the film-standard speed and code type.
- 25** '25' refers to both the EBU/PAL speed and code type.
- 29.97** '29.97' refers to a SMPTE frame rate only, in frames-per-second.
- 30** '30' refers to a SMPTE frame rate only, in frames-per-second.
- Address** SMPTE/EBU time code address. Also referred to as time code value. A specific and unique address in the time code data stream.
- A set of SMPTE or EBU time code numbers indicating a specific position on tape. A complete SMPTE address includes hours, minutes, seconds, and frames.
- ADR** Automated Dialog Replacement. A technique for replacing production dialog in the studio.
- AES/EBU** A professional standard for the high speed transfer of two channels of digital audio data. Developed jointly by the Audio Engineering Society (AES) and the European Broadcast Union (EBU).
- Amplitude** Signal displacement from a zero point. The amplitude of an analog signal is the measurement of voltage increase or decrease.
- Analog Audio** The "traditional" means of recording and reproducing sound, using fluctuating electronic voltages to replicate audio waveforms.
- ATR** Audio Tape Recorder.
- Autolocator** A device that can hold multiple tape locations in memory and chase to those locations on command, using SMPTE addresses, tach pulses, or control track pulses to find a desired point on tape.
- Bandwidth** The frequency range of a signal.
- Binary Numerical System** A system for expressing numerical values using two digits, 0 and 1. The binary system is used in digital audio, SMPTE, MIDI, and other microprocessor-related data formats.

- Biphase Encoding** The way in which SMPTE time code gets encoded onto tape. It expresses binary '1' and binary '0'.  
Biphase encoding reverses the signal polarity halfway through a bit to represent a '1' and leaves the bit polarity unchanged to represent a '0'.
- BIT** Short for BInary digiT; a number which is either one or zero.
- Blanking Interval** The blanking interval occurs at the end of a frame. Video information is absent during the blanking interval. The interval occurs when the CRT electron gun scanner goes from the bottom right corner of the screen to the beginning of the next field in the top left corner.
- BNC** Bayonet-Nut Coupler. Used for the connection of video and high frequency clock signals.
- Byte** A group of related binary data or a word, which can be read, interpreted, and acted on by a microprocessor. A byte is made up of bits, which can be either a 0 or 1.
- Capstan** On a tape recorder the motor driven spindle that drives the tape across the heads. A synchronizer controls the capstan motor to keep the tape in sync.
- Code Type** See Time Code Type
- Configuration** See Setup Mode. The process of defining the user-selected operational parameters, such as defining a specific transport or lifter-defeat mode.
- Control Track** A synchronizing signal on the edge of a tape, which provides a reference for tracking control and tape speed.
- CPU** Central Processing Unit. A computers central microprocessor, responsible for all system logic and memory organization.
- DAW** Digital Audio Workstation. Usually refers to a computer-based, hard disk recording and editing environment.
- Decibel (dB)** The unit of measurement used to describe a sounds amplitude. The measurement is relative and logarithmic.
- DF** Drop frame. See drop frame
- Differential Input** Input amplifier that is designed to amplify the difference between two signals and reject common signals.
- Differential Output** Output amplifier designed to provide two signals that are completely identical but with opposite phase.

- Digital** Literally “using digits”. A Computer is a typical digital device.
- Digital Audio** Audio signal that has been converted (digitized) into a stream of binary numbers for storing or transmitting, that are equivalent to the original analog audio signal.
- Display** Numeric display. Time Code/Message Display.
- Drop Frame** Drop frame is one of the two SMPTE code types, and is the NTSC color television standard. When using this code type, 108 specific frame numbers are “dropped” for each hour of time code. See the Appendix for more detailed time code information.
- EBU** EBU time code is a 25-frame code running at 25 fps.
- Edit Decision List (EDL)** A list, either on paper or in computer memory, of time code addresses indicating successive scenes of source video footage that make up a complete program.
- EDL** See Edit Decision List.
- ERR** Error or offset error. Indicates that the display shows the difference between the actual position of the machine in relation to where the system expects it to be.
- EXT VID** A source of external video sync used by the synchronizer as a timing reference. Can be color black, black burst, color bars or composite sync.
- Filter** A digital or analog process which has the effect of removing unwanted frequencies from an audio signal.
- Foley** The process of adding incidental sounds, such a footsteps, door slams, etc., to a video program or motion picture.
- Format** See Time Code Format.
- Frame** A single image on a motion picture film or a television picture formed from two interlaced fields. One complete video scanning cycle, one complete SMPTE time code word.
- Frame Lock** Frame lock maintains synchronization between the Master and Slave transports, using the position information available in the time code address.
- Frame Rate** The number of frames that go by in one second of audio, film or video tape. Film and different types of video all have different frame rates.
- 30      30 fr/s      Monochrome TV, & audio

NTSC	29.97 fr/s	Color videotape, TV operations
PAL	25 fr/s	European TV, European Broadcast, & audio
Film	24 fr/s	Film cameras & projectors

- Frequency** The number of wave cycles that occur in a given period of time (one second). The unit of measurement is the Hertz (Hz).
- Generate** Running the system time code generator so that time code is available at the rear panel GEN OUT jack.
- Generator** A time code generator. Each synchronizer has a time code generator. This generator receives its speed reference from one of the internal or external sources.
- GEN REF** Generator reference. May also be referred to as reference source.
- Groups** A group of machines that have a defined positional relationship. Machines are placed in group mode for synchronization. Machines in a group will operate together as if they were a single transport.
- GRP** See Groups.
- Guard Band** A track of multitrack tape adjacent to the sync track (such as SMPTE or Control Track), which is left unrecorded in order to prevent the time code from bleeding onto the audio program material.
- HH:MM:SS:FF** Hours:Minutes:Seconds:Frames. A SMPTE time code address or value.
- Initialize** Completely clear the synchronizers RAM. Press and hold the CLR key while you power-up the module.
- INT XTAL** A system speed reference that is derived from the unit's internal crystal. This reference should be selected when an external reference (video or word clock) is not required.
- Jam Sync** A technique used to start a time code generator from another running time code. It can be used to recreate missing time code or to external existing time code on tape.
- Jam Time Code** The Jam Time Code or Jam Sync function. See Jam Sync.
- KCU** Keyboard Control Unit. TimeLine's external machine control unit. The KCU provides centrally-controlled access to all synchronizers in a system.
- LCD** Liquid Crystal display. The KBD display is of this type.
- LED** Light emitting diode.
- Lifter** A tape transport's head lifter mechanism. Tape machines

normally lift the tape off the heads when in wind (FFW/RWD). The synchronizer intelligently controls the machines lifter operation, to read time code when required.

- Local Transport** The machine or transport that the synchronizer is connected to and controlling.
- Lock** The transport is synchronized with the system reference GEN REF.
- LTC** Longitudinal Time Code. Time code information encoded in binary coded decimal (BCD) form which is recorded as an audio signal on a designated track of a VTR or an ATR.
- Machine** Machine refers to the generic concept of tape record/playback hardware.
- Machine Control** The wide ranging field of transport control. This covers basic transport operation, synchronization and more complex functions such as electronic editing.
- MACROS** Preprogrammed or user programmed keys permitting complex key sequences to be stored and executed by pressing a single key. Sometimes known as smart keys.
- MIDI** Musical Instrument Digital Interface. This serial data language is used by microprocessors in synthesizers, sequencers, drum machines, signal processors, and computers. It provides musical pitch and rhythm information, synthesizer performance parameters, song position markers, stop/start/continue commands for sequencers and computers, and synchronizing data called MIDI Clock, which is based on 24 pulses per quarter-note. MIDI is frequently used with SMPTE for sync-to-tape functions.
- MIDI is transmitted between microprocessors at 32.125 kBits per second. It can also be used by lighting systems and mixing consoles.
- MIDI Time Code** A MIDI system real time message that assigns a unique address for a specific moment in time. MIDI Time Code takes two frames to transmit a complete address in bursts of data that are transmitted every 1/4 frame.
- Motion Controls** The basic set of six transport control keys (Play, Stop, Rec, Reh, Rwd & FF) and the six additional transport control functions (Loc, Cue, Allstop, Rlb, replay & Edit).
- MTC** See MIDI Time Code.
- Multitrack** A tape machine, analog or digital which has more than two audio tracks.
- N/A** Not available. Not active. Not applicable.

- Non Drop Frame** NDF or ND is one of the two SMPTE code types and is the black & white television standard. When using this code type, every frame of time code is counted in real time. See the Appendix for more time code information.
- Non-contiguous** Not a continuous, predictable sequence. i.e., 1, 2, 4, 5, 6, 8, 9 is a non-contiguous number sequence.
- NTSC** A system of coding color information for television transmission used primarily in the USA and Japan. Named after the National Television System Committee.
- Offset** Offset is the difference between two time codes at the point at which they are to be synchronized. Offsets are subframe-accurate and are displayed using the HH:MM:SS:FF format. Offsets are always applied to the slave machines.
- Oversampling** A process by which a computer interpolates between adjacent digital audio numbers to provide in-between values and reduce quantization error.
- PAL** Phase Alternate Line. PAL is another name for the 25 time code format, which is the standard for European color and B&W television.
- Phase Lock** A mode of synchronizer operation that uses phase information derived from SMPTE time code and, after initial synchronization, ignores specific frame addresses. It is also called Sync Lock.
- Pilot Tone** The Pilot output signal is a sinusoidally-shaped output, which is always two times the frame rate of the time code that is being referenced or generated.
- Post-production** Activities that take place after the raw footage has been shot for a video program or motion picture. Includes video editing and a number of audio processes, such as ADR, Foley, and mixing.
- Production** The initial stages in the making of a film or television program, which includes the shooting of raw footage and recording of production audio.
- RAM** Random Access Memory. The module's configuration parameters are stored in battery-backed RAM. And recalled each time the unit is turned on.
- Rate** Frame rate or speed. See Frame Rate or Speed.
- REF SRC** Reference source. The signal that is used to determine the rate that the generator and synchronizer will run at. The reference source can be thought of as the system time base. The reference source can be internal crystal, external video, MAINS, or external

pilot tone or the time code reader (VSO).

- Register** The generator register is the module's memory buffer that holds numeric time code values that are entered or captured. Each synchronizer also has reader, sync point, offset, user bit and error registers.
- Reshape** The output signal is the same as the input signal, but it has been reshaped with correct rise time values and a fixed voltage output. This type of output does not correct for bit or timing errors.
- Resolving** A technique for regulating the play speed of a tape machine by matching the rate of pulses recorded on tape with a pulse rate from another stable source or a master tape machine.
- RLB** See Rollback.
- Rollback** The rollback function is used to rewind machines by a predetermined amount from the current position. The default rollback time is 15 seconds.
- S-PDIF** A consumer standard similar to AES/EBU for the high speed transmission of digital audio data. Jointly developed by Sony and Philips.
- Sequencer** A device that can record performance data for synthesizers and other electronic instruments and then, on playback, pass that data on to the instruments so that they'll play what has been recorded. Modern sequencers use MIDI as their communications protocol.
- Serial** A type of computer interface where all data is sent down a single wire or pair of wires one bit at a time. Examples of serial interfaces are RS422 & RS232.
- Serial Port** The physical computer connection through which serial data is transmitted and received.
- Setup Mode** The process of defining the user-selected operational parameters, such as defining a specific transport or lifter-defeat mode.
- Shuttle** Fast-wind. Fast-forward or Rewind.
- SMPTE** Society of Motion Picture and Television Engineers. An industry standards committee. The group responsible for developing SMPTE time code.
- SOLO** Literally "using alone". A tape transport in solo will be controlled by itself, without affecting other transports in the system.
- Speed** Speed, Frame Rate and Rate are synonymous. Time code speed is counted in frames-per-second (fps). SMPTE time code has two speeds: 30 fps and 29.97 fps.

- SU** See System Unit
- SUBF UBITS** Sub frame user bits.
- Sync Lock** See Phase Lock.
- Sync Word** Included at the end of every 80-bit time code word is a 16-bit Sync Word. The sync word provides direction and Phase-lock speed information, and marks the end of each time code word.
- Synchronizer** A device that reads time codes recorded on two or more tape machines, compares the codes, and adjusts the machine's tape positions and speeds based on the results of that comparison.
- System BUS** When two or more synchronizers are used to form a system, a communications link must be established between the modules. This is done by looping from one module to the next, via the RS422 ports on the rear panel of the system unit.
- System Unit** The rack mounting part of the Micro Lynx machine control system. The unit contains the control (CP) and machine control (MC) microprocessors.
- TCA** Time Code Address. The HH:MM:SS:FF bits of the TC word.
- TCG** See Time Code Generator.
- Time Code Format** Time code format defines both the frame rate and code type being used. Example: To describe a time code format as 30 NDF is to say that the frame rate is 30 fps and the code type is non-drop frame. Simply saying either 30 or drop frame defines only part of the SMPTE time code.
- Time Code Generator** A special signal generator designed to generate and transmit SMPTE time code at one of the international formats and rates.
- Time Code Reader** A counter designed to read and display SMPTE time code.
- Time Code Type** The word "type" is the key to understanding this phrase. *Type* defines the counting method that is employed by the time code module. There are two SMPTE types: 30 (also called non-drop "ND" or non-drop frame "NDF") and drop frame (DF). EBU and film types are the same as their respective speeds, 25 and 24.
- Toggle** To toggle is to consecutively press a key several times in order to step through a series of choices.
- Track** A place for the storage of audio information. Analog tape recorders have one or more physical tape tracks. MIDI sequencers and digital audio workstations provide areas of memory to store

- control or audio data.
- Track Select** The process of enabling (arming) specific tape machine tracks for recording.
- Transport** Transport refers to a part or subassembly of a machine, i.e., a transport connector or a transport cable.
- TRS** Tip - Ring - Sleeve. A 1/4", balanced termination plug or jack. Typically wired T = +, R = -, S = shield.
- Type** See Time Code Type.
- UB** See User Bit.
- User Bit** Each time code frame or word consists of 80 bits that convey SMPTE/EBU time code information. Thirty-two of those bits are user bits, and are available for storing information such as IDs, reel numbers, session dates or another time code number.
- Value** Values are generally time code addresses. They may also be a custom user bit IDs.
- Video Sync** A reference video signal generated by an extremely stable source. This signal is used to control the speed of video machines, digital audio machines and is used as a timing reference to ensure accurate synchronization.
- Virtual Tracks** Used to describe any circumstance whereby the method for reproducing audio tracks is not directly analogous to the linear tape track format. Hard disk systems (DAW's) and MIDI sequencers are typical examples.
- MIDI performance commands can be stored in a sequencer. Because the sequencer can "play" these parts in real time, synchronized to tape, they can be regarded as extra or "virtual" tracks, not on the tape, but present nonetheless.
- VITC** Vertical Interval Time Code. An alternative to the LTC format of SMPTE time code. It is recorded in the blanking interval of the video signal, which is not used for the picture.
- VSO** Variable Speed Override. Variable Speed Oscillator.
- VTR** Video Tape Recorder.
- Wideband** A signal that is distributed over most or all of the frequency spectrum. A wide band input amplifier is capable of processing signals that are well outside the audio bandwidth.
- Word Clock** An extremely stable synchronization signal that is used to control

the rate at which digital audio data is converted or transmitted.

**Workstation** See DAW.





# Index

- Key.....	8-55
+ Key.....	8-54
+/- IN LED.....	8-61
+/- OUT LED.....	8-61
= Key.....	8-54
0 TIME/VID Key.....	8-41
00 Key.....	8-39
1 PRE/A1 Key.....	8-42
2 POST/A2 Key.....	8-42
3 REF/A3 Key.....	8-43
4 SYNCP/A4 Key.....	8-43
5 OFST/CUE Key.....	8-45
6 ERR/TC Key.....	8-47
7 IN Key.....	8-48
8 OUT Key.....	8-48
9 DUR/ASM Key.....	8-48

## A

A1 Key.....	8-42
A2 Key.....	8-42
A3 Key.....	8-43
A4 Key.....	8-44
A-C Keys.....	8-28
2-1, 2-7, 7-2	
2-1	
Audio Clock Generator.....	9-15
2-1, 2-7, 2-8	
2-1, 2-7	
Purpose.....	9-16
ACG Card.....	10-1, 10-12
ACG Key.....	8-18, 8-20
AES/EBU time code.....	9-15
ALL STOP Key.....	8-11
ASM Key.....	8-49
Assemble Function.....	8-49
Audio Clock Generator.....	2-1, 10-1, 10-12
Audio Clock Generator Options.....	8-18, 8-20
Audio Clock, setting up with Micro Lynx.....	9-20
Audio Only Studio.....	6-3
Audio/Video Production.....	6-5
AudioVision.....	9-1, 9-3
Auxiliary Function Keys.....	8-50
AVID.....	9-1

Micro Lynx  
06/22/00

## B

Boot System Unit.....	8-21
BUSY LED.....	8-29

## C

Cables.....	1-9, 3-1, 3-4
Calculator Keys	
0 TIME/VID.....	8-41
00 key.....	8-39
1 PRE/A1.....	8-42
2 POST/A2.....	8-42
3 REF/A3.....	8-43
4 SYNCP/A4.....	8-43
5 OFST/CUE.....	8-45
6 ERR/TC.....	8-47
7 IN.....	8-48
8 OUT key.....	8-48
9 DUR/ASM.....	8-48
Accessing registers.....	8-8
CLR key.....	8-39
Equal key.....	8-54
Minus key.....	8-55
Plus key.....	8-54
Calculator Scratch Pad.....	4-21, 8-5, 8-7
Capstan Mode.....	8-23
Capstan Speed.....	8-23
CAPT Key.....	8-53
Changing Master Machine.....	4-17
Changing Memory Size.....	8-27
Chase mode	
with Micro Lynx.....	9-17
2-7	
CLR Key.....	4-21, 8-39
Components.....	1-2
Configuration.....	1-3
Connectors	
For house sync.....	6-5
Keyboard.....	7-8
MAC.....	7-7
MIDI.....	7-6
RS232/422.....	7-7

## Index

Time code generator ..... 7-5  
Transport..... 7-4  
Controlling system with Micro Lynx..... 9-15  
CUE Key .....6-8, 8-11, 8-12, 8-46  
Cue Points ..... 6-8, 8-52  
CUE Register ..... 6-8

### D

Device Select Keys..... 8-18  
ACG..... 8-20  
EVNT ..... 8-25  
LIST..... 8-27  
MEM..... 8-27  
SETUP..... 8-18  
SYS..... 8-20  
TRAN ..... 8-21  
Digital Audio Clock Generator ..... 2-1, 10-12  
Digital Audio Clock Generator Card..... 10-1  
Digital Audio Clock Generator, LEDs ..... 8-60  
2-7  
Display Mnemonics..... 8-5  
Display Screen ..... 8-4  
Displaying  
Calculator data ..... 8-5  
Errors ..... 8-10  
Machine information..... 8-5  
Machine status ..... 8-5  
Prompts ..... 8-10  
Time Code ..... 8-5  
Drop Frame Code..... 8-5, 8-46  
Dropouts, Recovery..... 6-6, 6-7  
DUR Key..... 8-48  
Duration Register, Accessing ..... 8-48

### E

Edit In Point ..... 8-48  
EDIT Key..... 8-12, 8-18  
Edit Loop ..... 6-12  
Edit Options ..... 8-18  
Editing..... 4-18  
ENTR Key..... 8-17  
Equal Key..... 8-54  
ERR Key ..... 8-47  
Error Messages..... 5-5  
Error Register..... 8-47  
Errors  
Accessing error register ..... 8-47  
ACG operations ..... 10-21  
Displaying..... 5-1, 8-20  
Register status by mode ..... 8-47  
VSG or System ..... 8-59  
When system error occurs..... 8-20

Event Options .....8-18, 8-27  
EVNT Key.....8-18, 8-25  
External Computer..... 7-2  
External Video..... 6-19

### F

F1 Key ..... 8-20  
F2 Key ..... 8-20  
F3 Key ..... 8-20  
FAST FORWARD Key..... 8-13  
Film Frame Rate ..... 6-2  
Footswitch Recording ..... 6-13  
Frame rate  
Setting with Micro Lynx..... 9-23  
System ..... 9-17  
with MTC ..... 9-22  
Frame Rate  
Default..... 4-5  
Displaying ..... 6-2  
Matching to video..... 6-5  
Fuses ..... 3-3

### G

Generating Time Code..... 4-7  
GPI  
Duration register..... 8-25  
Preroll register..... 8-25  
Relays, accessing..... 8-25  
Select options ..... 8-18  
Transport keys ..... 8-25  
GPI Closures..... 8-25  
2-4  
Group Editing ..... 6-12  
Group Mode ..... 6-9  
Group Options ..... 8-18, 8-31  
Group Select Keys  
A-C..... 8-28  
GRP..... 8-31  
LOOP ..... 8-34  
MIDI ..... 8-28, 8-30  
RDY ..... 8-35  
SOLO ..... 8-28, 8-34  
TCG..... 8-28, 8-29  
TRKS ..... 8-35  
Grouping Machines ..... 4-10, 4-11, 6-9  
GRP Key..... 8-18, 8-31  
GRP LEDs ..... 8-32

### H

Hardware Supplied ..... 3-1  
Harmonics..... 6-3

House Sync .....6-5

**I**

IN 1470/1764 LED .....8-60  
 IN 1600/1920 LED .....8-60  
 IN Key.....8-48  
 In Point Register, Accessing .....8-48  
 In Point Short Cut Keys .....8-20  
 Input  
   MIDI.....7-6  
   Time Code .....7-5  
   Transport .....7-4  
   Video Sync .....7-3  
 Installing Micro Lynx System Hardware.....3-1  
 Installing Options  
   ACG Card..... 10-21, 10-24  
   M3 Card.....10-7  
   VITC Card..... 10-28, 10-30  
   VSG Card .....10-2

**J**

Jam Sync ..... 6-3, 6-7  
 JOG Key.....8-17  
 Jog Mode..... 8-16, 8-17  
 Jog Wheel .....8-16

**K**

2-8  
 Keyboard Connector .....7-8  
 Keyboard Controller ..... 1-3, 1-4, 6-1, 8-1  
   Resetting .....4-22  
 KEYBOARD LED.....7-2  
 Keyboard Operations .....6-14

**L**

LAST Key ..... 8-17, 8-18  
 LED  
   +/- IN .....8-61  
   +/- OUT .....8-61  
   ACG.....7-2  
   BUSY .....8-29  
   Computer .....7-2  
   IN 1460/1764.....8-60  
   In 1600/1920.....8-60  
   Keyboard .....7-2  
   LOCK .....8-29  
   M3 ..... 7-2, 10-4  
   MIDI.....7-2  
   MIXED CODE .....8-58  
   NON STD IN.....8-60  
   NON STD OUT.....8-61

OUT 1470/1764 ..... 8-60  
 OUT 1600/1920 ..... 8-60  
 Power ..... 7-3  
 REC.....8-15, 8-29  
 REF LOCK ..... 8-58  
 REH ..... 8-14  
 SYS ..... 8-20  
 System..... 7-3  
 VIDEO GEN ..... 8-58  
 VITC ..... 7-2, 8-59

**LEDs**

As status indicators ..... 8-58  
 Digital audio clock generator ..... 8-60  
 Front Panel ..... 7-2  
 Group ..... 8-32  
 System.....8-20, 8-58  
 Lifters, Defeating..... 8-24  
 LIST Key ..... 8-27  
 LOC Key ..... 8-11  
 LOCK LED ..... 8-29  
 Locking Machines ..... 4-11  
 Longitudinal Time Code..... 8-24, 10-27  
 LOOP Key.....8-18, 8-34  
 Loop Options..... 8-18  
 Loop Play ..... 6-12

**M**

2-1, 10-4  
   2-1, 2-6  
 M3 Card..... 10-1  
 M3 LED..... 10-4  
 MAC Connector ..... 7-7  
 Machine Information Display ..... 8-5  
 Machine Select Options..... 8-18  
 Machine Start Point ..... 6-8  
 Machine Status Display ..... 8-5  
 Macro  
   Defined.....6-15, 8-52  
   Deleting..... 6-17  
   Preprogrammed ..... 6-17  
   Programming..... 6-17  
   Setting up ..... 8-52  
   Short Cut Keys ..... 8-20  
 MACRO Key ..... 8-18, 8-52  
 Master Machine ..... 6-10, 6-19  
   Changing ..... 4-17  
 Mediasound  
   Synchronized with Micro Lynx ..... 9-15  
   Using with Micro Lynx ..... 9-16  
 MEM Key.....8-18, 8-27  
 Memory  
   Changing size ..... 8-27

## Index

Options..... 8-18  
Recalling a value..... 4-9, 6-15, 8-27  
Registers ..... 6-14, 8-27  
Storing to a location..... 4-9, 6-15, 8-27, 8-51, 8-53  
Micro Lynx..... 6-1  
Code only operation..... 6-19  
Components ..... 1-2, 2-3  
Connection to VTR..... 9-19  
Controlling Mediasound ..... 9-24  
Controlling multiple devices ..... 9-3  
Controlling one device..... 9-2  
Controlling one transport ..... 9-25  
Customizing ..... 4-23, 8-9  
Defined ..... 1-1, 9-15  
Expanding to three machines ..... 10-4  
Front Panel..... 7-2  
Getting Started ..... 4-1  
Keyboard Controller ..... 6-1  
MIDI features..... 7-2, 9-11  
Synchronized with Mediasound ..... 9-15  
System configuration ..... 1-3  
System Unit..... 6-1  
Using with Mediasound ..... 9-16  
With AudioVision ..... 9-3  
With Pro Tools..... 9-4  
  
Data source ..... 9-22  
MTC output ..... 9-16  
MTC synchronizing ..... 9-16  
MTC transmitted..... 9-26  
Time code setup..... 9-21  
    2-5, 2-8  
MIDI connector..... 7-6  
MIDI Key..... 8-18, 8-28, 8-30  
MIDI Options..... 8-18, 9-11  
MIDI Setup ..... 7-2  
MIDI with Micro Lynx..... 2-5  
Minus Key..... 8-55  
Mixed Code..... 8-46  
MIXED CODE LED ..... 8-58

### N

NEXT Key ..... 8-17, 8-18  
NON STD IN LED..... 8-60  
NON STD OUT LED..... 8-61  
Non-drop Frame Code..... 8-46  
NTSC ..... 7-3, 10-2

### O

Offset Register, Accessing ..... 8-45  
Offsets  
    Adjusting between machines..... 8-57

Calculating ..... 8-43, 8-45  
Displaying ..... 8-50  
Machine..... 6-11  
Recalling ..... 8-45  
Setting ..... 4-12, 6-11  
Storing ..... 8-45  
Trimming..... 4-16, 8-57  
OFST Key..... 8-45  
Operating Parameters..... 8-21  
Option Card  
    ACG ..... 2-7  
    Digital Audio Clock Generator ..... 2-1, 10-1, 10-12  
    Third Machine..... 2-1, 2-6, 10-1, 10-4  
    Video Sync Generator ..... 2-2, 10-1  
    VITC Reader ..... 2-2, 10-1, 10-27  
    VSG..... 10-2  
OUT 1470/1764 LED ..... 8-60  
OUT 1600/1920 LED ..... 8-60  
OUT Key ..... 8-48  
Out Point Register, Accessing ..... 8-48  
Out Point Short Cut Keys ..... 8-20  
Output  
    ACG Card..... 10-19  
    MIDI ..... 7-6, 9-16  
    time Code ..... 7-5  
    Transport ..... 7-4  
    Video Sync ..... 7-3

### P

PAL ..... 7-3, 10-2  
PLAY Key ..... 8-13  
Playback, Variable Speed ..... 6-18  
Plus Key..... 8-54  
POST Key..... 8-42  
Postroll Register, Accessing ..... 8-42  
Postroll, Adjusting ..... 6-12  
POWER LED ..... 7-3  
Power Supply..... 1-8, 3-1, 3-2  
PRE Key ..... 8-42  
Preroll Register, Accessing ..... 8-42  
Preroll, Adjusting..... 6-12  
Preroll, Creating ..... 6-5  
Pro Tools ..... 9-4, 9-9  
Procedure  
    Changing register values ..... 8-55, 8-56  
    Changing the master machine..... 4-17  
    Changing the reference machine ..... 4-17  
    Configuring Pro Tools as master..... 9-9  
    Configuring Pro Tools as slaves..... 9-5  
    Controlling a transport device ..... 9-2  
    Customizing Micro Lynx..... 8-9  
    Displaying messages ..... 8-10

- Editing .....4-18
  - Generating time code .....4-7
  - Grouping machines .....4-10, 4-11, 8-31
  - Recalling register values .....8-8, 8-50
  - Record enabling a track .....8-36
  - Setting and clearing sync points .....8-44
  - Setting system timing parameters .....4-5
  - Storing a value to a register .....6-15, 8-51, 8-53
  - Storing values in memory .....4-9
  - Trimming subframe information .....8-57
  - Turn on (power up) .....4-1
  - Video transport assemble .....8-49
  - Working with macros .....4-7, 8-52
  - Working with offsets .....4-13, 4-16, 8-45
  - Prompts .....5-9
  - Prompts, Displaying .....8-10
  - Punch In .....6-13
  - Punch Out .....6-13
- R**
- RCL Key .....8-8, 8-50
  - RDY Key .....8-18, 8-35
  - REC Key .....8-12, 8-14, 8-18
  - REC LED .....8-15, 8-29
  - Record Enable
    - A1 track .....8-42
    - A2 track .....8-42
    - A3 track .....8-43
    - A4 track .....8-44
    - Audio machines .....8-36
    - Cue track .....8-46
    - Multitrack machines .....8-36
    - Resetting .....4-21
    - Time code track .....8-47
    - Video transport .....8-36
  - Record Options .....8-18
  - Record Ready .....6-13
  - Recording
    - Punch in, punch out .....6-13
    - Setting options .....6-13
    - With footswitch .....6-13
  - REF Key .....8-43
  - REF LOCK LED .....8-58
  - Reference Machine .....6-10
  - Reference Sync Point Register, Accessing .....8-43
  - Registers
    - Accessing .....6-15, 8-8
    - Clearing .....8-39, 8-48
    - Memory .....6-14, 8-27
    - Recalling values .....8-8, 8-50
    - Storing values .....8-8, 8-51, 8-53
    - Trimming values .....8-16, 8-55, 8-56
  - REH Key .....8-12, 8-14, 8-18
  - REH LED .....8-14
  - Rehearse Options .....8-18
  - REPLAY Key .....8-12
  - Reset
    - Group status .....6-10
    - Keyboard Controller .....4-21
    - Machine Select Key .....8-22
    - Machine to default parameters .....4-22
    - System Unit .....4-21, 8-21
    - Track record enables .....4-21
- 2-4
- REWIND Key .....8-13
  - ROLLBACK Key .....8-11, 8-18
  - Rollback Options .....8-18
  - RS232/422 Connector .....7-7
- S**
- Sample rate
    - Parameters .....9-17
    - Setting for system .....9-20
    - with MTC .....9-22
  - 2-1
  - Select GPI Options .....8-18
  - Self Test Messages .....5-4
  - Serial Time Code .....8-24
  - Setting Machine Offsets .....6-11
  - Setting Time Code .....6-2
  - SETUP Key .....4-24, 8-18
  - Setup Parameters .....2-3, 4-24
  - SGI ports
    - Digital I/O .....9-15
    - Serial Port 2 .....9-18
  - SGI Workstation
    - Digital Audio output .....9-18
  - SHTL Key .....8-17
  - Shuttle Mode .....8-16
  - Shuttle Wheel .....8-16, 8-17
  - Slave machine .....9-15
  - SMPTE time code .....9-15
  - SMPTE Time Code .....6-2
  - SMPTE, Synchronizing .....9-16
  - Software Version Number .....8-20
  - SOLO Key .....8-28, 8-34
  - Solo Mode .....6-7
  - Sony VO-5850 .....2-6, 10-4
  - Source Sync Point Register, Accessing .....8-43
  - Specifications .....1-6
  - Start Point .....6-8, 6-11
  - Status
    - Current machine .....8-5, 8-21

## Index

---

Group Status Mode ..... 8-31  
Mode ..... 8-47  
STO Key ..... 8-8, 8-51  
STOP Key ..... 8-13  
Striping Time Code ..... 6-4, 6-17, 8-23, 8-52  
SUBFR Key ..... 8-57  
Subframe  
  Displaying errors ..... 8-47  
  Entering information ..... 8-57  
  Trimming information ..... 8-57  
Sync  
  with video ..... 9-15  
Sync Point  
  Clearing ..... 8-44  
  Displaying ..... 8-50  
  Reference register ..... 8-43  
  Setting ..... 8-44  
  Source register ..... 8-43  
Sync pulse generator (VSG card) ..... 9-15  
Synchronization, SMPTE ..... 6-2  
Synchronizing  
  Capstan mode ..... 8-23  
  Drop with non-drop ..... 8-46  
  Multiple machines ..... 6-9  
  Two audio tape machines ..... 6-3  
  Using control track data ..... 8-24  
  Using serial time code ..... 8-24  
  With Audio Clock Generator ..... 10-12  
SYNCP Key ..... 8-43  
SYS Key ..... 8-18, 8-20  
SYS LED ..... 8-10, 8-20  
System  
  Controlling with Micro Lynx ..... 9-15  
  Micro Lynx reference ..... 9-22  
  Setting sample rate ..... 9-20  
System configuration ..... 9-17  
System Error ..... 8-10, 8-20  
System Error Messages ..... 5-1  
SYSTEM LED ..... 7-3  
System Options ..... 4-24, 8-18, 8-21  
  2-1, 4-5  
System Unit ..... 1-3, 1-4, 3-1, 6-1, 7-1  
  2-1  
  Resetting ..... 4-21  
System, Resetting ..... 8-21

**T**

TC Key ..... 8-47  
TCG Key ..... 8-18, 8-28, 8-29  
TCG Options ..... 8-18  
Third Machine ..... 2-1, 2-6  
Third Machine Card ..... 10-1, 10-4

Time  
  Setting reference time base ..... 9-22  
Time code  
  Drop frame ..... 9-15  
  MIDI on Micro Lynx ..... 9-21  
  Non-drop frame ..... 9-15  
  Storing values ..... 8-8  
  Type parameters ..... 9-17  
  Type with MTC ..... 9-22  
Time Code  
  Calculating in mixed code ..... 8-46  
  Calculating offsets ..... 8-45  
  Capturing values ..... 8-53  
  Generating ..... 4-7  
  How to set ..... 6-2  
  Input/Output ..... 7-5  
  Longitudinal ..... 8-24, 10-27  
  Reading from tape ..... 8-24  
  Recalling stored values ..... 4-9, 8-8, 8-27, 8-50  
  Recovery from problems ..... 6-6  
  Selecting source ..... 6-19, 8-24  
  Serial ..... 8-24  
  SMPTE ..... 6-2  
  Storing values ..... 4-9, 8-51  
  TCG Options ..... 8-18  
  Track record enable ..... 8-47  
  Vertical ..... 10-27  
Time Code Display ..... 8-5  
Time Code Generator  
  Mode ..... 9-24  
  Play/Wind ..... 9-26  
  System Reference ..... 9-22  
  System Speed/Code Type ..... 9-23  
Time Code Generator Setup ..... 4-5  
TIME Key ..... 8-42  
Track Options ..... 8-18  
Tracks  
  Record Ready ..... 6-13  
  Safe mode ..... 6-14  
  Selecting ..... 6-14  
TRAN Key ..... 8-18, 8-21  
Transport  
  2-4  
  Customizing with M3 ..... 10-4  
  In code only ..... 6-20  
  Input/Output Port ..... 7-4  
  Installation ..... 9-25  
  Multiple machines ..... 6-9  
  Options ..... 8-18  
  Resetting parameters ..... 8-39  
  Selecting ..... 9-17



