

TEAC SCHEMATIC DIAGRAM (AMPLIFIER) X-3R

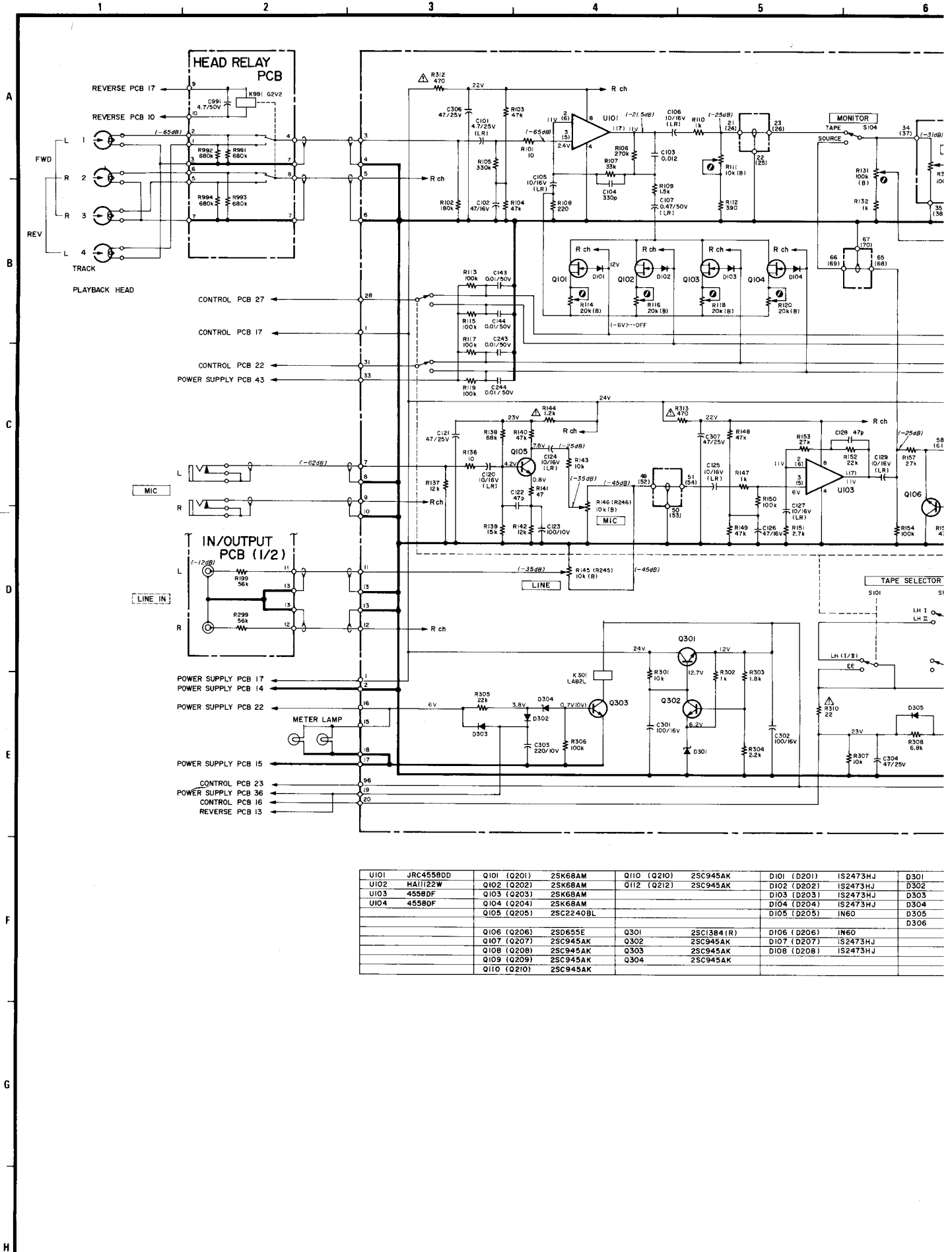

| | | | | | | | | |
|------|-----------|-------------|-----------|-------------|------------|-------------|----------|------|
| U101 | JRC4558DD | Q101 (Q201) | 2SK68AM | Q110 (Q210) | 2SC945AK | D101 (D201) | IS2473HJ | D301 |
| U102 | HA1122W | Q102 (Q202) | 2SK68AM | Q112 (Q212) | 2SC945AK | D102 (D202) | IS2473HJ | D302 |
| U103 | 4558DF | Q103 (Q203) | 2SK68AM | | | D103 (D203) | IS2473HJ | D303 |
| U104 | 4558DF | Q104 (Q204) | 2SK68AM | | | D104 (D204) | IS2473HJ | D304 |
| | | Q105 (Q205) | 2SC2240BL | | | D105 (D205) | IN60 | D305 |
| | | | | | | | | D306 |
| | | Q106 (Q206) | 2SD655E | Q301 | 2SC1384(R) | D106 (D206) | IN60 | |
| | | Q107 (Q207) | 2SC945AK | Q302 | 2SC945AK | D107 (D207) | IS2473HJ | |
| | | Q108 (Q208) | 2SC945AK | Q303 | 2SC945AK | D108 (D208) | IS2473HJ | |
| | | Q109 (Q209) | 2SC945AK | Q304 | 2SC945AK | | | |
| | | Q110 (Q210) | 2SC945AK | | | | | |

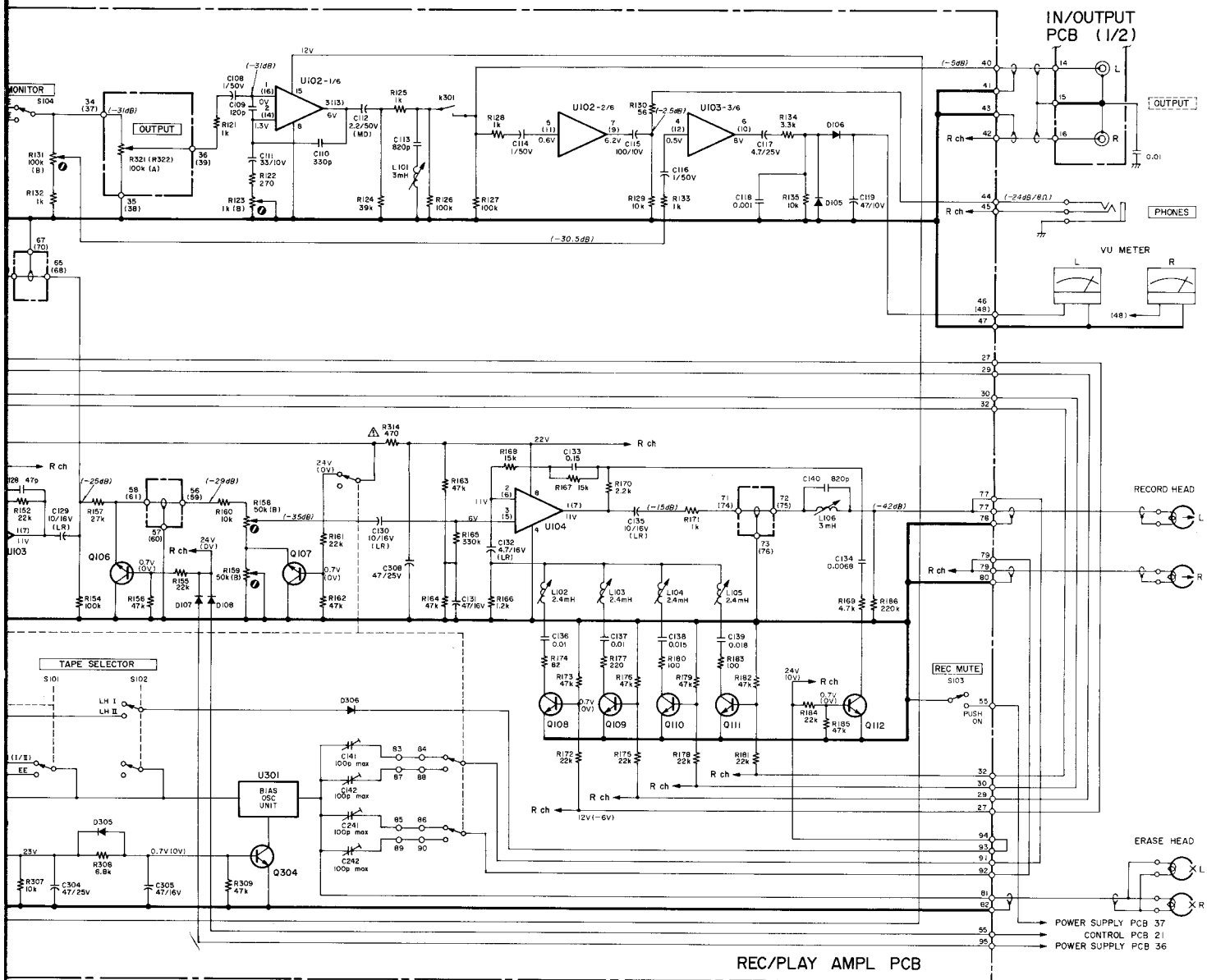

| | | |
|----------|------|----------|
| IS2473HJ | D301 | RD6.2EB |
| IS2473HJ | D302 | IS2473HJ |
| IS2473HJ | D303 | IS2473HJ |
| IS2473HJ | D304 | RD4.2EB |
| IN60 | D305 | IS2473HJ |
| IN60 | D306 | IS2473HJ |
| IS2473HJ | | |
| IS2473HJ | | |

- NOTES
- Schematic diagram shown for left channel except for some of the components.
 - All resistors are 1/4 watt, ±5%, unless marked otherwise. Resistor values are in ohms (k = 1,000 ohms).
 - All capacitor values are in microfarads (p = picofarads).
 - Parts marked with this sign are safety critical components. They must always be replaced with identical components—refer to the TEAC parts list and ensure exact replacement.
 - Voltage and level values are for reference only.
 - DC voltages were measured during REC/PAUSE mode unless otherwise noted.
 - 0 dB = 0.775V
 - +B power supply circuit
 - : front panel indication
 - : rear panel indication

X-3R
Stereo Tape Deck

1 2 3 4 5

A
B
C
D
E
F
G
H

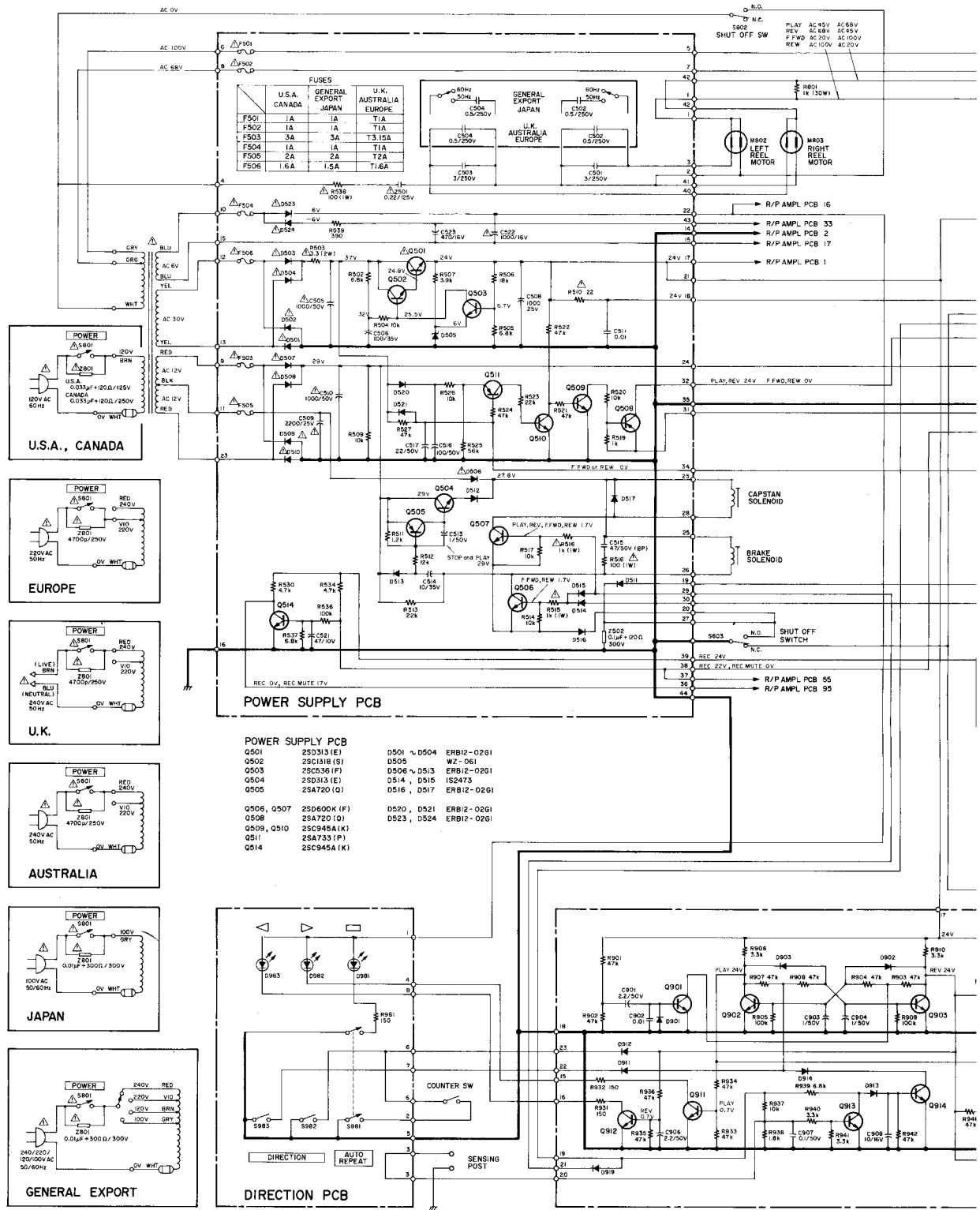

| FUSES | | U.S.A. CANADA | | GENERAL EXPORT JAPAN | | U.K. AUSTRALIA EUROPE | |
|-------|------|---------------|------|----------------------|------|-----------------------|--------|
| F501 | 1A | 1A | 1A | 1A | 1A | T1A | T1A |
| F502 | 1A | 1A | 1A | 1A | 1A | T1A | T1A |
| F503 | 3A | 3A | 3A | 3A | 3A | T3 15A | T3 15A |
| F504 | 1A | 1A | 1A | 1A | 1A | T1A | T1A |
| F505 | 2A | 2A | 2A | 2A | 2A | T2A | T2A |
| F506 | 1.6A | 1.6A | 1.6A | 1.6A | 1.6A | T1.6A | T1.6A |

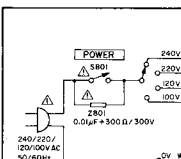
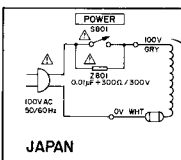
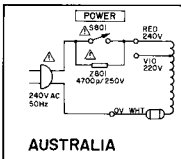
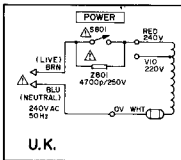
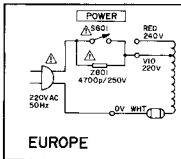
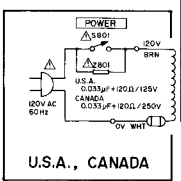

- POWER SUPPLY PCB**
- Q501 2SD313 (E)
 - Q502 2SD1318 (S)
 - Q503 2SC536 (F)
 - Q504 2SD313 (E)
 - Q505 2SA720 (Q)
 - Q506, Q507 2SD600K (F)
 - Q508 2SA720 (Q)
 - Q509, Q510 2SC945A (K)
 - Q511 2SA733 (P)
 - Q514 2SC945A (K)
 - D501 ~ D504 ERB12-0261
 - D505 WZ-061
 - D506 ~ D513 ERB12-0261
 - D514, D515 IS2473
 - D516, D517 ERB12-0261
 - D520, D521 ERB12-0261
 - D523, D524 ERB12-0261

DIRECTION PCB

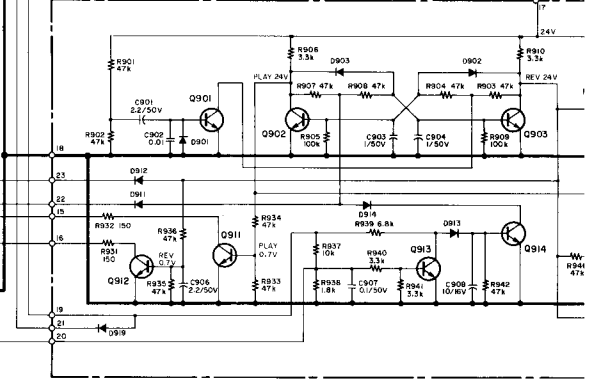

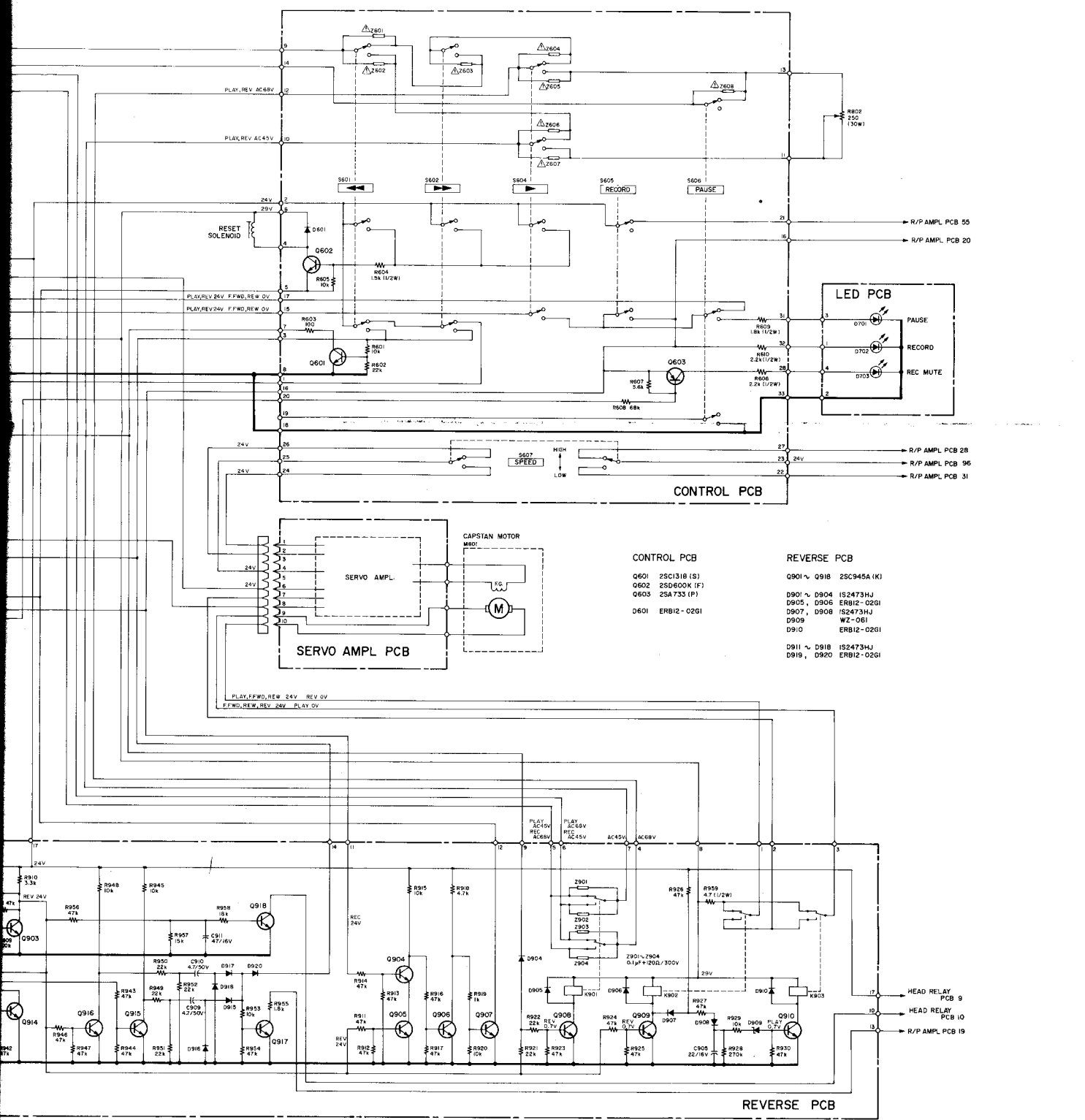

CONTROL PCB

Q601 2SC1318 (S)
 Q602 2SD600K (F)
 Q603 2SA733 (P)
 D601 ERB12-02G1

REVERSE PCB

Q901 ~ Q916 2SC945A (K)
 D901 ~ D904 IS2473HJ
 D905, D906 ERB12-02G1
 D907, D908 IS2473HJ
 D909 WZ-061
 D910 ERB12-02G1
 D911 ~ D918 IS2473HJ
 D919, D920 ERB12-02G1

- NOTES**
1. All resistors are 1/4 watt, ±5%, unless marked otherwise. Resistor values are in ohms (k = 1,000 ohms).
 2. All capacitor values are in microfarads (p = picofarads).
 3. ⚠: Parts marked with this sign are safety critical components, they must always be replaced with identical components—refer to the TEAC parts list and ensure exact replacement.
 4. DC voltages were measured during REC/PAUSE mode unless otherwise noted.
 5. —+B power supply circuit
 6. □: front panel indication
 □: rear panel indication

X-3R
 Stereo Tape Deck