

UNDERSTANDING, FINDING, & ELIMINATING GROUND LOOPS

CEDIA Class EST016

Instructor

Bill Whitlock

President & Chief Engineer
Jensen Transformers, Inc.
Chatsworth, CA

Bill Whitlock has designed pro audio-video electronics and systems since 1973. In 1989, after seven years with Capitol Records, he assumed presidency of Jensen Transformers. He has become a recognized expert on system interfacing issues through his writing and teaching. His landmark paper on balanced interfaces was published in the June 1995 AES Journal, which has since become the most popular ever printed. Other writing includes the popular "Clean Signals" column for S&VC magazine, the ongoing "Clear Path" column for Live Sound magazine, three chapters for Glen Ballou's 1500-page "Handbook for Sound Engineers," and numerous other magazine articles and Jensen application notes. Since 1994, he has helped thousands unravel the mysteries of grounding and signal interfacing by teaching at trade shows, universities, and professional organizations. Bill holds several patents including the InGenius® balanced input circuit and the ExactPower® waveform-correcting ac power voltage regulator. He is a Fellow of the Audio Engineering Society and a Senior Member of the Institute of Electrical and Electronic Engineers.

TABLE of CONTENTS

0 - INTRODUCTION	3
0.1 - How Quiet Is Quiet?	3
0.2 - Myths about Earth Grounding and Wires	3
1 - GROUNDING, AC POWER, AND SAFETY	5
1.1 - Protection from Defective Equipment	5
1.2 - Protection from Lightning	7
1.3 - The Facts of Life about AC Power	8
1.4 - It's Not Just 60 Hz	9
2 - UNBALANCED AUDIO INTERFACES	10
2.1 - Interfaces and Impedances	10
2.2 - Matching and Termination	11
2.3 - How the Noise Gets In	11
2.4 - Finding the Problem Interface	12
2.5 - Solutions	14
2.6 - Where to Break the Loop	17
2.7 - CATV and Satellite TV Dishes	18
2.8 - Isolation for Digital Interfaces	19
2.9 - Choosing Cables	19
2.10 - A Checklist	21
3 - BALANCED AUDIO INTERFACES	21
3.1 - A Question of Balance	21
3.2 - No Truth in Advertising	23
3.3 - Pin 1 Problems and the Hummer	23
3.4 - Finding the Problem Interface	24
3.5 - Solutions	25
3.6 - About Cables and Shield Connections	26
3.7 - Unbalanced to Balanced Interfaces	28
3.8 - Balanced to Unbalanced Interfaces	30
4 - VIDEO INTERFACES	31
4.1 - The "Hum Bar"	31
4.2 - Finding the Problem Interface	31
4.3 - Troubleshooting with a Clamp-On Ammeter	33
4.4 - Solutions	34
5 - RF INTERFERENCE AND POWER LINE TREATMENTS	38
5.1 - It Surrounds Us	38
5.2 - Squelching RF	38
5.3 - Technical Grounding	39
5.4 - Power Isolation, Filters, and "Balanced Power"	39
5.5 - Surge Suppression Cautions	40
REFERENCES	41
CONTACT INFO	43

0 - INTRODUCTION

“A cable is a source of potential trouble connecting two other sources of potential trouble.” This joke among electronic system engineers is worth keeping in mind. Any *signal* accumulates **noise** as it flows through the equipment and cables in a system. Once noise contaminates a signal, it's essentially impossible to remove it without altering or degrading the original signal. For this reason, no system can be quieter than its noisiest link. Noise and interference must be prevented along the entire signal path. Delivering a signal from one box to another may seem simple, but when it comes to noise, the signal **interface** is usually the danger zone, not the equipment's internal signal processing.

Many designers and installers of audio/video systems think of grounding and interfacing as a black art. How many times have you heard someone say that a cable is “picking up” noise — presumably from the air like a radio receiver? Or that the solution is “better” shielding? Even equipment manufacturers often don't have a clue what's **really** going on. The most basic rules of physics are routinely overlooked, ignored, or forgotten. College electrical engineering courses rarely even mention practical issues of grounding. *As a result, myth and misinformation have become epidemic!* This course intends to replace mystery with insight and knowledge.

0.1 - HOW QUIET IS QUIET?

How much noise and interference is tolerable depends on what the system is and how it's used. A monitor system in a recording studio obviously needs much more immunity to ground noise and interference than a construction site paging system. The *dynamic range* of a system is the ratio, generally measured in dB, of its maximum undistorted output signal to its residual output noise or *noise floor* — up to 120 dB of dynamic range may be required in high-performance sound systems in typical homes. [19] In video systems, a 50 dB signal-to-noise ratio is a generally accepted threshold beyond which no further improvement in images is perceivable, even by expert viewers.

Of course, a predictable amount of “white” noise is **inherent** in all electronic devices and must be expected. White noise is statistically random and its power is uniformly spread across the signal frequency range. In an audio system, it sounds like a “hiss.” In a video system, it appears as grainy movement or “snow” in the image. Excess random noise is generally due to improper gain structure, which will not be discussed here. Ground noise, usually heard as hum, buzz, clicks or pops in audio signals or seen as hum bars or specks in video signals, is generally much more noticeable and irritating.

10 dB noise reductions are generally described as “half as loud” and 2 or 3 dB reductions as “just noticeable.”

0.2 - MYTHS ABOUT EARTH GROUNDING AND WIRES

As electronics developed, the common return paths of various circuits were *also* referred to as “ground,” regardless of whether or not they were eventually connected to earth. In addition, a single ground circuit most often serves, either intentionally or accidentally, more than one purpose. Thus, the very meaning of the term **ground** has become vague, ambiguous, and often quite fanciful. Some engineers have a strong urge to reduce these unwanted voltage differences by “shorting them out” with massive conductors — the results are most often disappointing. [8] Other engineers think that system noise can be improved experimentally by simply finding a “better” or “quieter” ground. Many indulge in wishful thinking that noise currents can somehow be

skillfully directed to an **earth** ground, where they will disappear forever! [9] Here are some common myths about grounding:

Earth grounds are all at zero volts — presumably with respect to each other and to some “mystical absolute” reference point. This leads to whimsical ideas about lots of ground rods making system noises disappear! In fact, the soil resistance between ground rods is much higher (often tens of ohms) than a wire between them.

Note: **Impedance**, symbolized Z , is the apparent ac resistance of a circuit containing capacitance and/or inductance in addition to pure resistance.

Wires have zero impedance — and, therefore, can extend a zero-voltage reference to many locations in a system, eliminating voltage differences. In fact, wires are quite limited:

- The **DC resistance** of a wire applies only at very low frequencies and is directly proportional to its length. For example, the resistance of 10 feet of #12 gauge wire is about $0.015\ \Omega$.
- The **inductance** of a wire is nearly independent of its diameter (gauge) but is directly proportional to its length and increases at bends or loops. Our 10 feet of #12 gauge wire has an impedance of $30\ \Omega$ at 1 MHz (AM broadcast band) as shown in the graph. Substituting a $\frac{1}{2}$ -inch diameter solid copper rod lowers the impedance only slightly to about $25\ \Omega$.
- A wire resonates (becomes an antenna) when its physical length is a quarter wavelength. For a 10-foot wire, this means it will essentially become an open circuit at about 25 MHz.

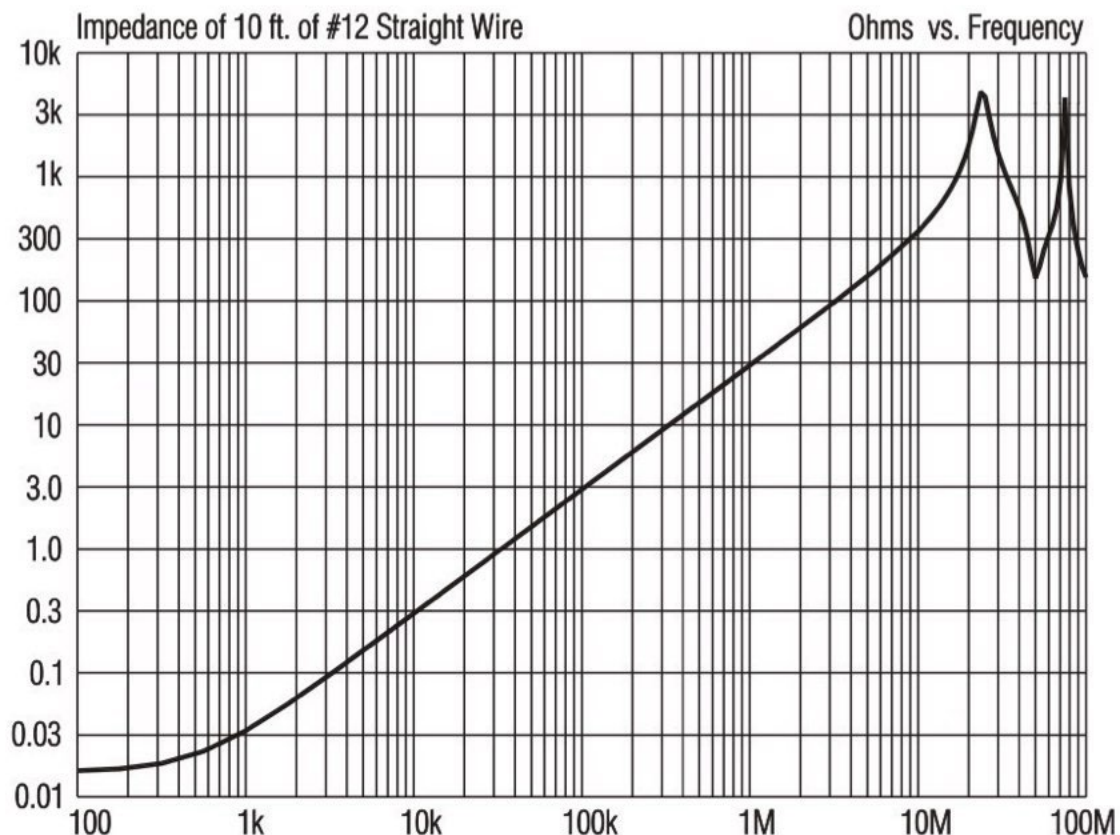

Are **EARTH** grounds necessary to prevent noise? Think about all the electronics in an airplane!

1 - GROUNDING, AC POWER, AND SAFETY

Broadly, the purpose of grounding is to electrically interconnect conductive objects, such as equipment, in order to minimize voltage differences between them. An excellent broad definition is that a **ground is simply a return path for current**. We must remember that **current always returns to its source** through either an intentional or accidental path - *electrons don't care and they don't read schematics!* [1]

The following drawing shows how ac power is supplied through a "three-wire service" to the load at an outlet (only two of the three are shown in the drawing for simplicity). One of the incoming service wires, which is often un-insulated, is the *grounded* or "neutral" conductor. National Electric Code requires that 120-volt ac power distribution (i.e., "branch circuits") in homes and buildings must be a 3-wire system. The neutral (white) and line (black) wires are part of the normal *load* current circuit shown by the arrows. Note that the neutral (white) and safety ground (green) wires of each branch circuit are tied or "bonded" to **each other** and to an earth ground rod at the service entrance.

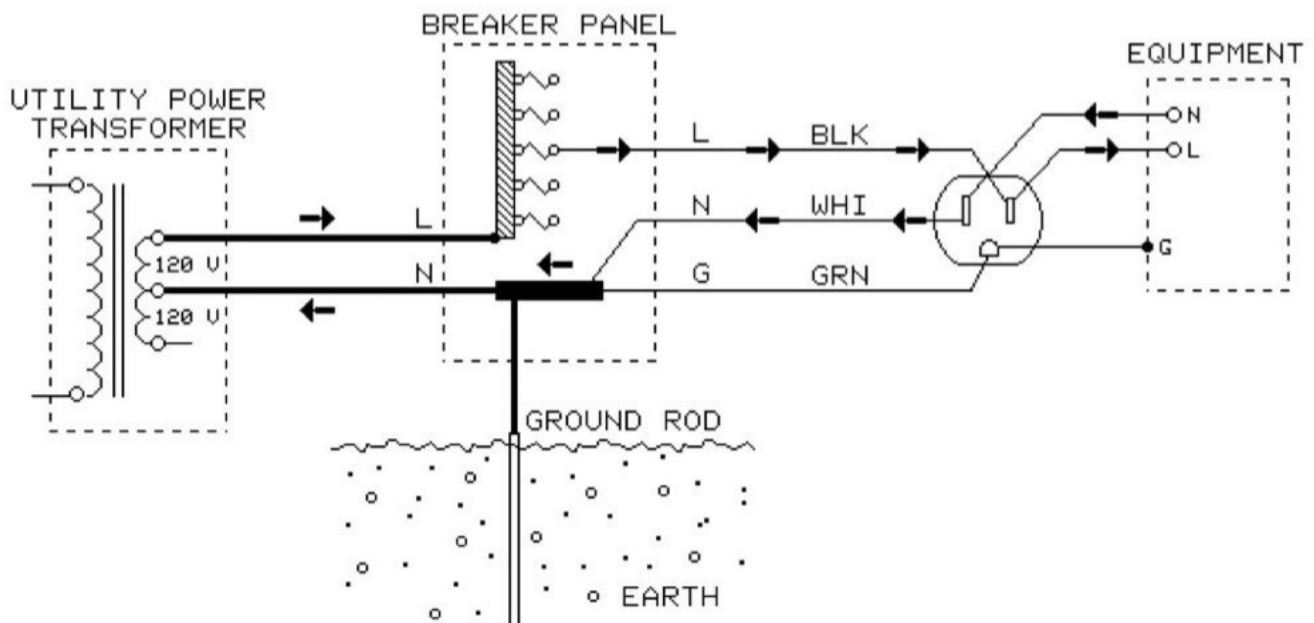

1.1 - PROTECTION FROM DEFECTIVE EQUIPMENT

Any ac line powered device with exposed conductive parts (including signal connectors) can become a shock or electrocution hazard if it develops certain internal defects. For example, *insulation* is used in power transformers, switches, motors and other internal parts to keep the electricity where it belongs. But, for various reasons, the insulation may fail and effectively connect "live" power to exposed metal as shown in the drawing. This kind of defect is called a **fault**.

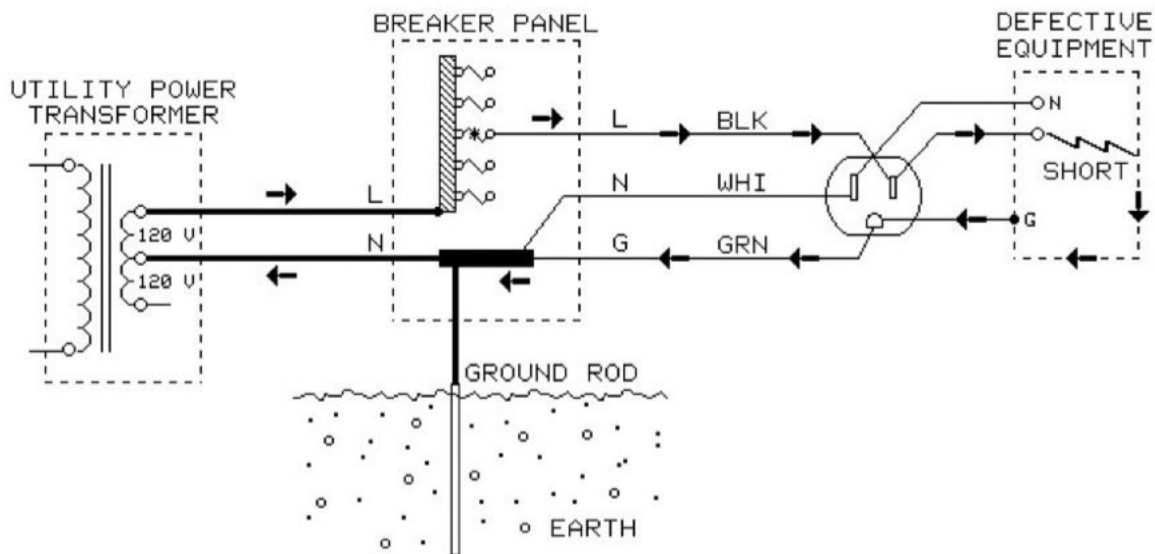

For example, if the motor in a washing machine overheated and caused its insulation to fail, the housing of the machine could assume full line voltage. A person accidentally touching the machine and anything grounded, such as a water faucet, at the same time could be seriously shocked or electrocuted. To prevent this, many devices have a third wire connecting exposed metal to the safety ground pin of their plugs. The outlet safety ground is routed, through either the green wire or metallic conduit, to the **neutral** conductor at the main breaker panel. This low-impedance connection to **neutral** allows high fault current to flow, quickly tripping the circuit breaker and removing power from the circuit. To function properly, the **SAFETY GROUND MUST RETURN TO NEUTRAL**. Note that the earth connection had absolutely nothing to do with this process!

NEVER, EVER use devices such as 3 to 2-prong ac plug adapters, a.k.a. "ground lifters," to solve a noise problem!

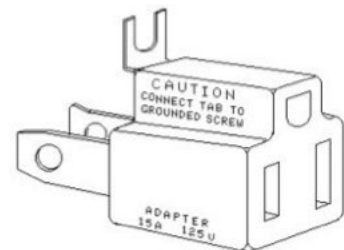

Such an adapter is intended to **provide** a safety ground (read the fine print) in cases where 3-prong plugs must be connected to 2-prong receptacles. If a proper safety ground isn't available, always use a ground-fault circuit interrupter or GFCI. A GFCI works by sensing the difference in current between the line and neutral conductors. This difference represents current in the hot conductor that is **not** returning in the neutral - the assumption is that the missing current is flowing through a person. If the difference reaches about 5 mA, an internal circuit breaker is tripped. The GFCI shown at left is unusual because it has a retractable ground pin that allows it to be used with a 2-prong outlet. [5]

Consider two devices connected by a signal cable, each device having a 3-prong ac plug. One device has a ground "lifter" on its ac plug and the other doesn't. If a fault occurs in the "lifted" device, the **fault** current flows through the **signal** cable to get to the grounded device. It's very likely that the cable will melt and burn! **Defeating safety grounding is both dangerous and illegal - it also makes you legally liable!**

In a typical year, consumer audio and video equipment **electrocutes** 10 people and causes some 2,000 residential **fires** which result in 100 civilian **injuries**, 20 **deaths**, and over \$30 million in property losses. [6] [7]

The resistance of *dry* human skin is high enough to safely allow lightly touching a live 120-volt conductor, but normal skin moisture allows more current to flow as does increased contact area and pressure. It is current that determines severity of electric shock. At 1 mA or less, it's simply an unpleasant tingle. But at about 10 mA, involuntary muscle contractions can result in a "death grip" - or suffocation if the current flows through the chest. Currents of 50 to 100 mA through the chest usually induce ventricular fibrillation that leads to death. **Always have a healthy respect for electricity!**



1.2 - PROTECTION FROM LIGHTNING

An **EARTH** ground is one actually connected to the earth and is necessary for **LIGHTNING** protection. Overhead power lines are frequent targets of lightning. Before modern standards such as the Code existed, power lines effectively directed lightning strikes into buildings, starting fires and killing people. Therefore, virtually all modern electric power is distributed over lines that have one conductor connected to earth ground periodically along its length. These and the earth ground at the service entry panel serve as easy, low-impedance paths to discharge lightning strikes before they can enter the building. Telephone, CATV, and satellite TV cables are also required to "arrest" lightning energy before it enters a building. Another benefit of the safety ground to *earth ground* connection is that, during an equipment fault event, only a few volts will be present on the exposed parts of the faulty device with respect to other earth-grounded objects. Since soil has resistance just like any other conductor, earth ground connections are **not** at zero volts, with respect to each other or any other mystical or "absolute" reference point. Code allows the resistance to earth (measured with special techniques) of a residential ground rod to be as high as 25 Ω . It is far too high to trip the circuit breaker under fault conditions in the dangerous hookup shown on the next page (claimed to be a "quieter" equipment ground). The soil resistance between separate ground rods can also allow thousands of volts to develop between them if lightning strike current should actually flow in one of them. This can seriously damage a computer modem, for example, if it "straddles" a computer (grounded via its power cord to the utility ground rod) and a telephone line protected via a separate ground rod. [3] For this reason, other protective ground connections (telephone, CATV, etc.) should be made to the same rod used for utility power, if at all possible. If multiple ground rods are used, Code requires that they all **must** be bonded to the main utility power grounding electrode. [4]

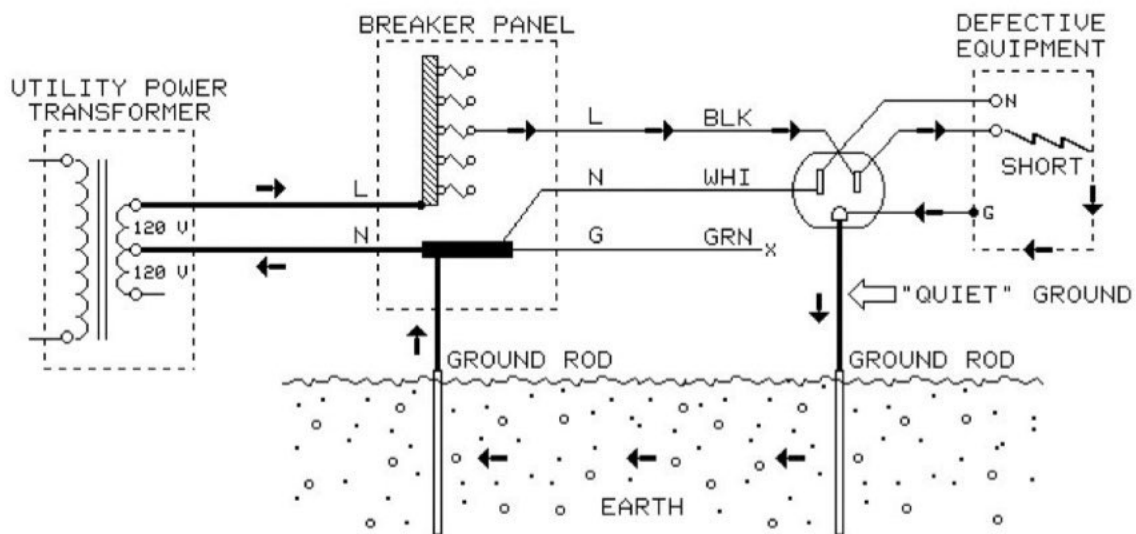

1.3 - THE FACTS OF LIFE ABOUT AC POWER

Most systems consist of at least two devices which operate on utility ac power. Although hum and other problems are often blamed on improper grounding, in most cases there is actually nothing “improper” about the system grounding. A properly installed, fully code-compliant ac power distribution system will develop small, entirely safe voltage differences between the safety grounds of all outlets. In general, the lowest voltage differences (a few millivolts) will exist between physically *close* outlets on the *same* branch circuit and the highest (up to several volts) will exist between physically *distant* outlets on *different* branch circuits. These normally insignificant voltages cause problems only when they exist between vulnerable points in a system — which is more unfortunate than improper.

In all real equipment, there are **parasitic capacitances** between the power line and the equipment ground. They are the unavoidable inter-winding capacitances of its power transformer that are *never* shown in schematic diagrams. Especially if the equipment contains anything digital, internal electro-magnetic interference (a.k.a. EMI) filters will further add to the capacitance. These capacitances allow **leakage current** to flow between power line and chassis/ground inside each piece of equipment.

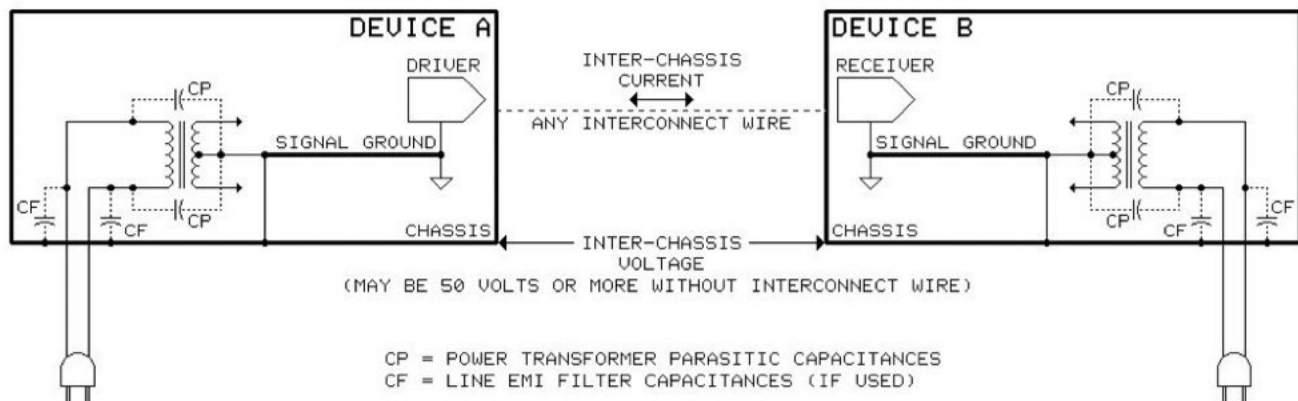

In UL-approved ungrounded (i.e., 2-prong ac power plug) devices, this current is limited to 0.75 mA. Such equipment incorporates a number of protective mechanisms so that it remains

safe in spite of internal component failures, overload, and rough handling. Because this equipment is ungrounded, its chassis (or input/output connections) can assume relatively high voltages with respect to the ground system. Although a voltmeter may indicate well over 50 volts, the current available is small and will cause only a slight tingle if it flows through a person. However, any connection between two such devices or such a device and a grounded one will carry this leakage current. **We must accept this fact as reality.**

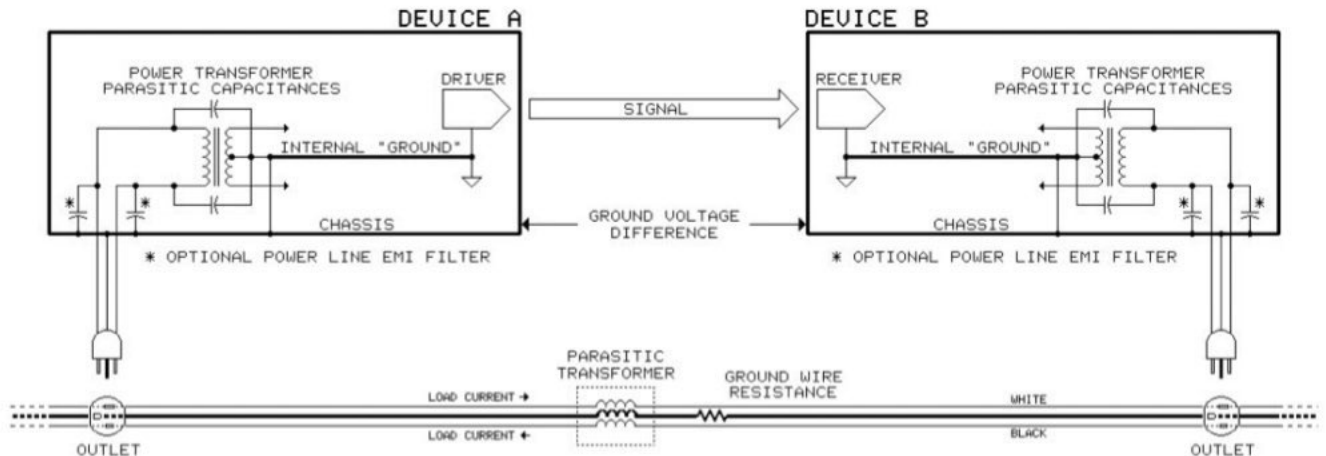

In UL-approved grounded (i.e., 3-prong ac power plug) devices, leakage current is limited to 5 mA. It flows into the safety ground and accumulates in a branch circuit, generating small voltage drops in the resistance of the wiring. However, for grounded equipment, the effects of leakage current are usually insignificant compared to voltage differences between outlet grounds. Substantial voltages are *magnetically induced* in premises safety ground wiring by the imperfect cancellation of magnetic fields that surround the two load-current-carrying conductors. The highest induced voltages generally occur with individual loose wires in steel conduit, which enhances the magnetic efficiency of the parasitic transformer. Considerably lower induced voltages are generally produced by the uniform conductor geometry of Romex® or similar bonded cable. In any case, a small but significant ground voltage difference (1 volt is not unusual) will exist between the chassis or local "ground" of any two pieces of safety-grounded equipment. **We must also accept this fact as reality.**

1.4 - IT'S NOT JUST 60 HZ

Power-line voltage **normally** consists of a broad spectrum of harmonics and noise in addition to the pure 60 Hz sine wave. The noise is created by power supplies in electronic equipment, fluorescent lights, light dimmers, and intermittent or sparking loads such as switches, relays, or brush type motors (blenders, vacuum cleaners, etc.). The drawing at right shows how sudden changes in load current caused by an ordinary phase-control light dimmer generate high-frequency power line noise. At high frequencies, a building's power wiring behaves like a system of mis-terminated transmission lines gone berserk, reflecting high frequency energy back and forth throughout the building's wiring until it is eventually absorbed or radiated.

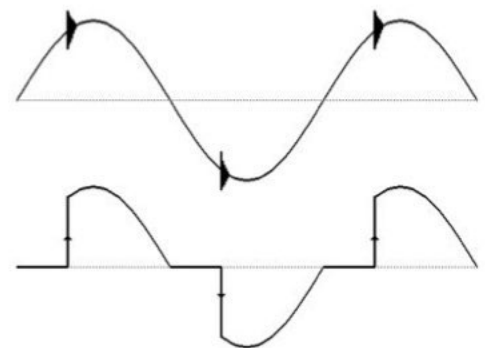

Upper = Line Voltage
Lower = Lamp Current

The graph at right shows the spectrum of leakage (noise) current flow in a 3 nF parasitic capacitance fed by a typical ac outlet. The 60 Hz harmonics, almost entirely odd-order due to “flat-top” distortion of the power line voltage, are what give “buzz” its sonic character. Note how much energy exists above 100 kHz, including AM radio.

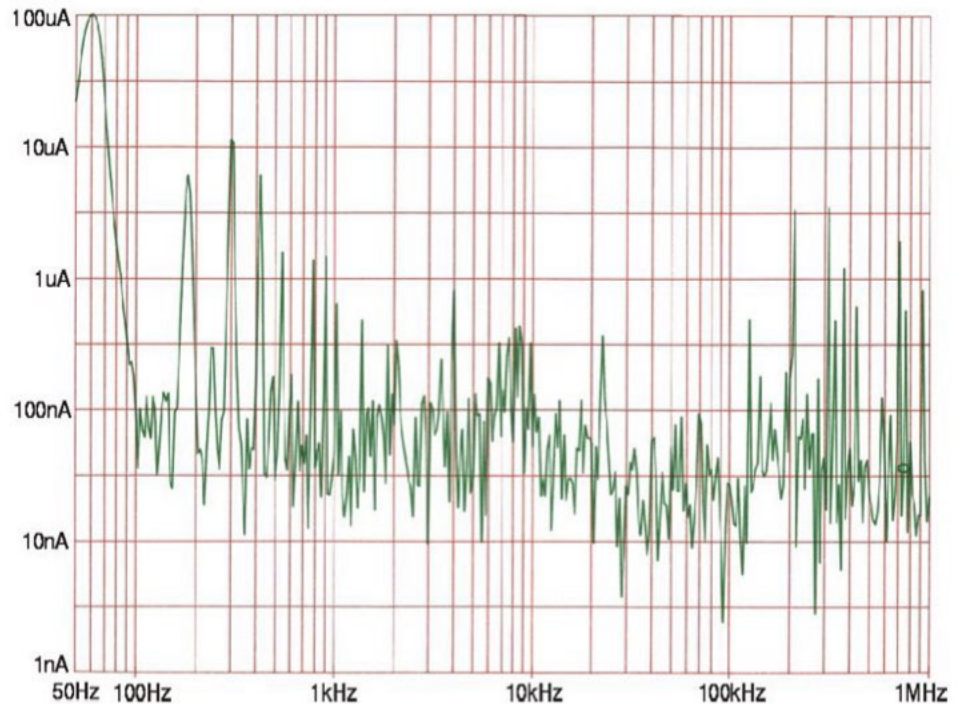

2 - UNBALANCED AUDIO INTERFACES

The price alone of high-end audiophile equipment might imply that designs are state-of-the-art. Manufacturers often tout very impressive measurements of performance. But, because the measurements are made in a laboratory setting, they reveal nothing about the noise problems that are all too common in real-world systems. Sadly, most audiophile and virtually all consumer audio devices still use **unbalanced** interfaces that are inherently *extremely susceptible* to power-line noise. This seems ironic when you consider that the signal-to-noise ratio of available program material has steadily increased over the last 50 years.

2.1 - INTERFACES AND IMPEDANCES

An **interface** is a signal transport sub-system consisting of a line **driver** (one device's output), the **line** or cable itself, and a line **receiver** (another device's input). An interface may be **unbalanced** or **balanced**, depending **only** on the **impedances** (to ground) of the line's two conductors. As shown above, in an **unbalanced** interface, one conductor is grounded (zero-impedance) and the other has some higher impedance.

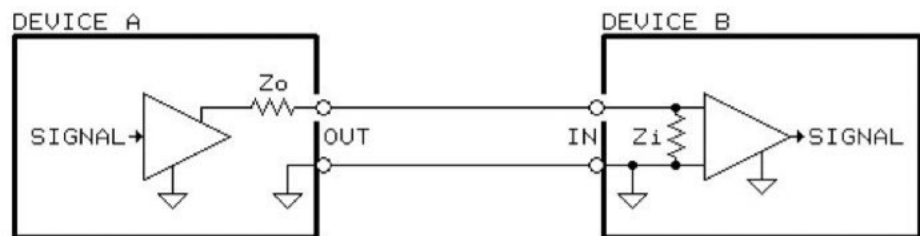

Every **driver** has an internal impedance called its **output impedance**, shown as Z_o . For practical reasons, real equipment outputs do not have zero output impedance. Likewise, every **receiver** has an internal impedance called its **input impedance**, shown as Z_i . For practical reasons, real equipment inputs do not have infinite input impedance.

When an output is connected to an input, the output impedance of the driver and the input impedance of the receiver form a **series circuit**. Since current is the same in all parts of a series circuit but voltage drops are proportional to impedance, it is sometimes called a **voltage divider**. Thus, to transfer maximum signal **voltage**, Z_i should be much larger than Z_o . In typical equipment, Z_o ranges from $100\ \Omega$ to $1\ \text{k}\Omega$ and Z_i ranges from $10\ \text{k}\Omega$ to $100\ \text{k}\Omega$. This transfers 90% to 99.9% of the available signal voltage.

Low output impedance is important! *Output* impedance is often confused with *load* impedance and is frequently missing from vendor spec sheets. Sometimes "20 k Ω minimum load impedance" is the only spec for an output - and not very useful!

2.2 - MATCHING AND TERMINATION

A common misconception is that *audio* outputs and inputs must be **impedance matched**. Circuit theory tells us that when source and load impedances are the same, maximum *power* is transferred. Although useful in some passive signal processing systems, this concept does NOT apply to modern audio signal interfaces. Their goal is to transfer **voltage**, not power! If Z_i is made to match Z_o , half the signal voltage is lost *and* the output drives an unnecessarily heavy load.

However, impedance matching or **termination** is required for video and RF cables because the signals have much shorter wavelengths! As a general rule, cables begin to exhibit "transmission line" effects when their physical length is 10% or more of a **wavelength** at the highest signal frequency. This occurs with video cables over a few feet long and with CATV cables over a few inches long. To avoid reflections of energy from one end of the cable to the other, the driving source and receiving load impedances at each physical end of the cable must match the cable's **characteristic impedance**. Such reflections will cause visible "ghosts" or "rings" in video images. For AUDIO cables, termination is NOT necessary unless cables are over about 4,000 feet long!

2.3 - HOW THE NOISE GETS IN

With *ungrounded* devices, power-line leakage current flows in the grounded signal conductor. [10] Since this conductor has resistance, a small noise voltage is generated over its length. Because the interface is a series circuit, this noise voltage is *directly added* to the signal arriving at the receiver. Because the impedance of the grounded conductor is "common" to both signal and noise current paths, this mechanism is called **common impedance coupling**.

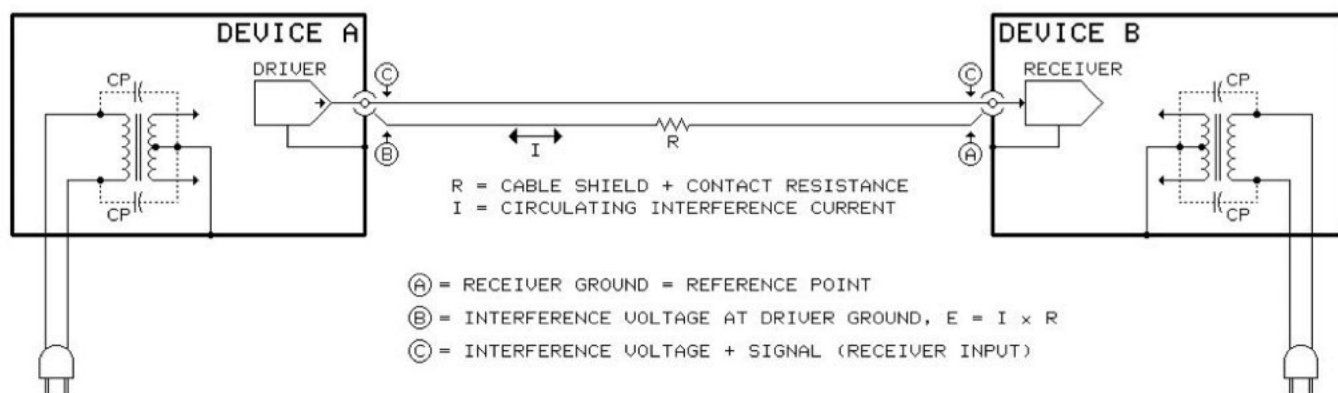

Consider a 25-foot interconnect cable with foil shield and a #26 AWG drain wire. From standard wire tables (or actual measurement) its shield resistance is found to be $1.0\ \Omega$. *The resistance of the inner conductor is insignificant and is not discussed here.* If the leakage current is $316\ \mu\text{A}$, the

noise voltage will be 316 μ V. Since the -10 dBV reference level for consumer audio is 316 mV, the noise will be only $20 \times \log(316 \mu\text{V} \div 316 \text{mV}) = -60$ dB relative to the signal. For most systems, this is a *very poor* signal-to-noise ratio. Replacing the cable with Belden #8241F, for example, would reduce shield resistance to 0.065 Ω and reduce noise by about 24 dB!

Common-impedance coupling can become very severe in an unbalanced interface between two *grounded* devices. Any ground voltage difference developed in the building wiring, which generally ranges from a few millivolts to a volt, is effectively impressed across the ends of the grounded signal conductor, typically the cable shield. Ground voltage differences may be even higher between the power grounding system and some other ground connection, such as a CATV feed. In audio systems, this results in a severe hum problem.

2.4 - FINDING THE PROBLEM INTERFACE

Under fortuitous conditions, systems may be acceptably quiet in spite of poor techniques. But physics will ultimately rule and noises may appear for no **apparent** reason! If we understand how grounding systems and interfaces actually work and how noises couple into signals, finding and fixing problems becomes simple and logical.

Perhaps the most important aspect of troubleshooting is how (or if) you think about the problem. Without a **methodical** approach, chasing noise problems can be both frustrating and time-consuming. For example, don't fall into the trap of thinking something can't be the problem just because you've always done it that way. Remember, things that "can't go wrong" do! Further, problems that go away by themselves also tend to reappear by themselves!!

Don't start by changing things! Because many problems reveal themselves if we just gather enough clues, gather as much information as possible before you change anything.

Ask questions! Troubleshooting guru Bob Pease suggests these basics: Did it ever work right? What symptoms tell you it's not working right? When did it start working badly or stop working? What other symptoms showed up just before, just after, or at the same time? [20]

Be alert to clues from the equipment itself! Operation of the equipment's controls, along with some simple logic, can provide very valuable clues. For example, if the noise is unaffected by the setting of a volume control or selector, logic dictates that it must be entering the signal path after that control. If the noise can be eliminated by turning the volume down or selecting another input, it must be entering the signal path before that control.

Write everything down! Less than perfect memory can waste a lot of time.

Sketch a block diagram of the system! Show all signal interconnecting cables, including digital and RF, and indicate their approximate length. Mark any balanced inputs or outputs. Generally, stereo pairs can be indicated with a single line. Note any equipment that's grounded via its 3-prong power plug. Note any other ground connections such as cable TV or DSS dishes.

Work through the system backwards! As a general rule, and unless clues suggest another starting point, always begin at the inputs to the power amplifiers (for audio systems) or the input to the monitor (for video systems) and sequentially test interfaces backward toward the signal sources. Easily constructed test adapters or "dummies" allow the system to test itself and pinpoint the exact entry point of noise or interference. By temporarily placing the dummies at strategic locations in the interface, precise information about the nature of the problem is also revealed.

The tests can specifically identify:

- Common-impedance coupling in unbalanced cables (vast majority of problems),
- Magnetic or electrostatic pickup by cable of nearby fields, or
- Common-impedance coupling *inside* defective equipment (see 3.3 for details).

The dummies are made from standard connectors wired as shown at right. THEY DO NOT PASS SIGNAL, so make sure they're clearly marked and don't accidentally become permanently installed in a system! **Be very careful not to damage speakers or ears!** The surest way to avoid problems is to turn off the power amplifier(s) before re-configuring cables for each test step.

Unbalanced Interfaces



For Audio RCA

P1 = Switchcraft 3502 Plug

J1 = Switchcraft 3503 Jack

R = 1 k Ω , 5%, 1/4 W Resistor

For Audio 2C Phone

Use Switchcraft 336A and 345A
Adapters with RCA version

Each signal interface is tested using the following four-step procedure:

STEP 1 - Unplug the cable from the input of Box B and plug in only the dummy.

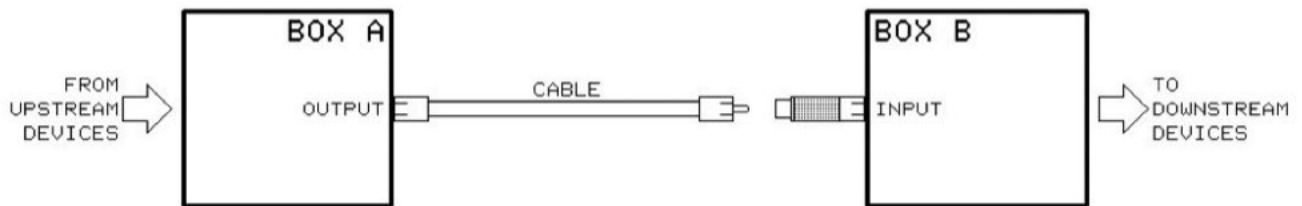

Output quiet? **No** — The problem is either in Box B or further downstream.

Yes — Go to next step.

STEP 2 - Leaving the dummy in place at the input of Box B, plug the cable into the dummy.

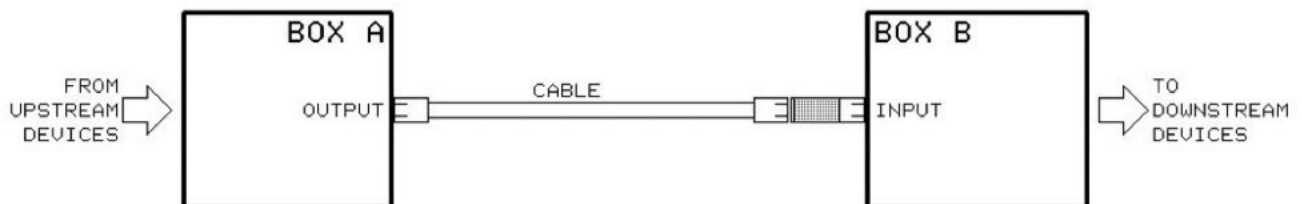

Output quiet? **No** — Box B has an internal "pin 1 problem." The hummer test can confirm this.

Yes — Go to next step.

STEP 3 - Remove the dummy and plug the cable into the input of Box B. Unplug the other end of the cable from Box A and plug it into the dummy. *Be sure the dummy doesn't touch anything conductive.*

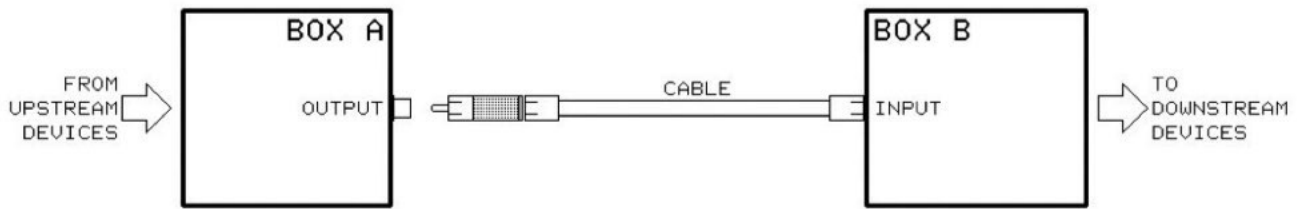

Output quiet? **No** — Noise is being induced in the cable. Re-route it to avoid interfering fields.
Yes — Go to next step.

STEP 4 - Leaving the dummy in place on the cable, plug the dummy into the output of Box A.

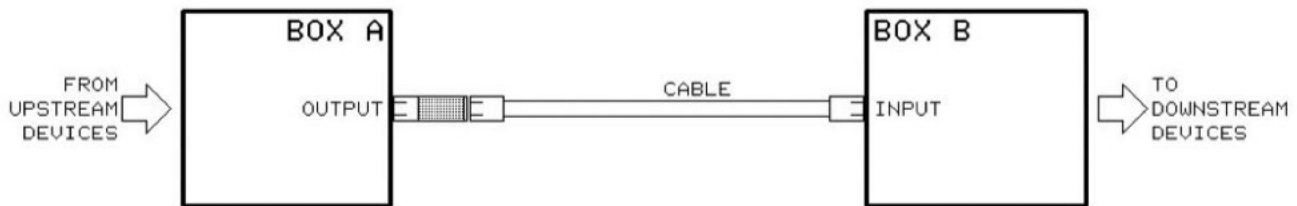

Output quiet? **No** — The problem is common-impedance coupling. Install an isolator in the signal path.
Yes — The noise is coming from the output of Box A. Perform the test sequence at the next upstream interface. Repeat as necessary until problem found.

2.5 - SOLUTIONS

Devices called “ground isolators” solve the fundamental problem with unbalanced interfaces. Broadly defined, they are differential responding devices with high common-mode rejection. An isolator is **NOT A FILTER** that can magically recognize and remove noise when placed *anywhere* in the signal path. In order to solve the problem, **an isolator must be installed in the signal path at the point where the noise coupling actually occurs.**

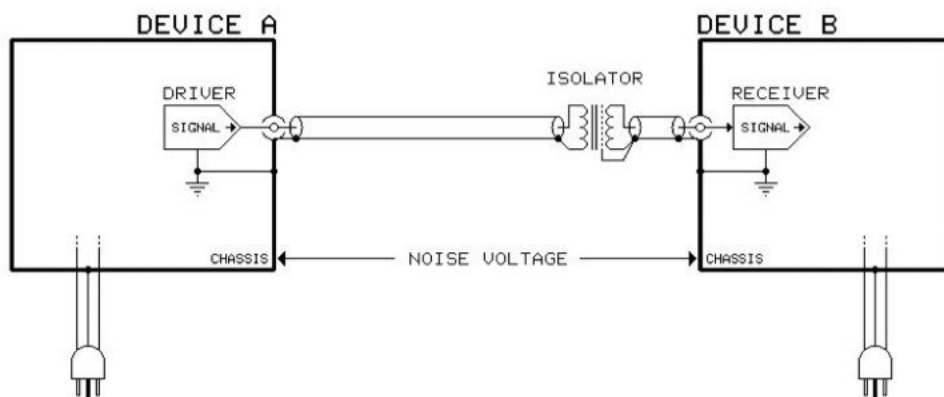

Transformers make excellent ground isolators. They transfer signal voltage from winding to winding *without any electrical connection* between them. This opens the path of the noise current that would otherwise flow between devices.

In theory, since no noise current flows in the cable, noise coupling is *completely* eliminated. But in practice, the reduction in ground noise depends critically on the *type* of transformer used. There are two basic types of audio transformers. The first type, known as **output**, puts primary and secondary windings very close together. The considerable capacitance thus formed allows noise current to couple between windings, especially at higher audio frequencies. Of course, this current

couples noise into the signal as it flows in the cable shield. The second type, known as **input**, places a shield between the windings. Called a **Faraday shield** (*not a magnetic shield*), it effectively eliminates the capacitive coupling between windings, vastly improving noise rejection.

The graph shows noise rejection versus frequency for a typical unbalanced interface. The output impedance of device A is $600\ \Omega$ and the input impedance of device B is $50\ \text{k}\Omega$. By definition, without an isolator, there is 0 dB of rejection in an unbalanced interface as shown by the upper plot. The middle plot shows a typical isolator using an **output** transformer. Although it reduces 60 Hz hum by 70 dB, buzz artifacts around 3 kHz are reduced by only 35 dB. The lower plot shows a typical isolator using an **input** transformer. Its rejection is over 100 dB at 60 Hz and over 65 dB at 3 kHz.

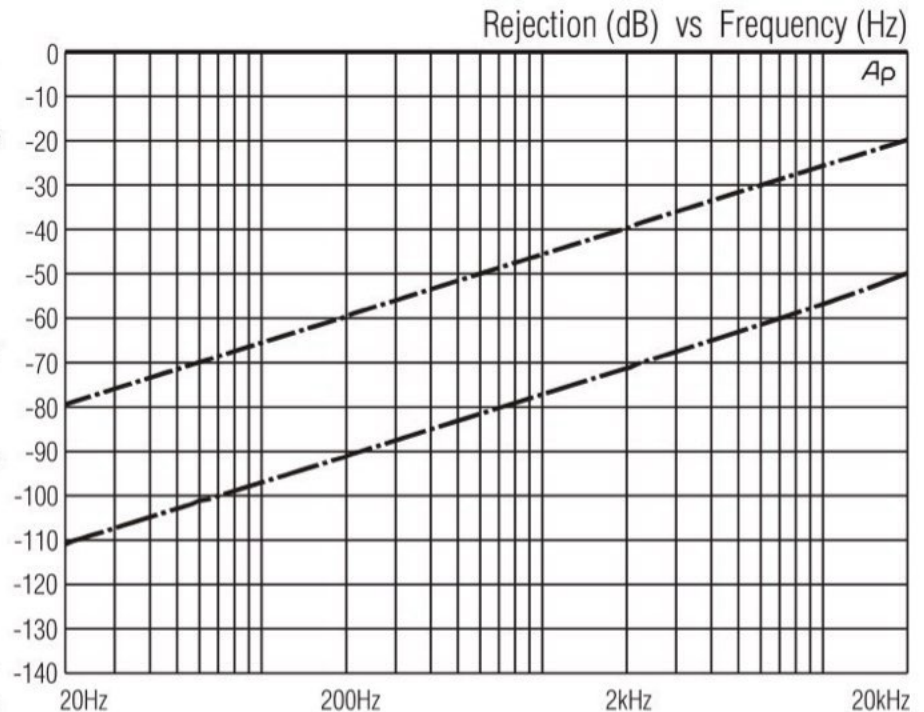

Isolators Using Output-Type Transformers
Ebtech HE-2

There are a remarkable number of “black boxes” on the market intended to solve “ground loop” problems. This includes quite a number of transformer-based boxes. With very rare exception, those boxes contain **output** transformers. An advantage of these boxes is that they can be *installed anywhere* along the length of a cable or can be used at patch-bays.

While boxes containing **input** transformers offer some 30 dB *better noise rejection*, their high-frequency response is degraded by excessive cable capacitance at their outputs. Results are always better, but they must be installed *near the equipment input* using no more than 2 or 3 feet of cable.

Except in extraordinary situations, it is **not** necessary to “balance” a line (using an unbalanced to balanced converter) at the driving end and then “unbalance” it (using a balanced to unbalanced converter) at the receiving end. The noise rejection of such a scheme is no better, and often worse, than that of a single isolator, using an **input** transformer, installed at the receiving end.

Check performance data for isolators carefully. Many have scanty, vague, or non-existent specs — and many use cheap, telephone-grade transformers! These miniature transformers can cause loss of deep bass, bass



Isolator Using Input-Type Transformers
Jensen ISO-MAX CI-2RR

distortion, and poor transient response. Data for high-quality ground isolators, such as the ISO-MAX® series, is complete, unambiguous, and verifiable. Transformer-based isolators have other benefits, too:

- Their inputs are truly **universal**, accepting signals from either *unbalanced* or *balanced* outputs, while maintaining very high noise rejection. Rejection of 100 dB at 60 Hz and over 65 dB at 3 kHz is typical for isolators using Faraday-shielded **input** transformers (*indicated by an “I” in ISO-MAX model numbers*).
- Isolators using **input** transformers also provide **inherent suppression of RF** and ultrasonic interference. The subsequent reduction of “spectral contamination” is often described as a marvelous new sonic clarity. [11]
- They can solve the “pin 1 problem” (common-impedance coupling *inside* poorly designed equipment, see section 3.3).
- They are passive, requiring no power.
- They are inherently robust, reliable, and virtually immune to transient over-voltages.

A wide variety of commercial interface devices are “active” (i.e., powered) devices. Although they incorporate many useful features, they invariably use differential amplifier circuits to “isolate” their unbalanced inputs. As explained later (see section 3.2), the ground noise rejection of ordinary differential amplifiers is extremely sensitive to impedance imbalances in the driving source. With *unbalanced* sources, their entire output impedance becomes “imbalance” and typically ranges from 200 Ω to 1 k Ω or more. Under these conditions, the noise rejection of diff-amps is quite poor.

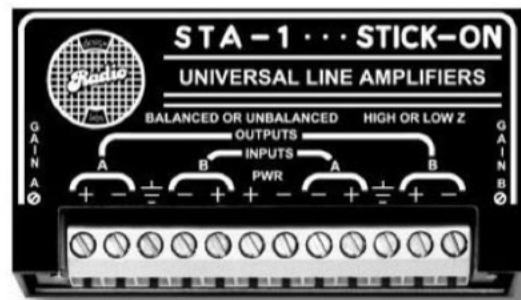

Typical “Active” Interface
Radio Design Labs STA-1

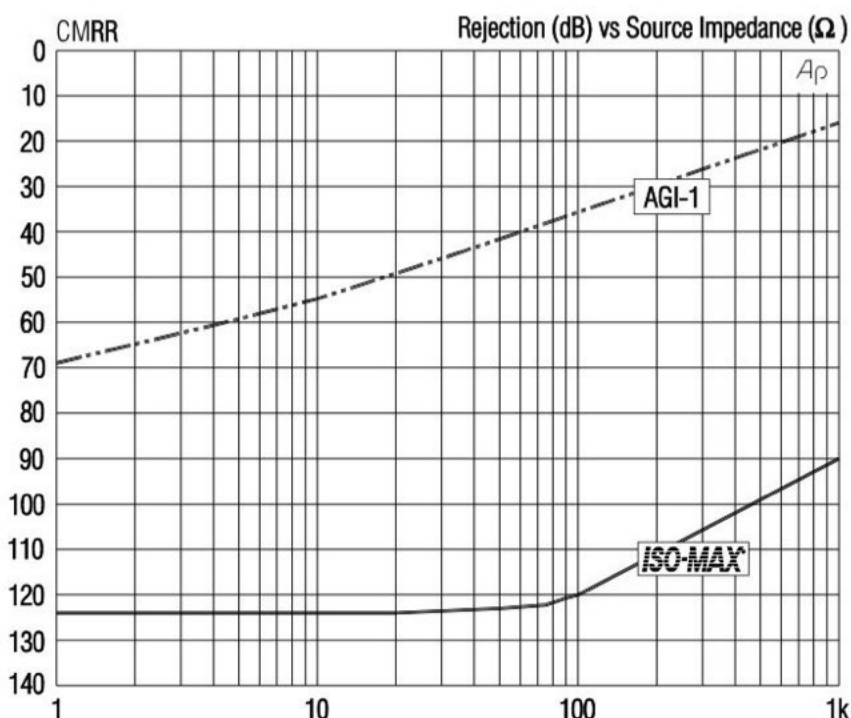

The plots at left compare the 60 Hz hum rejection performance of another typical active interface device, the now discontinued Sonance AGI-1 “audio ground isolator,” to that of an input-transformer based isolator. Over the consumer output impedance range of 200 Ω to 1 k Ω , the *active* isolator achieves only 15 to 30 dB of rejection while the ISO-MAX® CI-2RR isolator improves that by some 80 dB!

2.6 - WHERE TO BREAK THE LOOP

When a system contains two or more pieces of grounded equipment, whether via power-cords or other ground connections, a “ground loop” may be formed.

There is often substantial ground noise voltage between the CATV ground and the ac power safety ground system, causing a relatively large noise current flow in the shield of **ALL** the signal cables that are part of the ground

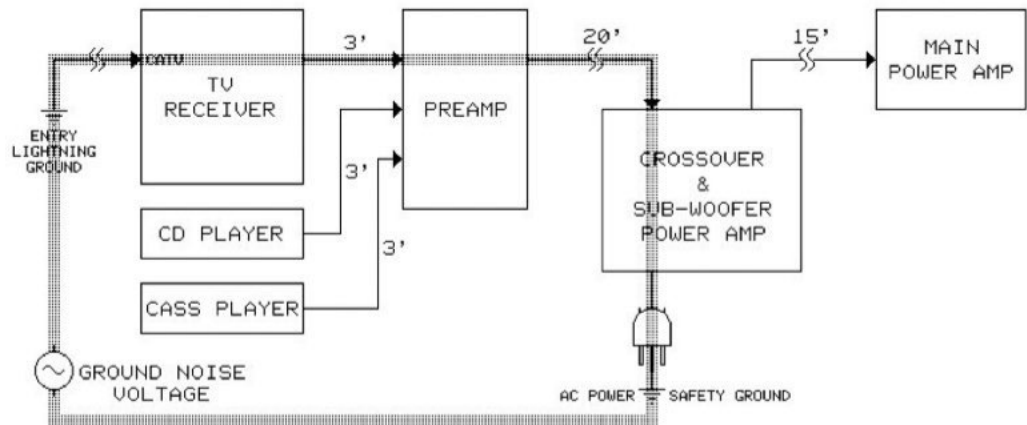

loop between the TV and the sub-woofer. Thus, common-impedance coupling will introduce noise in both *audio* cables in the path, generally in proportion to their lengths. This system would exhibit a loud hum regardless of preamp control settings because of coupling in the 20-foot cable.

Of course, the loop *could* be broken by defeating the sub-woofer safety ground. **DON'T DO IT!** Remember, audio cables that connect equipment together will also carry lethal voltages throughout the system or could start a fire if the sub-woofer develops a power-line fault.

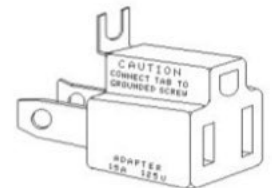

A **safe** way to break the ground loop is to install a ground isolator somewhere in the audio signal path from TV to sub-woofer. Since longer cables are more likely to couple noise, the preferred location in this system would be at the receive end of the longer 20-foot cable, as shown.

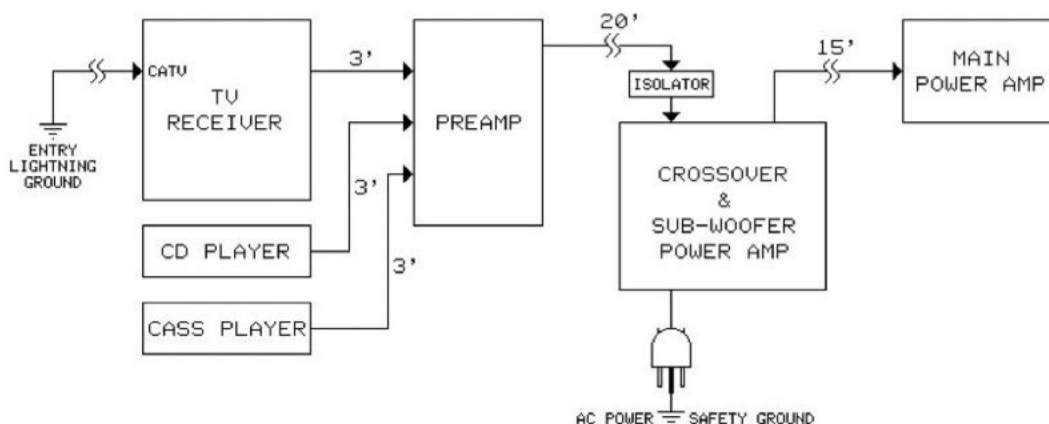

Another **safe** solution is to break the loop by installing a ground isolator in the CATV signal path at the TV as shown. CATV isolators should generally be installed where the cable first connects to the audio or video system, such as at a VCR or TV receiver input.

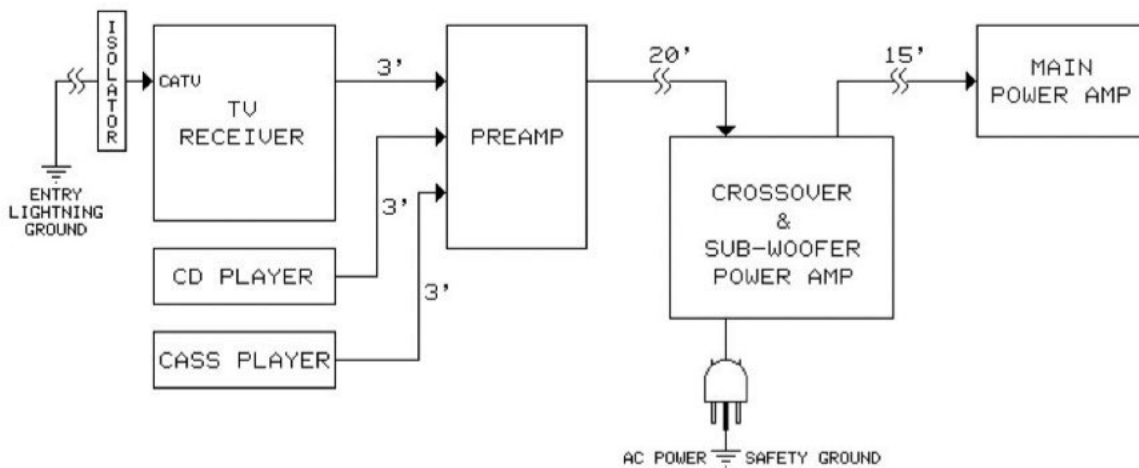

Since most consumer equipment uses 2-prong ac plugs (ungrounded), installing an isolator may leave some devices "floating." This can allow the voltage between the input and output ports of an isolator to approach 120 volts ac.

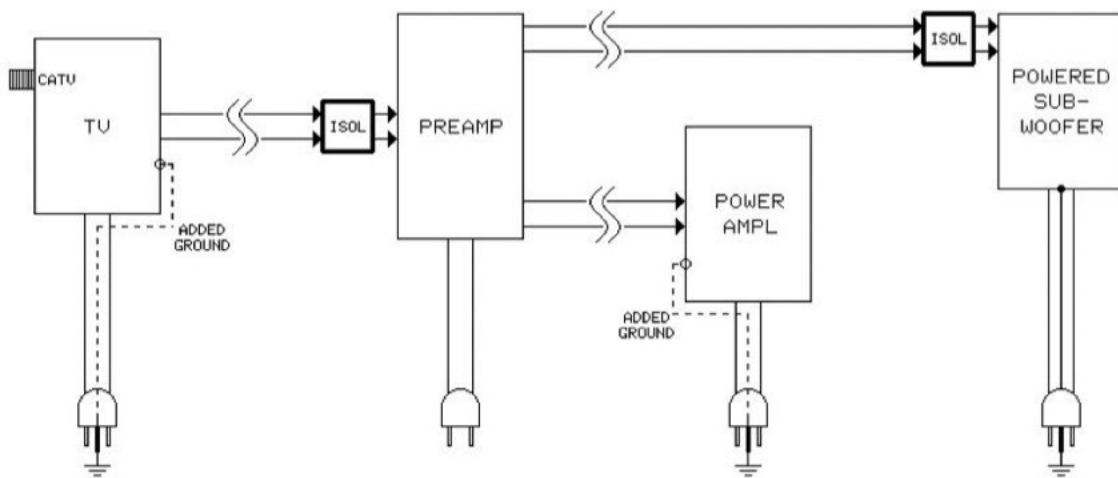

While not dangerous, this situation puts an extreme and unnecessary rejection burden on the isolator! The problem is easily solved by adding separate ground connections to the floating devices. This is most easily done by replacing the equipment's 2-prong plug with a 3-prong type and adding a wire (green preferred) between the safety ground contact of the replacement ac plug and a chassis ground. To find out if a possible chassis connection point (like a screw) is actually grounded, use an ohmmeter to check for continuity to the outer contact of an RCA connector, which itself can serve as the connection point if necessary.

2.7 - CATV AND SATELLITE TV DISHES

High-quality CATV isolators pass high-frequency signals with virtually no loss or degradation but prevent low-frequency current flow, thus preventing power-line ground loops.

- They must **always** be installed downstream of the lightning ground.
- CATV isolators work at CATV, broadcast TV and FM frequencies.



CATV Isolator
ISO-MAX VRD-1FF

The isolator shown also passes cable modem signals.

- Be aware that *signal splitters* connect shields at their outputs, providing possible paths for ground loops *between* destination systems. Separate isolators are generally recommended at each splitter output destination.
- CATV isolators will **NOT** work in the path from DSS dish to receiver. They cannot pass dc power from receiver to the dish.

Satellite dish systems must be grounded in compliance with NEC code sections 250 and 810 to provide protection from lightning. This grounding can create the same kind of ground loops as a CATV connection. An “isolated ground adapter” in series with the ground rod allows the dish to remain **safely ungrounded** under normal operating conditions. The adapter baseplate is connected to the earth ground rod. The dish’s grounding block is then mounted to the ground adapter’s other terminal. The ground wire for the dish assembly itself is also connected to this terminal. Should the voltage across the adapter reach 90 volts, as it would just prior to a nearby or direct lightning strike, an internal gas tube ionizes to its “on” state and is capable of sustaining an 18,000 ampere direct hit of lightning. After the strike, the tube reverts to its “off” state. [26]

If the DSS receiver has a 3-prong (grounding) ac plug, it may be necessary to install a GFCI which safety disconnects its safety ground. In some situations, it may make more sense to use audio and video isolators on the satellite receiver output lines.

2.8 - ISOLATION FOR DIGITAL INTERFACES

The venerable RS-232 data interface is *unbalanced*, making it very susceptible to ground noise via common-impedance coupling — but the noise symptoms are usually called “unexplainable.” The optically isolated device shown can withstand 2,000 volts between its input and output ports. Similar devices are available from several manufacturers for RS-232, RS-422 and other popular interfaces. See www.bb-elec.com or www.telebyteusa.com for more detailed information.



RS-232 Isolator
B&B Electronics

2.9 - CHOOSING CABLES

Strong ac **electric fields** (often inaccurately called *electrostatic fields*) surround any conductor operating at a high ac **voltage** — neon signs and ac power cords, for example. The field strength falls off rapidly with distance. Enclosing signal conductors in a shield can prevent noise coupling due to these *electric fields*.

The space between any two conductors forms a capacitance C_c and any change in the voltage between them requires current flow through the capacitance. Without a **shield**, the current flows in the parallel impedances Z_o and Z_i , adding a noise voltage to the signal. But a grounded shield diverts the noise currents to ground. The

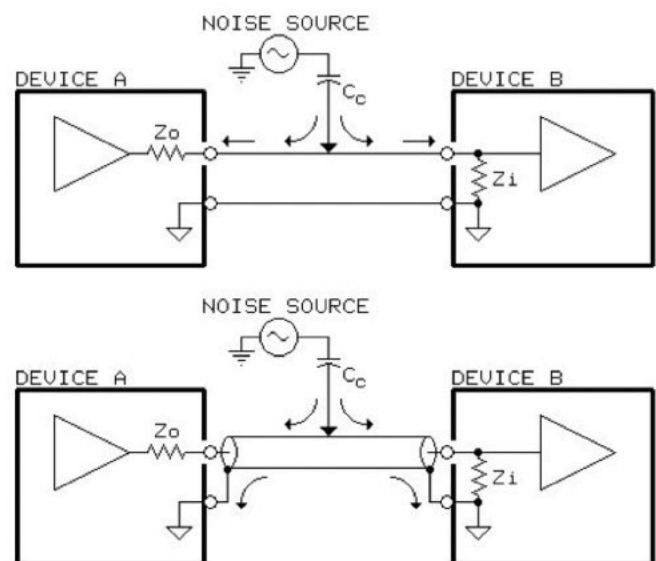

cable's outer shield conductor, if it completely surrounds the inner signal conductor, is said to have 100% coverage. Foil shields are usually 100% while braided shields, because their tiny openings, generally vary from 85% to 95% — entirely adequate in most cases. Electric fields usually cause noise problem only when the driving source has very high impedance, as with some vacuum-tube audio consumer gear. Noise is generally not an airborne contaminant “picked up” by cables with inadequate shielding. To emphasize how generally trivial shielding is in real-world systems, note that one well-known manufacturer has several lines of unbalanced and balanced interconnect cables, ranging in price from \$80 to \$500 per 1-meter pair, which have *no overall shield* — ground and signal wires are simply woven together.

Beware of high capacitance

cables. Some exotic audio cables have very high capacitance and can seriously degrade high frequency response. Cable capacitance and driver output impedance form a low-pass filter. Thus, high output

impedance in combination with long and/or high-capacitance cable can seriously degrade treble response. For example, if the output impedance is 1 k Ω (typical of consumer equipment) and cable capacitance is 50 pF per foot (typical of ordinary cables), 20 kHz response will be down 0.5 dB for 50 feet, 1.5 dB for 100 feet, and 4 dB for 200 feet of cable. Be aware that some “exotic” cables have significantly higher capacitance.

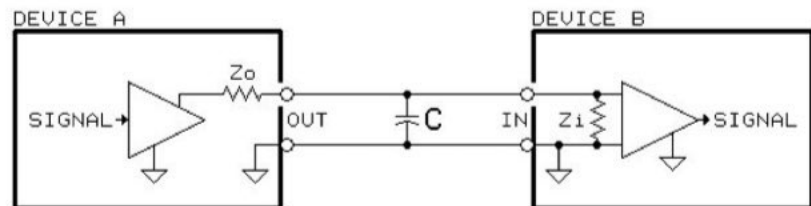

Unbalanced cables are susceptible to ac magnetic fields. Regardless of cable construction, unbalanced interfaces are susceptible to noise induced by nearby ac magnetic field sources. Unlike balanced interfaces, the noise **cannot** be nullified by the receiving input.

Audio cables are NOT transmission lines. Marketing hype for exotic cables often invokes classic transmission line theory and implies that nano-second response is somehow important. Real physics reminds us that audio cables do not begin to exhibit transmission-line effects in the engineering sense until they reach about **4,000 feet** in physical length.

NO OTHER PRODUCT IS AS SHROUDED IN HYPE AND MYSTERY AS THE AUDIO CABLE!

The audio industry, especially the “high-end” segment, abounds with misinformation, myth, and mysticism. Scientific double-blind tests have shown that there is nothing unexplainable about audible differences among cables — when the differences can be demonstrated to truly exist. For example, the physical design of a cable is known to affect its coupling of ultrasonic power line noise. Even very low levels of this noise can cause audible “spectral contamination” in downstream amplifiers. [11] The real solution to this problem is to prevent the coupling in the first place, rather than agonize over which “designer cable” makes the most pleasing improvement.

Expensive and exotic cables, even if double or triple shielded, made of 100% pure unobtainium, and hand-made by virgins, have NO significant effect on hum and buzz problems!

In engineering terms, a high-performance cable for unbalanced audio should have low capacitance and very low shield resistance. A good example of such a cable is Belden #8241F. Its 17 pF per foot capacitance allows driving a 200 foot run from a typical 1 k Ω consumer output while maintaining a -3 dB bandwidth of 50 kHz. Its low 2.6 m Ω per foot shield resistance is equivalent to #14 gauge wire, which can *significantly* reduce common-impedance coupling. It's also quite flexible and available in many colors.

2.10 - A CHECKLIST

Keep cables as short as possible. Longer cables increase the common-impedance coupling. Coiling excess cable length invites magnetic pickup.

Use cables with heavy gauge shields. This is especially important when cables must be long. The *only* property of cable that has any significant effect on audio noise coupling is shield resistance.

Bundle signal cables. All signal cables between any two boxes should be bundled. For example, if the L and R cables of a stereo pair are separated, nearby ac magnetic fields will induce a current in the loop area inside the two shields — coupling hum into both signals. Bundling all ac power cords separately helps to average their magnetic and electrostatic fields, which reduces their net radiation. Of course, keep signal bundles and power bundles as far apart as possible. Remember that cables or bundles that run parallel will couple the most, while those that cross at 90° angles will couple the least.

Maintain good connections. Connectors left undisturbed for long periods can oxidize and develop high (and often distortion-producing non-linear) contact resistance. Hum or other noise that changes when the connector is wiggled indicates a poor contact. Use a good commercial contact fluid and/or gold plated connectors to help prevent such problems.

DO NOT ADD unnecessary grounds. Additional grounding of equipment tends to *increase* system ground noise current rather than reducing it. Of course, NEVER disconnect a safety ground or lightning protection ground to solve a problem.

Use ground isolators at problem interfaces. Isolators are a “silver bullet” solution for common-impedance coupling, which is the major weakness of unbalanced interfaces.

3 - BALANCED AUDIO INTERFACES

An interface may be **unbalanced** or **balanced**, depending *only* on the **impedances** (to ground) of the line's conductors. In *balanced* interfaces, both conductors have **equal** (and non-zero) impedances. A balanced interface requires that driver, line, and receiver **all** maintain balanced impedances to ground. Balanced interfaces are **extremely potent** in preventing all kinds of noise coupling. In fact, it's so powerful that many systems, such as telephone systems, use it instead of shielding as the *main* noise reduction technique!

3.1 - A QUESTION OF BALANCE

The true nature of balanced interfaces is widely misunderstood. For example “*Each conductor is always equal in voltage but opposite in polarity to the other. The circuit that receives this signal in the mixer is called a differential amplifier and this opposing polarity of the conductors is essential for its operation.*” [12] This, like many explanations in print, describes **signal symmetry** (*i.e.*, “*equal in voltage but opposite in polarity*”) but completely overlooks the most important feature of a balanced interface. The notion that signal *symmetry* has anything to do with noise rejection is simply WRONG! Quoting a part of the informative annex of IEC Standard 60268-3: “*Therefore, only the common-mode impedance balance of the driver, line, and receiver play a role in noise or interference rejection. This noise or interference rejection property is independent of the presence of a desired differential signal. Therefore, it can make no difference whether the **desired** signal*

exists entirely on one line, as a greater voltage on one line than the other, or as equal voltages on both of them. Symmetry of the desired signal has advantages, but they concern headroom and crosstalk, not noise or interference rejection." An accurate definition is "A balanced circuit is a two-conductor circuit in which both conductors and all circuits connected to them have the same impedance with respect to ground and to all other conductors. The purpose of balancing is to make the noise pickup equal in both conductors, in which case it will be a common-mode signal which can be made to cancel out in the load." [13] A simplified balanced interface is shown in the schematic.

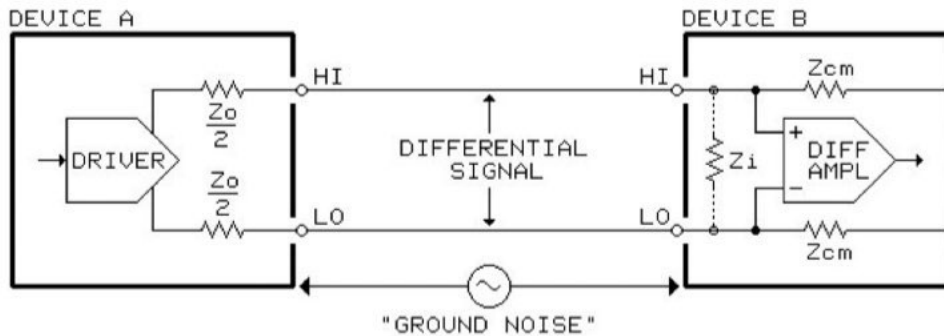

Theoretically, it can reject *any* interference, whether due to ground voltage differences, magnetic fields, or electric fields, as long as it produces **identical** voltages each of the signal lines *and* the resulting peak voltages don't exceed receiver

capability. When both devices are *grounded* to the safety ground system, the ground voltage difference between them becomes the "ground noise" shown. When one or both devices is *ungrounded*, the ground voltage difference can become very large. Traditionally, balanced audio interconnects use shielded cable with each end of the shield connected to respective device ground. This connection serves to minimize the ground voltage difference between the devices. However, if such a connection is absent, other measures may be required to limit the ground voltage difference. The voltage that appears identically on both inputs, since it is *common* to both inputs, is called the **common-mode** voltage.

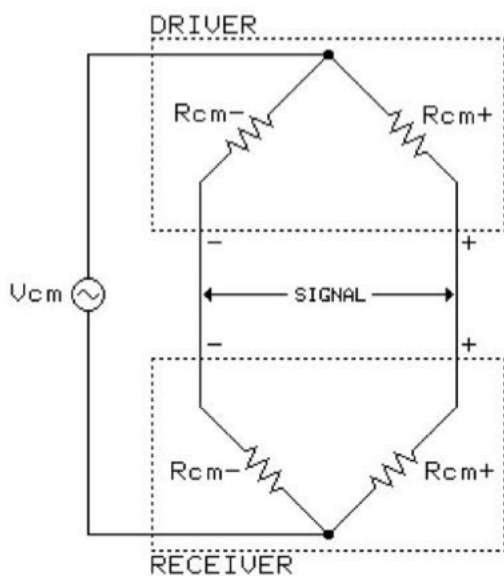

A balanced receiver uses a **differential** device, either a specialized amplifier or a transformer, which inherently responds *only* to the voltage *difference* between its inputs. An ideal receiver would have no response to *common-mode* voltages. But with real devices, the response is not zero. The ratio of the device's *differential* gain to its *common-mode* gain is called its **common-mode rejection ratio**, or **CMRR**. It's usually expressed in dB, where higher numbers mean better rejection. Note that the common-mode (i.e., with respect to ground) output impedances of the driver and input impedances of the receiver effectively form a Wheatstone bridge as shown. If the bridge is not *balanced* or *nulled*, a portion of the ground noise V_{cm} will be **converted** to a differential signal on the line. The nulling of the common-mode voltage is critically dependent on the ratio matching of these pairs of

driver/receiver common-mode impedances. The nulling is relatively unaffected by impedance across the lines — only the common-mode impedances matter!

3.2 - NO TRUTH IN ADVERTISING

The bridge is most sensitive to small fractional impedance changes in one of its arms when all arms have the same impedance. [14] It is least sensitive when upper and lower arms have widely differing impedances. Therefore, we can minimize the *CMRR degradation* in a balanced interface caused by **normal component tolerances** by making common-mode impedances very low at one end of the line and very high at the other. [15] The output impedances of virtually all **real** line drivers are determined by series resistors (and often coupling capacitors) that typically have $\pm 5\%$ tolerances. Because of this, typical drivers can have output impedance imbalances in the vicinity of 10 Ω . The common-mode input impedances of typical balanced input circuits is in the 10 k Ω to 50 k Ω range, making its CMRR *exquisitely sensitive* to normal imbalances in driver output impedance. For example, **the CMRR of the widely used SSM-2141 will degrade some 25 dB with only a 1 Ω imbalance**. Devices such as input transformers or the InGenius® balanced receiver IC, are essentially *unaffected* by imbalances as high as several hundred ohms because their common-mode input impedances are about 50 M Ω — over 1000 times higher than ordinary “active” inputs.

Noise rejection in a real-world balanced interface is often far less than that touted for the input. That’s because the performance of balanced inputs have traditionally been measured in ways that ignore the effects of driver and cable impedances. For example, the old IEC method essentially “tweaked” the driving source impedance until it had **zero** imbalance. Another method, which simply ties the two inputs together and is still used by many engineers, is equally unrealistic. This author is quite pleased to have persuaded the IEC to adopt a new CMRR test that inserts realistic impedance imbalances in the driving source. The new test is included in the third edition of *IEC Standard 60268-3, Sound System Equipment - Part 3: Amplifiers*, August 2000. It’s **very important** to understand that noise rejection in a balanced interface isn’t just a function of the receiver — actual performance in a real system depends on how the driver, cable, and receiver *interact*.

3.3 - PIN 1 PROBLEMS AND THE HUMMER

Dubbed the “pin 1 problem” (pin 1 is shield in XLR connectors) by Neil Muncy, common-impedance coupling has been inadvertently designed into a surprising number of products with balanced interfaces. As Neil says, *“Balancing is thus acquiring a tarnished reputation, which it does **not** deserve. This is indeed a curious situation. Balanced line-level interconnections are supposed to ensure noise-free system performance, but often they do not.”* [16]

The pin 1 problem effectively turns the shield connection into a very low-impedance signal input. Shield current, consisting mainly of power-line noise, is allowed to flow in internal wiring or circuit board traces shared by amplifier circuitry. The tiny voltage drops created are amplified and appear at the device output. When this problem exists in systems, it can interact with other noise coupling mechanisms to make noise problems seem nonsensical and unpredictable. The problem afflicts equipment with unbalanced interfaces, too.

Fortunately, there is a simple test to reveal the pin 1 problem. The “**hummer**” is based on an idea suggested by John Windt. [18] This simple device, whose schematic is shown here, forces an ac

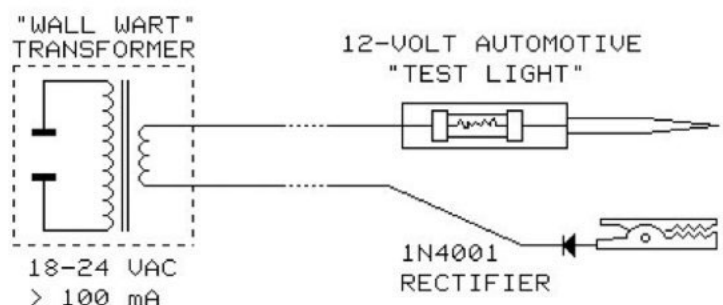

current of about 50 mA to flow through the potentially troublesome shield connections in the device under test. In *properly* designed equipment, this causes no additional noise at the equipment output. *The diode is used to create easily audible harmonics of 60 Hz and the lamp is useful to show that a good connection has been made and current is indeed flowing.*

Testing with the “hummer”:

1. Disconnect all input and output cables, except the output to be monitored, as well as any chassis connections (rack mounting, for example) from the device under test.
2. Power up the device.
3. Meter (and listen, if possible) to the device output. The only noise should be white noise or “hiss.” Try various settings of operator controls to familiarize yourself with the noise characteristics of the device under test *without* the hummer connected.
4. Connect one hummer lead to the device chassis and touch the other lead to the shield contact of each input or output connector. If the device is properly designed, there will be no output hum or change in the noise floor.
5. Test other potentially troublesome paths, such as from an input shield contact to an output shield contact or from the safety ground pin of the power cord to the chassis.

In some equipment, Pin 1 of XLR connectors may not be connected directly to ground — hopefully, this will be at inputs only! In this case, the hummer’s lamp may not glow. This is OK.

3.4 - FINDING THE PROBLEM INTERFACE

Easily constructed test adapters or “dummies” allow the system to test itself and pinpoint the exact entry point of noise or interference. By temporarily placing the dummies at strategic locations in the interface, precise information about the nature of the problem is also revealed. The tests can specifically identify:

- Shield-current-induced coupling in cables,
- Magnetic or electrostatic pickup by cables of nearby fields, or
- Common-impedance coupling *inside* defective equipment.

The dummies are made from standard connectors wired as shown. Remember that **THEY DO NOT PASS SIGNAL**. Each signal interface is tested using the following four-step procedure:

STEP 1 - Unplug the cable from the input of Box B and plug in only the dummy.

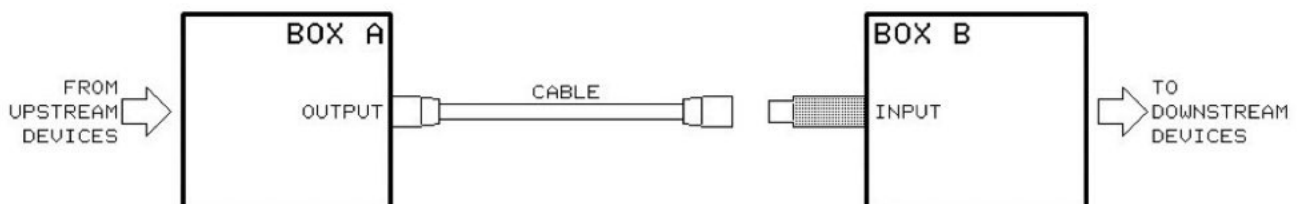

Output quiet? **No** — The problem is either in Box B or further downstream.

Balanced Interfaces

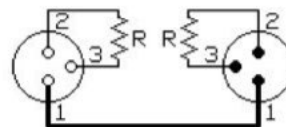

For Balanced Audio XLR

P1/J1 = Switchcraft S3FM Adapter
with QG3F and QG3M Inserts
R = 604 Ω , 1%, 1/4 W Resistor

For Balanced Audio 3C Phone

Use Switchcraft 383A and 387A
Adapters with XLR version

Yes — Go to next step.

STEP 2 - Leaving the dummy in place at the input of Box B, plug the cable into the dummy.

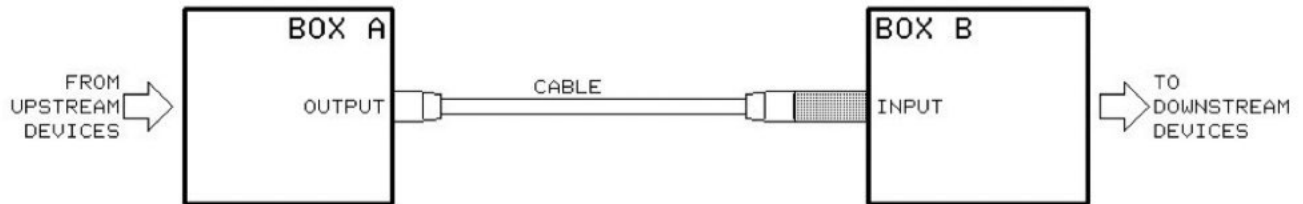

Output quiet? **No** — Box B has an internal “pin 1 problem.” The hummer test can confirm this.
Yes — Go to next step.

STEP 3 - Remove the dummy and plug the cable into the input of Box B. Unplug the other end of the cable from Box A and plug it into the dummy. *Be sure the dummy doesn't touch anything conductive.*

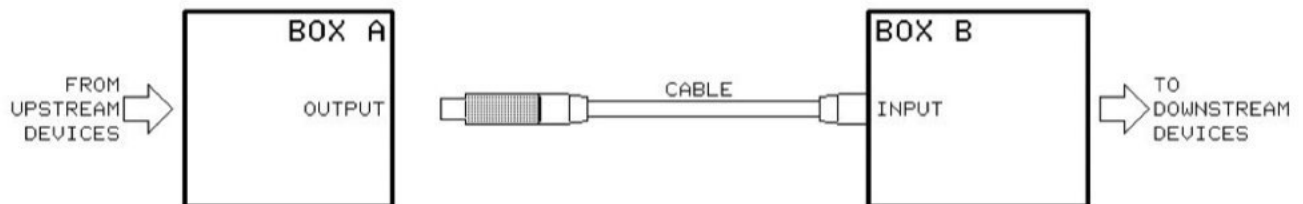

Output quiet? **No** — Noise is being induced in the cable. Re-route it to avoid interfering fields.
Yes — Go to next step.

STEP 4 - Leaving the dummy in place on the cable, plug the dummy into the output of Box A.

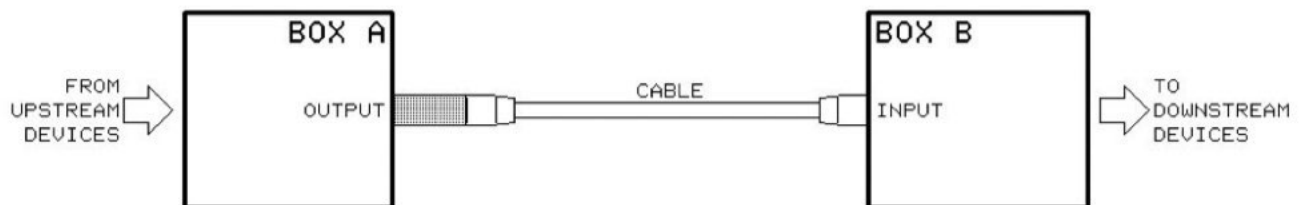

Output quiet? **No** — The problem is shield-current-induced noise or SCIN. Replace the cable with a different type or take steps to reduce current flow in the shield.
Yes — The noise is coming from the output of Box A. Perform the test sequence at the next upstream interface.

3.5 - SOLUTIONS



Isolator for Balanced Interfaces
 Jensen ISO-MAX PI-2XX

The most common problems with balanced interfaces are due to poor CMRR in the equipment input and “pin 1 problems.” The isolator shown here uses *input* transformers to vastly improve CMRR and RF interference rejection. As explained in the previous section, CMRR improvement will depend on what type of transformer is used in the isolator.

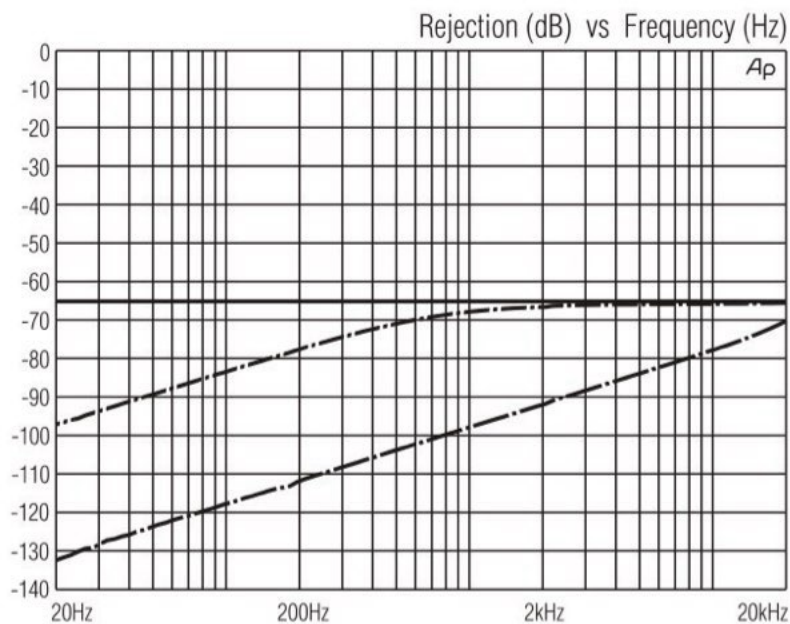

The graph shows CMRR versus frequency for a *balanced* interface tested with the IEC 60268-3 method. The driver is a typical 600 Ω balanced output, except that its common-mode impedances were **precision matched** to within $\pm 0.1\%$ (i.e., virtually zero imbalance). The receiver is a typical “active” (a *three op-amp “instrumentation” circuit*) having an input impedance of 40 k Ω (*common-mode impedances = 20 k Ω*) having **90 dB** CMRR when directly connected to the driver. These are the laboratory conditions under which most **advertised** CMRR figures are obtained!

Recognizing that real-world outputs are very rarely so precisely matched, the new IEC test intentionally imbalances the lines by $\pm 10 \Omega$. For this typical input, with no isolator, the CMRR drops from its advertised or “rated” 90 dB down to 65 dB as shown in the upper plot. The middle plot shows the effect of using an ordinary *output* transformer isolator. While 60 Hz hum is reduced by some 20 dB, the reduction is near zero at 3 kHz. However, a high-performance isolator using an *input* transformer reduces 60 Hz hum by almost 60 dB and reduces 3 kHz (buzz artifacts) by over 20 dB.

As mentioned earlier, **beware of products that are not well-specified**. They can sometimes solve noise problems, but at the expense of sound quality. The isolator shown above also solves pin 1 problems via switches (on its underside) that reconfigure shield connections. As in unbalanced applications, *input* transformer-based isolators have other benefits, too:

- Their inputs are truly **universal**, accepting signals from either *balanced or unbalanced* outputs, while maintaining very high noise rejection. Improvement in CMRR of 40 to 60 dB is typical for isolators using Faraday-shielded **input** transformers (*indicated by an “I” in ISO-MAX model numbers*).
- Isolators using **input** transformers also provide **inherent suppression of RF** and ultrasonic interference. The subsequent reduction of “spectral contamination” is often described as a marvelous new sonic clarity. [11]
- They can solve “pin 1 problem” (common-impedance coupling *inside* poorly designed equipment).
- They are passive, requiring no power.
- They are inherently robust, reliable, and virtually immune to transient over-voltages.

3.6 - ABOUT CABLES AND SHIELD CONNECTIONS

As with unbalanced cables, electric fields can capacitively couple noise into signal conductors. In a balanced interface, equal voltages would theoretically be induced on the two balanced lines.

Since that makes it a common-mode voltage, it is theoretically rejected by the receiver. In practice, the rejection is limited by the matching of both the capacitive coupling and the line impedances. The matching of capacitive coupling can be improved by *twisting* the balanced pair, averaging their physical positions (and capacitances) relative to the field source. However, a grounded **shield** solves the entire problem by simply diverting the noise currents to ground. Here again, braided shields with 85% to 95% coverage are usually adequate.

Shield ground connections can affect CMRR. Cable capacitances between each signal conductor and shield are mismatched by 4% to 6% in typical cable. If the shield is grounded at the receiver end, these capacitances and driver common-mode output impedances, themselves often mismatched by 5% or more, form a pair of low-pass filters for common-mode noise. The mis-tracking of these filters *converts* a portion of common-mode *noise* to differential **signal**. If the shield is simply connected *only* at the driver, this conversion mechanism is completely eliminated because all filter elements are at the same (driver ground) potential! [22]

Signal voltage swings on the inner conductors cause current flow to the shield through the cable capacitances. If signals were perfectly symmetrical (equal and opposite voltage swings) and capacitances were perfectly matched, the two capacitively-coupled *signal* currents into the shield would cancel. However, imperfect symmetry and/or mis-matched capacitances will cause signal current in the shield. This current should be returned directly to the driver from which it came. If the shield is grounded at the *receiver*, all or part of this current will return via an *undefined* path which can induce crosstalk, distortion, or oscillation as it flows through sensitive circuitry. [22] Therefore, for shielded balanced audio cables, **the shield should ALWAYS be grounded at the driver** — whether or not the receiving end is grounded.

However, this conflicts with “mesh” grounding methods preferred at RF frequencies. To guard against RF interference, where typical system cables become a fraction of a wavelength, additional grounding is desirable. Therefore, the most widespread industry practice is to ground the shield at both ends, which compromises CMRR to some degree. But a high-frequency treatment can be superposed on the low-frequency treatment to get both highest possible CMRR and improved RF immunity. This approach, called **hybrid** grounding, couples the receive end of the shield to ground through a capacitor. The capacitor is effectively a short circuit at RF frequencies but an open circuit at audio frequencies. [23] [24] The merits of this scheme have been the subject of several years of debate in an AES Standards Committee working group.

Strong ac **magnetic fields** surround any conductor operating at a high ac **current** — building wiring, power transformers, motors, and CRT displays, for example. The field strength generally falls off rapidly with distance from the source. Physics tells us that any conductor exposed to a time-varying (ac) magnetic field will have a voltage induced in it. In a perfect balanced interface,

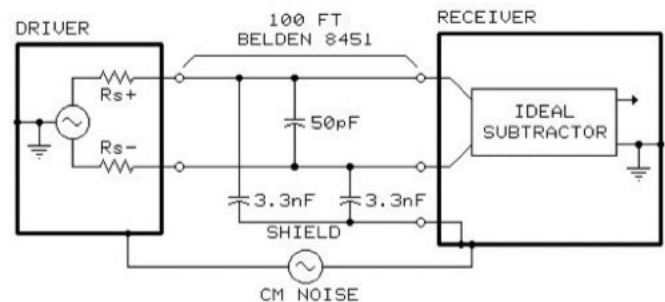

NEVER Ground Shield **ONLY** at Receiver

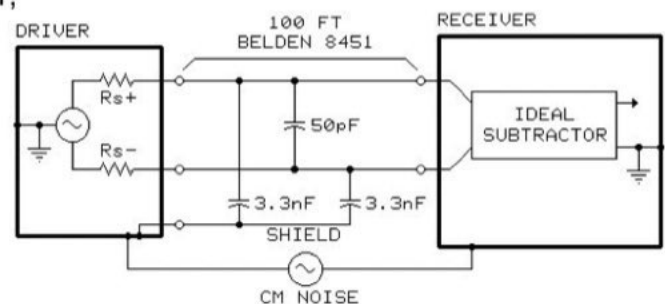

ALWAYS Ground Shield at Driver

equal voltages would be induced in the signal pair, making it a common-mode voltage which would be completely rejected by the receiver. In practice, the rejection is limited by the degree of matching in both the magnetic coupling and the line impedances. The matching of magnetic coupling can be improved by *twisting* the balanced pair, averaging their physical distance to the field source. **Be sure all balanced line pairs are twisted.** Twisting makes shielded or unshielded balanced pair lines nearly immune to *magnetic* fields and makes unshielded balanced lines nearly immune to *electric* fields. This is especially important in low level microphone circuits. Remember that wiring at terminal or punch-down blocks and inside XLR connectors is vulnerable because the twisting is opened up, effectively creating magnetic pickup loops. In magnetically hostile environments, consider “star-quad” microphone cable — it improves immunity to magnetic fields by about 40 dB compared to standard shielded twisted pair cable.

Effective **magnetic shielding**, especially at power frequencies, is very difficult to achieve. Only magnetic materials such as steel conduit can provide significant shielding — it is NOT provided by ordinary shielded cables. Current flow in the cable shield creates a magnetic field very close to the twisted pair. In an ideal cable with perfect symmetry in its physical construction, equal voltages would be induced in the pair and the common-mode voltage would be rejected by the receiver. However, imperfections in real cables result in *unequal* induced voltages that add noise to the differential signal. This effect was noted in 1994 by Neil Muncy who gave it the acronym SCIN for **shield-current-induced-noise**. Generally, the best cables have braided or counter-wrapped spiral shielding and the worst have foil shields and drain wires. [16] [17]

3.7 - UNBALANCED TO BALANCED INTERFACES

Signal operating and reference levels are different in consumer (unbalanced) and professional (balanced) equipment. The consumer reference is -10 dBV or 316 mV rms while the professional reference is +4 dBu or 1.228 V rms. Therefore, a voltage gain of 3.9 or about 12 dB is required.

A fair question might be “Why not use a step-up transformer for this gain?” Several commercial products do, but I do NOT recommend them. Let me explain: Assume the transformer has a turns (voltage) ratio of 1:4 for a theoretical voltage gain of 12 dB. This *unavoidably* makes its impedance ratio 1:16. Therefore, any load impedance at the pro (balanced) side will be reflected to the consumer (unbalanced) side as 1/16 of that. Since typical balanced inputs have impedances ranging from 10 to 40 k Ω , they’ll be seen by the driving consumer output as 625 Ω to 2.5 k Ω . Recall that consumer outputs are typically rated to drive a “10 k Ω minimum load.” That’s because their internal (or “output”) impedance (usually unspecified) is typically 1 k Ω or more. Therefore, the **actual gain is not 12 dB**, but only 3 to 8 dB. In addition, the consumer output will experience a serious **headroom loss**, up to 8 dB, causing premature clipping. Since most consumer outputs use coupling capacitors designed for a “10 k Ω minimum load,” the severe loading will usually result in **poor bass response**, too. Usually, specs relating to these issues are *conspicuously absent* from manufacturers’ data sheets!!



Level-Shifter Using Transformers for Gain
EbTech LLS-2

Gain is usually not a real issue in most systems because pro equipment inputs generally have additional gain “reach.” If we eliminate the gain requirement, we have more options for unbalanced to balanced interfaces. In most cases, **noise rejection** is by far a more important issue.

The widely-used simple hookup shown below, using **shielded single-conductor** cable and an RCA to XLR **adapter**, results in **0 dB** of ground noise rejection — wasting all the potential noise rejection of the balanced input!

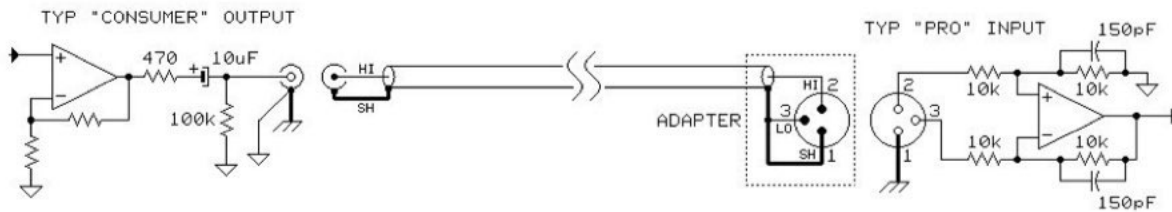

WRONG Connection Uses RCA to XLR Adapter - **Noise Rejection = 0 dB**

The alternate hookup, using **shielded twisted-pair** cable, takes advantage of the noise rejection available from the balanced input. Because ground noise now flows in the shield conductor rather than one of the signal conductors, noise rejection is improved by about 30 dB when the input is a typical "active" differential-amplifier type. If the equipment's balanced input used an input transformer or the InGenius® IC, rejection would be improved by about 80 dB. [27]

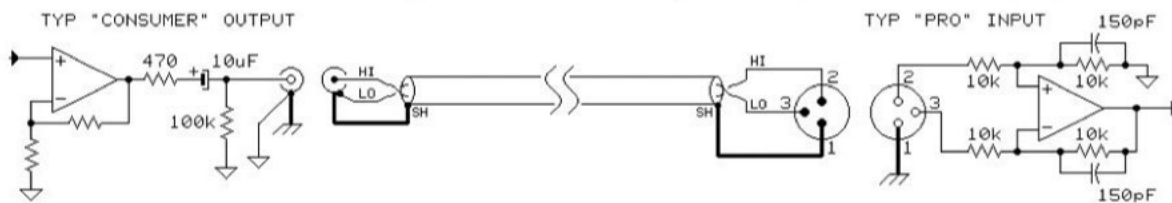

CORRECT Connection is Much Better - **Noise Rejection = 20 dB to 30 dB**

The graph shows noise rejection for various *unbalanced to balanced* interfaces. The top plot at 0 dB represents the simple adapter and 2-conductor cable connection. The plot at -30 dB shows the improvement due to the 3-conductor alternate hookup. The next plot shows the effect of an isolator using an ordinary *output* transformer. It improves 60 Hz hum by a bit over 20 dB, but has little effect on buzz artifacts over about 1 kHz. A high-quality isolator using an *input* transformer increases rejection to almost 100 dB at 60 Hz and about 65 dB at 3 kHz. For the best possible noise rejection, don't use a 2-conductor cable from the unbalanced output to the isolator input. Instead, use a balanced (XLR connector) input and the 3-conductor cable wired as in the alternate hookup. These tests were done using a 600 Ω unbalanced output and the same 40 kΩ balanced input described in section 3.5.

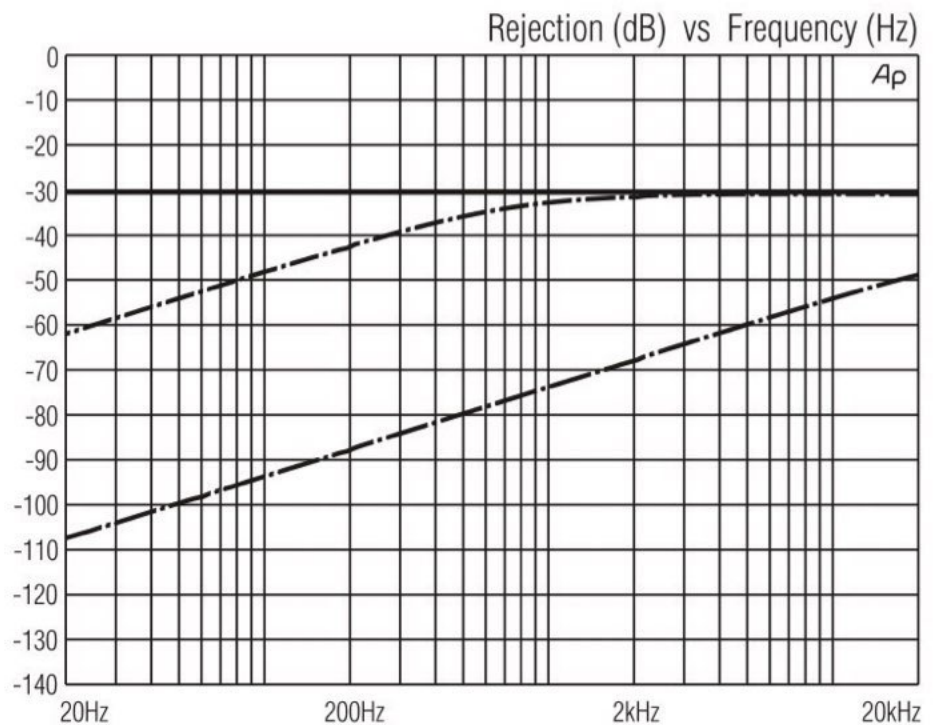

3.8 - BALANCED TO UNBALANCED INTERFACES

Operating **level differences** are a legitimate concern in these interfaces. Because consumer inputs rarely include a passive attenuator, they are easily overloaded by pro signal levels. Again, since the professional reference is +4 dBu or 1.228 V rms and the consumer reference is -10 dBV or 316 mV rms, a loss of about 12 dB is required. Obviously, the output of a professional device could be turned down 12 dB, but then its level meters would be useless and noise performance would be degraded. Rejection of ground noise is also desirable.

The graph shows noise rejection for various *balanced to unbalanced* interfaces. The upper plot at 0 dB represents a direct connection, such as with an adapter or adapter cable. **Direct connections invite problems** because of the wide variety of balanced output circuits in equipment, each having its own limitations. Some, such as the one in the schematic, can be damaged if one of its output terminals is grounded. Outputs stages using either transformers or widely-used "servo-balanced" outputs, must have one terminal grounded in order to produce

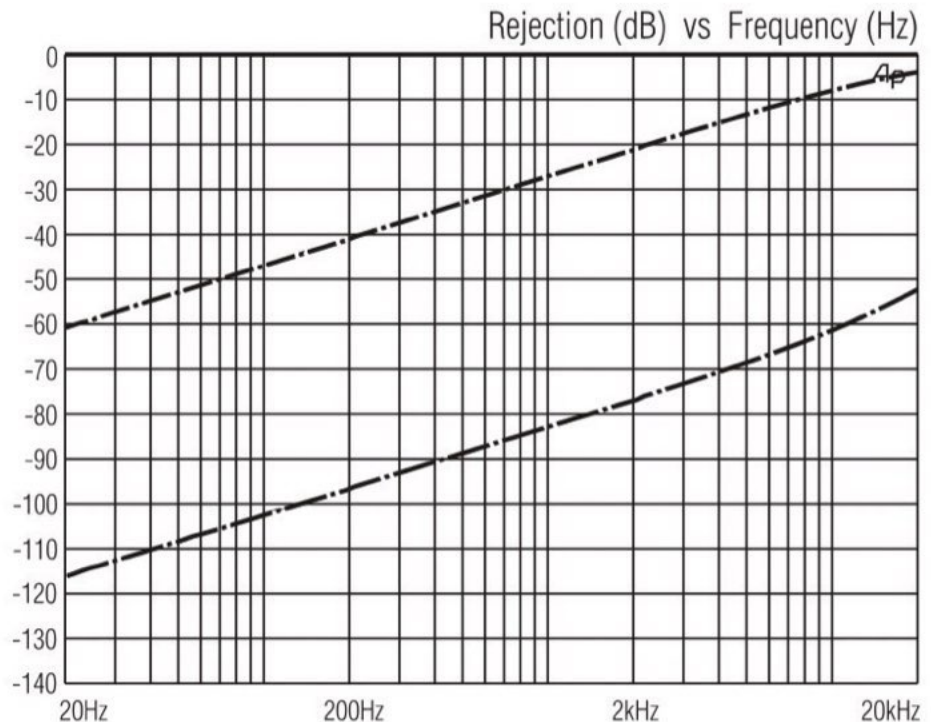

a proper output signal at the other. But the "servo-balanced" output can oscillate or become unstable if the ground connection is made at the far (receive) end of a cable. [28] This dilemma can be solved by using a transformer. The middle plot shows that an *output* transformer reduces 60 Hz hum by about 50 dB and buzz artifacts around 3 kHz by less than 20 dB. A high-quality *input* transformer, such as the one shown below, increases rejection to over 105 dB at 60 Hz and to nearly 75 dB at 3 kHz.

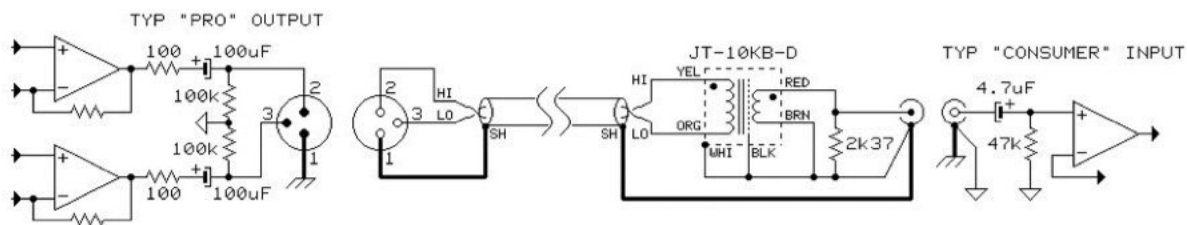

A transformer-based isolator is the **only** "universal" interface that will perform well with **any** known output stage. Conveniently, a transformer with a 4:1 turns ratio also attenuates the signal by the required 12 dB.



Pro to Consumer Isolator
Jensen ISO-MAX PC-2XR

4 - VIDEO INTERFACES

4.1 - THE "HUM BAR"

The Academic Press Dictionary of Science and Technology defines a hum bar as "a dark, horizontal bar in a television picture caused by hum interference in the video signal." For standard NTSC video displays, a disturbance which slowly creeps upward is its signature. The movement is caused by the slight frequency difference between the NTSC video field rate, 59.94 Hz, and the 60 Hz of the power line. The 0.06 Hz frequency difference means it takes about 16 seconds to move from bottom to the top of the screen. As explained earlier, ground voltage differences are often generated by the parasitic transformer in building wiring and are a function of branch circuit load currents. Since many, if not most, loads draw their power-line current as pulses at each peak of the ac cycle (i.e., at 120 Hz), a **pair** of disturbances is most commonly seen.

The shield of coaxial video cable is the return path for the video signal current but, as shown in the drawing, it **also** becomes a path for power-line ground current. The magnitude of the current in this loop depends on the

system ground voltage difference and the total resistance in the loop, in accordance with Ohm's Law. This also means that a voltage drop, proportional to the resistance of the shield, will appear across the length of the cable. Because driver (device A) and receiver (device B) impedances are equal, half of this voltage is added to the signal as seen by the receiver. As in all unbalanced interfaces, the shield impedance (resistance) is common to both the signal and the ground current paths, creating this mechanism called **common-impedance coupling**.

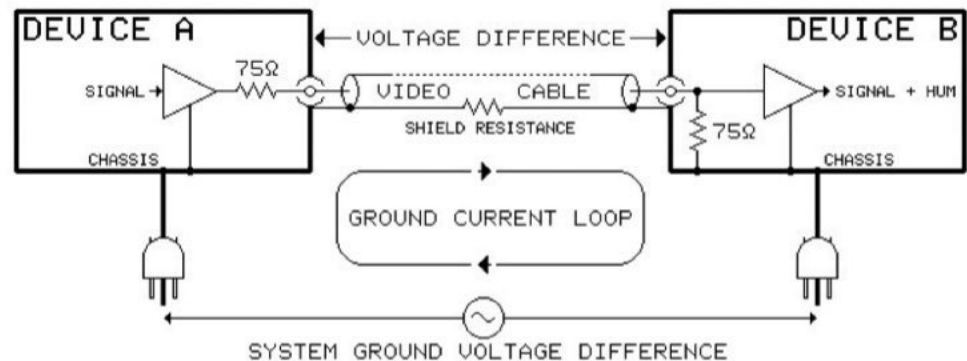

A standard video signal has a total magnitude of 1 V peak-to-peak and about 700 mV of it corresponds to the active black to white range in the displayed image. Although some video displays process video with "pedestal clamping" circuits that make them more tolerant of low-frequency disturbances such as hum bars, interference of less than 7 mV peak-to-peak is discernable in many systems under worst-case conditions. Therefore, as little as 14 mV peak-to-peak of voltage difference from end to end on a cable can create a visible problem. Normal leakage currents from equipment with 2-prong plugs rarely causes a hum bar problem. Generally problems occur only with the higher current flow between two grounded pieces of equipment.

4.2 - FINDING THE PROBLEM INTERFACE [21]

This is a simple variation of the *audio* troubleshooting procedures. Because many, if not most, monitors will revert to a blue screen in the absence of a video signal, this test uses a portable video source to keep the display active. If you do much video work, you may already own something similar to the B&K Precision model 1257 NTSC pattern generator. It's important that the generator is battery-powered and ungrounded. The other thing you'll need is a test adapter or "dummy" wired as shown below. It's convenient to put it in a small cast-aluminum box using both RCA and BNC connectors.

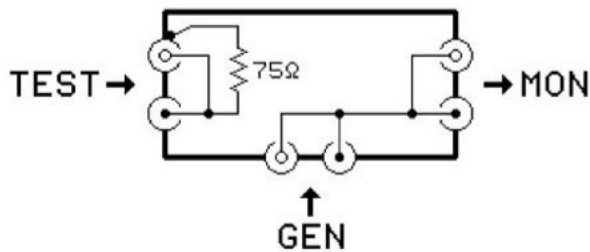

By temporarily placing the dummy and generator at strategic locations in the system, precise information about the nature of the problem is revealed. The cable between the dummy and Box B must be as short as possible and much shorter than the cable under test. **Always start at the input to the display and WORK BACKWARDS toward the signal sources.**

Each signal interface is tested using a four-step procedure:

Step 1

Unplug the cable from the input of Box B and connect the dummy/generator as shown below using a very short cable. *This test prevents any noise current, which might otherwise flow in the cable shield, from entering Box B.*

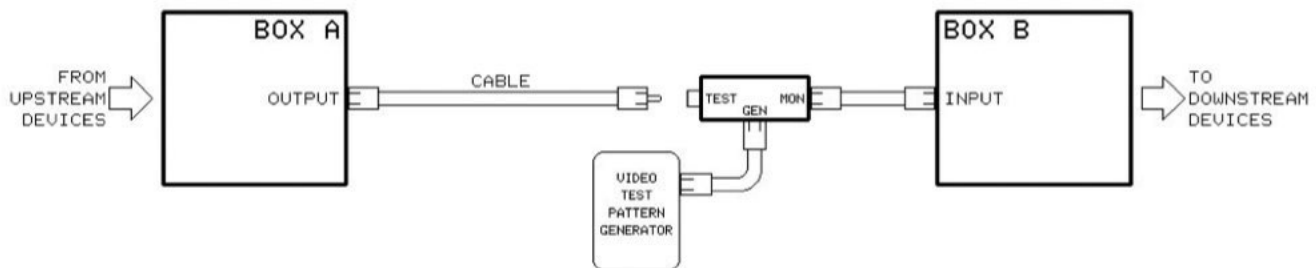

Disturbance gone? **No** — the problem is either with Box B or further downstream. Reconnect the cable and perform this test on the next downstream interface.

Yes — go to next step.

Step 2

Leaving the dummy/generator in place, plug the cable into the dummy as shown below. *This test allows noise current in the cable's shield to enter Box B.*

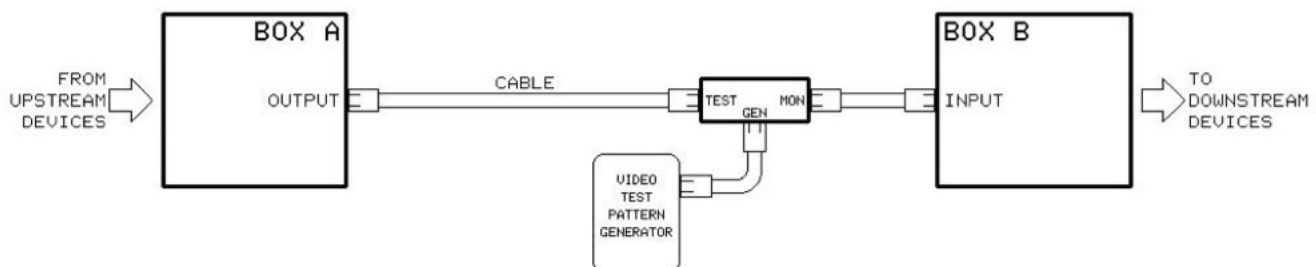

Disturbance gone? **No** — the problem may be due to common-impedance coupling inside Box B or a device farther downstream. If the input is differential (i.e., shield not directly grounded), the problem may be due to exceeding its common-mode voltage limits. If the problem is not in Box B, reconnect the cable and begin the test procedure on the next downstream interface.

Yes — go to next step.

Step 3

Remove the dummy/generator and plug the cable directly into the input of Box B. Unplug the other end of the cable from the output of Box A and plug it into the dummy/generator as shown below. Do NOT connect the dummy to Box A or let it touch anything conductive. *This step tests the cable itself for noise induced in it by magnetic or electrostatic fields. The far end of the cable is left electrically floating to prevent any other current flow in its shield.*

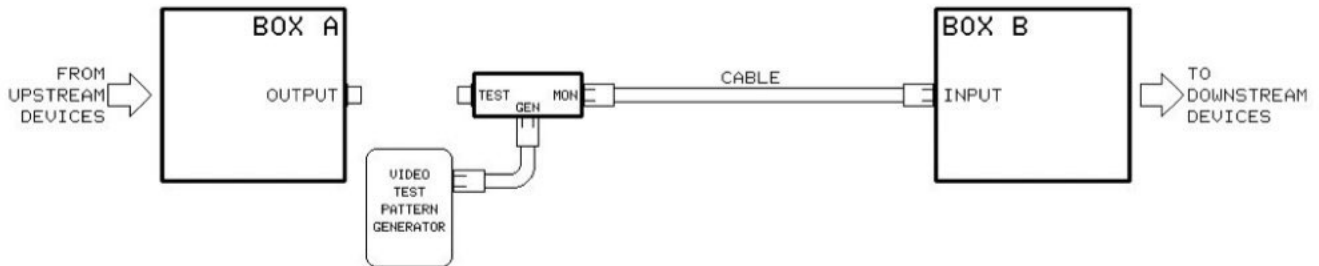

Disturbance gone? **No** — the disturbance is being induced in the cable itself. This is most often caused by a strong ac magnetic field near the cable. Re-route the cable to avoid the strong field. Sources of such fields include high-current power wiring, power transformers, and CRT displays. Electric field coupling is also possible, but *extremely* rare in video systems unless the shield itself is broken or disconnected.

Yes — go to next step.

Step 4

Leaving the dummy/generator in place on the cable, connect the dummy to the output of Box A as shown below. *This test prevents Box A from driving Box B but allows ground current to flow through the cable shield which connects them.*

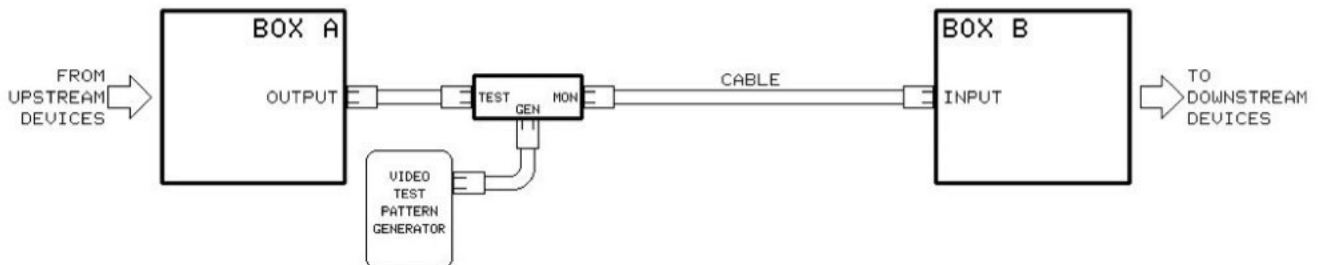

Disturbance gone? **No** — ground current is being coupled by the common-impedance of the cable shield. Install a suitable ground isolator device.

Yes — the disturbance exists on the output of Box A. Perform this four-step test on the interface between Box A and the upstream signal source.

4.3 - TROUBLESHOOTING WITH A CLAMP-ON AMMETER

An alternative test, especially useful for multi-channel or “component” video, uses a sensitive clamp-on ammeter or “leakage tester” that can measure low currents with a resolution of 1 mA or better. The one pictured costs about \$250 and is available from Mitchell Instruments as item WB380947 (www.mitchellinstruments.com). These



instruments work by sensing the magnetic field surrounding any conductor carrying current. *Signal* current in a coaxial cable generates equal but opposing fields that cancel each other. Similarly, *load* current in an ac power cable results in zero net field. Since ground loop current does not return in the same cable, the field it generates is sensed by the meter, which indicates loop current. This allows us to determine the path of, and measure the current in, ground loops by simply clamping the meter around cables — without disturbing the system in any way. In any of our schematics, we would measure the same current whether clamped around the power cable of Device A, the video cable, or the power cable of Device B.

The current required to cause a hum bar depends on the shield resistance of the cable, which is a function of both its construction and length. The following table is a general guideline:

<i>Type</i>	<i>O.D.</i>	<i>mA for 50'</i>	<i>mA for 20'</i>	<i>mA for 10'</i>
RG-11	0.285"	80	200	400
RG-59	0.242"	35	90	180
"Precision"	0.233"	26	65	130
Miniature	0.125"	17	43	86
Miniature	0.097"	9	22	43

Peak loop current is assumed to be 3 times the rms value listed and will produce a 15 mV peak voltage over the length of the cable. Typically, this results in a barely visible hum bar. Higher currents, of course, will make the disturbance more visible. Once the offending interface is located, a solution can be considered. It's clear from the table that larger-diameter cables, with more copper (and less resistance) in their shields, will tolerate higher ground loop currents.

4.4 - SOLUTIONS [25]

At power frequencies, about half of the voltage drop over the length of a coaxial cable's shield is added directly to the video signal. Therefore, the objective of any solution is to reduce this voltage drop. Obviously, it makes sense to reduce system ground voltage differences as much as possible, but this often requires expensive utility power modifications or rewiring. Likewise, use of shorter cables or types with lower shield resistance will reduce the coupling impedance. But, if none of these measures is practical, the general solution is to reduce shield current by inserting a device in the signal path that has high **common-mode impedance** (i.e., impedance to voltage appearing between its inputs and outputs). There are three basic kinds of devices to do this:

True Isolation Transformers

Like an audio transformer for unbalanced interfaces, a transformer converts the video signal itself into an ac magnetic field which then induces a replica signal in the secondary winding. Since the two windings are electrically insulated, common-mode impedance is very high at 60 Hz. Likewise, ground voltage is limited only by internal insulation and is commonly 300 volts or more.

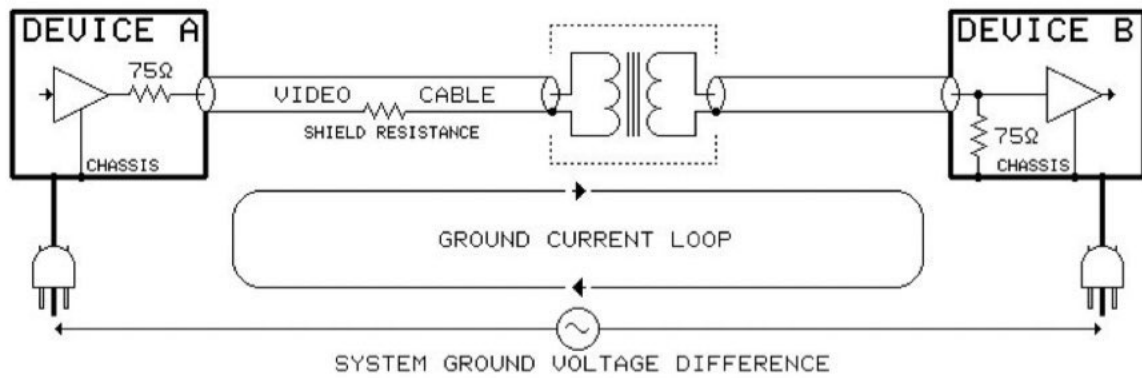

Therefore, the biggest advantage of a transformer is that loop current is reduced to negligible levels and hum rejection remains very high even with **extreme ground voltage differences** and/or **very long cables**.



Transformers are also passive (i.e., require no power) and bi-directional (passing camera control codes, for example, in the opposite direction). Their main **limitation is bandwidth**. Realizable transformers cannot have dc response and are limited to about a 1,000,000:1 frequency range. For NTSC video, poor low-frequency response can cause black level to vary from the top of the image to the bottom — this is referred to as “field-rate tilt.” Good performance in this respect requires low-frequency response extending to about 10 Hz. Therefore, practical, state-of-the-art video transformers have good response from about 10 Hz to 10 MHz, making them suitable for most *composite* or *s-video* applications.

Common-Mode Chokes

Whether called a hum eliminator, hum suppressor, humbucker, ground loop inhibitor, ground loop isolator, or (mistakenly) transformer, the most widely used solution for hum bars is the common-mode or CM choke. Although they use windings and core material like a transformer, their construction and operation is fundamentally different.

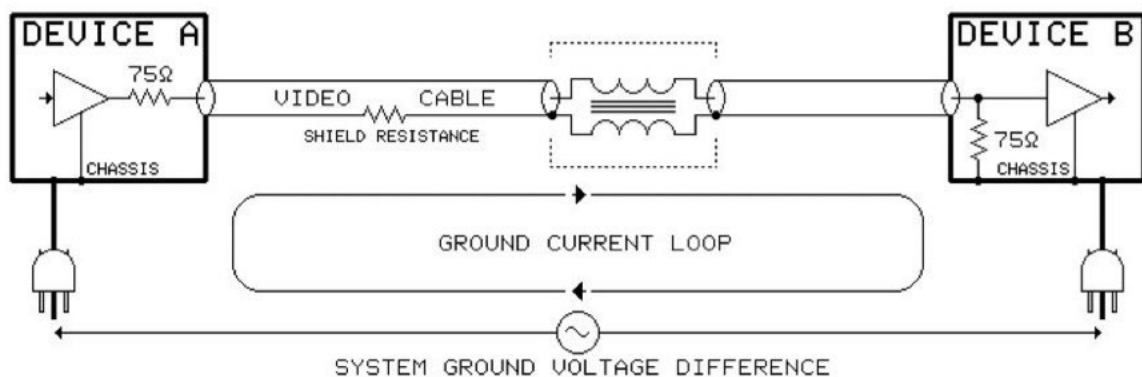

Referring to the schematic, note that the video *signal* current flows from device A to device B through the upper winding and returns through the bottom winding. Because the two windings

have the same number of turns and the same current flows through them in *opposite* directions, their magnetic fields cancel and there is *no signal-related magnetic field*. However, **ground loop** current flows through the shield and inner conductors in the *same* direction (nearly all flows in the shield since inner conductor circuit has much higher impedance). Therefore, ground loop current does produce a magnetic field in the core that reacts with the coil to create an inductor (a.k.a. choke), which determines common-mode impedance. The two “windings” are actually a single length of miniature coaxial cable. Inductance for commercial units generally ranges from 25 to 250 mH, adding 10 to 100 Ω respectively to the impedance of the ground loop at 60 Hz. As explained earlier, since the choke is now the highest impedance in the ground loop, most of the ground voltage difference will now appear between its input and output ports. However, there is a **limitation on the ground voltage** difference. The core material and number of turns used will determine the common-mode voltage at which the core will become magnetically “saturated,” causing the impedance of the choke to plummet. Therefore, ground voltage differences over a certain level will cause hum rejection to deteriorate or vanish. Commercial units vary widely in this respect! Compare specs (if they exist) carefully!

As with transformers, CM chokes are also passive and bi-directional. The major advantage of a CM choke is **wide bandwidth**. Low-frequency response extends to dc and high-frequency response is limited only by the length and type of coaxial cable used in the winding. Typical bandwidths range from 100 to 1,000 MHz, making these units suitable for high-definition TV systems. Commercial units are available in 1, 3, and 5 channel configurations for composite, RGB, RGBHV, and other multi-channel formats. The 5-channel versions can be used with breakout cables adapting them to many computer display formats as well.



Multi-Channel Common-Mode Chokes
Jensen ISO-MAX VBH-3RR and VBH-5BB

Isolation Amplifiers



Differential-In DA
Video Accessory VB/VDA-H

A differential amplifier, such as the generalized one shown in the schematic has the capability to “null” its response to common-mode voltage. Of course, at video frequencies, the circuit must be designed carefully to maintain high bandwidth. In typical designs, the common-mode impedance is about 1 k Ω . This relatively low common-mode impedance makes rejection very dependent on the driving source impedances. In a video system, these impedances vary with cable resistance (length) and accuracy of the 75 Ω source. Therefore, most

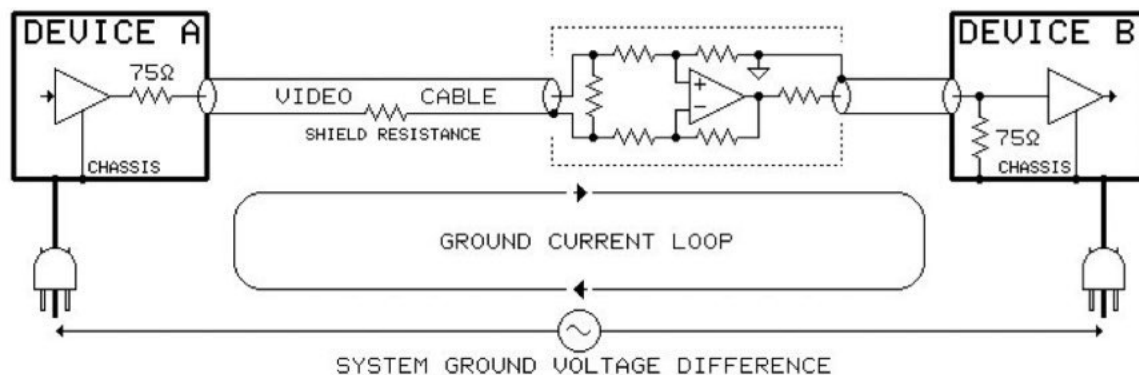

differential amplifier devices require a “trim” adjustment to achieve maximum common-mode rejection. This might be a disadvantage in portable systems where cables are frequently changed or re-routed. Although differential amplifiers require power and contain active circuitry, features such as multiple outputs and adjustable gain can be useful.

How Much Bandwidth is Necessary?

<i>Typical Source</i>	<i>Format</i>	<i>Resolution</i>	<i>Frame Rate</i>	<i>Bandwidth*</i>
VHS Videocassette	NTSC	240 “TV Lines”	30 Hz	4 MHz
Analog Broadcast	NTSC	330 “TV Lines”	30 Hz	6 MHz
Std Digital Broadcast, DVD	SDTV	480i 720 x 480 pixels	30 Hz	15 MHz
“Progressive” DVD	EDTV	480p 720 x 480 pixels	60 Hz	30 MHz
Computer	XGA	1024 x 768 pixels	60 Hz	71 MHz
HD Broadcast, DVD	HDTV	720p 1280 x 720 pixels	60 Hz	83 MHz
HD Broadcast, DVD	HDTV	1080i 1920 x 1080 pixels	30 Hz	93 MHz
Computer	SXGA	1280 x 1024 pixels	60 Hz	118 MHz

* equals $1.5 \times \text{total pixels} \times \text{refresh rate}$ (*formula courtesy of Peter Putman*) for digital formats, and $1.5 \times \text{inherent source bandwidth}$ for analog formats. For good designs, this -3 dB overall bandwidth will cause negligible resolution loss.

Which Device to Use?

Of course, performance requirements depend on bandwidth required, how much ground voltage difference is present, and the length and type of cable at the problem interface. A few points to keep in mind:

- Regardless of type, the ground noise rejection for any device will decrease as the cable gets longer. A device that works well on a 10-foot cable may produce unacceptable results with a 100-foot cable.
- Ground voltage differences may exceed the capability of a device. Maximum voltages can range from as little as 0.1 volt to as much as 1,500 volts rms (for opto-coupled units), depending on make and model.
- Coaxial cables themselves limit bandwidth. For example, -3 dB bandwidth for 100 feet of RG6 or RG11 is about 300 MHz; for 100 feet of RG59, about 150 MHz; for 1,000 feet of RG11, only 5 MHz.
- Critical information may be conspicuously absent from manufacturer’s data sheets. In many cases a key specification, such as “rejection” or “CMRR” is offered without a clue as to how the test was actually performed — or might be verified by a skeptic like me!

5 - RF INTERFERENCE AND POWER LINE TREATMENTS

5.1 - IT SURROUNDS US

Electromagnetic interference, commonly called EMI, isn't hard to find — it's actually very difficult to avoid, especially in urban areas. It can be **radiated** (through the air) and/or **conducted** (via signal or power cables) into the equipment. Common sources of radiated interference include AM, shortwave, FM, and TV broadcasts; ham, CB, remote control, wireless phone, cellular phone, and a myriad of commercial 2-way radio and radar transmitters; and medical and industrial RF devices. Electrical sparks, including welders, brush-type motors, relays, and switches are **potent** wide-band sources of radiated and/or conducted interference. Less obvious sources include arcing or corona discharge on power line insulators (common in coastal or high-humidity areas) or malfunctioning fluorescent or neon lighting. Of course, lightning (the ultimate spark) is a well known producer of momentary interference to virtually anything electronic. Because power and telephone lines also behave as huge outdoor antennas, they are often teeming with AM radio signals and other interference (see "It's Not Just 60 Hz"). But the most troublesome sources are usually inside the building and the interference is delivered through the power wiring. The offending source may be in the same room as your system or, worse yet, it may be a **part** of your system! The most common offenders are inexpensive light dimmers, fluorescent lights, CRT displays, and devices with switching power supplies.

Immunity to RFI is part of good equipment design. Although testing for RFI susceptibility is now mandated in Europe, the CE mark is certainly no guarantee of trouble-free performance. Sadly, much of the equipment available today still has very poor immunity. In audio systems, symptoms can range from actual demodulation of radio, CB, or TV signals, heard as background music or voices (buzz in the case of TV signals) to more subtle distortions, often described as a "veiled" or "grainy" quality in the reproduced audio. [11] Video, RF and data systems can exhibit a wide range of symptoms. Under unfavorable conditions, external measures may be needed to achieve adequate immunity. [29]

5.2 - SQUELCHING RF

For RF interference over about 20 MHz, ferrite "clamshell" cores are easily installed over the *outside* of existing cables and can be very effective. In most cases, they work best when placed on the cable at or near the receive end. Often they can be made more effective by looping the cable through the core several times.

If this is inadequate, or the frequency is lower (such as AM radio), a low-pass (high-frequency reject) RFI filter may be necessary in the signal line. The schematics below show sample filters for unbalanced and balanced line-level applications. For best performance and highest audio quality, use NP0 or C0G type ceramic capacitors with leads kept extremely short (well under 1/4" preferred).

The 680 μ H inductors

are small ferrite core types — current rating and DC resistance are not critical. For interference

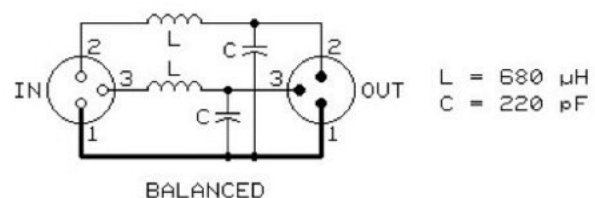
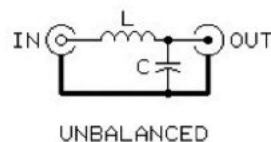

L = 680 μ H
C = 220 pF

over about 100 MHz, a ferrite bead or two on a wire may be used in place of L. In very difficult AM radio situations, it may be necessary to use higher values of C — up to about 1000 pF maximum. For the balanced filter, the inductors and capacitors should be $\pm 5\%$ tolerance or better. These filters generally work best at the receive end of the cable, inputs usually being more susceptible to RF than outputs - although this is not always the case. If used for low-level microphone lines, miniature toroid inductors should be used to prevent possible hum pickup from stray ac magnetic fields.

5.3 - TECHNICAL GROUNDING

So-called “technical” or “isolated” grounding schemes can *sometimes* reduce electrical noise in the safety ground system. It is most applicable in situations where **conduit may come in contact with building steel, water pipes, gas pipes, or other structures** which may be grounded and carrying noisy currents. Special insulated ground or “IG” outlets (generally orange in color) are used, which intentionally insulate the green safety ground terminal from their mounting yokes or saddles. Therefore, safety grounding is not provided by the “J-box” and conduit, but by a separate *insulated* green wire which must be routed back to the electrical panel *alongside the white and black circuit conductors to keep inductance low*. Most often, wiring is not “daisy-chained” to outlets on the same branch circuit, so noisy leakage current from one device has less coupling to others on the same branch circuit. However, inductive coupling from phase conductors to the ground conductor (a major source of ground voltage differences between outlets) is **not** reduced. Technical grounding practices are covered by NEC Article 250-74 and its exceptions.

5.4 - POWER ISOLATION, FILTERS, AND “BALANCED POWER”

Because system noises are most frequently coupled from the power line, solutions which somehow “cleanse” or “purify” it have great intuitive appeal. However, in this author’s experience, such treatments usually produce marginal improvements, if any. Generally, the most cost-effective solution is to identify and eliminate the ground loops or other problems which allow the noise to couple into signal paths. This approach solves the real problem. **Treating the power line to get rid of noise is like using a shotgun instead of a silver bullet to target the problem!**

First, when any line filter, conditioner, or isolation transformer is used, Code requires that the device as well as its load still be connected to safety ground as shown. Because transformer winding capacitances and/or filter capacitors divert additional 60 Hz and high-frequency noise currents into the safety ground system, they *frequently aggravate the problem they claim to solve*.

Second, the touted noise attenuation figures for virtually all these power line devices are very unrealistic. Measurements are made with all the equipment (generator, detector, and device under test) mounted on a large metal **ground plane**. Although the resulting specs are impressive, they simply *don’t apply* to performance in a real-world situation where grounding is via safety ground wires or conduit. But such devices **can** be very effective when installed at the power service entrance, where all system safety grounds are physically very close to a common reference point (usually the ground rod).

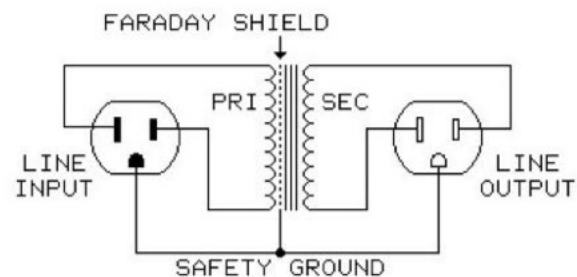

Power Isolation Transformer

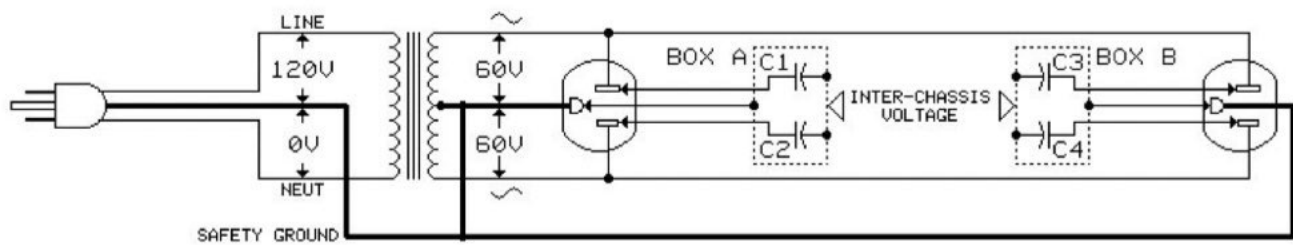

Balanced Power Attempts to Cancel Ground Current with Symmetrical Voltages

“Balanced power” or, more properly, *symmetrical* ac power is a seductively appealing concept. However, its proponents often *mistakenly assume* that equipment has precisely matched capacitances from each leg of the power line to chassis (C1 and C2 or C3 and C4) when they explain how it itcancelsly ground noise. Of course, *if this were true*, capacitive noise currents from each 60-volt leg would then be of equal magnitude and opposite polarity, and completely cancel. But the assumption is **not** valid for the overwhelming majority of real-world equipment, whose capacitance ratios are often 3:1 or 4:1. Even balanced power proponents admit that **actual noise reduction is usually under 10 dB and rarely exceeds 15 dB** (recall that 10 dB noise reductions are generally described as “half as loud” by listeners). And it’s not likely that equipment manufacturers will ever adopt expensive power transformers with capacitively “balanced” primary windings or RFI filters that use precision capacitors.

But balanced power can make cost-effective sense in *some* systems. One example might be a video duplication facility having 50 unbalanced (coax) video interconnects and hum bars at an unacceptable level of -30 dB. Here, the 10 dB improvement likely from balanced power (or “technical grounding” for that matter) might reduce the hum bars to a more acceptable level of -40 dB, effectively solving the problem. But, for audio, a 10 dB improvement will rarely make the difference between unacceptable and acceptable performance! **In reality, many of the benefits often ascribed to “power treatment” schemes are simply due to plugging all system equipment into the same outlet strip or dedicated branch circuit. For obvious reasons, this is always a good idea!**

A simple outlet wiring error that swaps the neutral and safety ground conductors allows *load current* to flow in the safety ground wiring. The abnormally high voltage drops created can cause **severe ground noise** in systems using safety-grounded equipment. This error *cannot* be found with simple outlet testers, but measuring current at points A, B, and C with a clamp-on ammeter will clearly reveal it. [30]

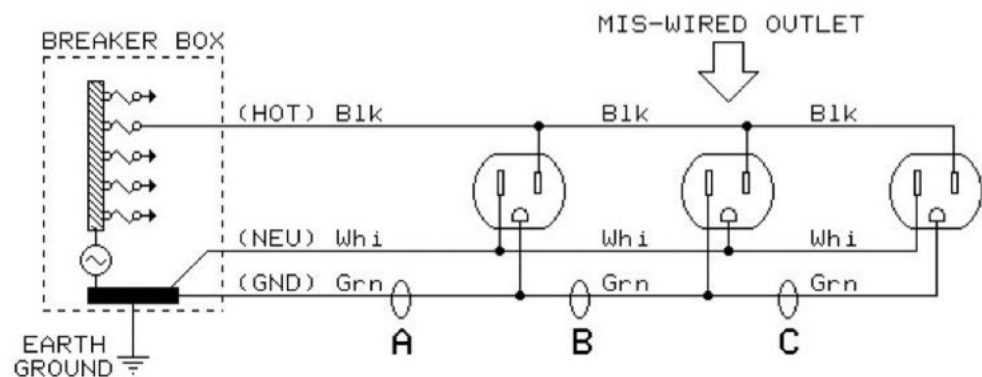

5.5 - SURGE SUPPRESSION CAUTIONS

Over the years, fear, horror-stories, and junk science have been used to sell a host of surge protection devices. However, thoughtless use of **conventional** surge suppressors at outlets can

actually increase the risk of equipment damage! Ordinary suppressors use three MOV (metal-oxide varistor) devices that divert surge energy into the safety ground system. As shown in the following drawing, during an actual surge or spike very high voltage differences are created in the safety ground system. When signal lines connect devices on different outlets or branch circuits, interface circuits are often damaged when exposed to these high voltages. [31]

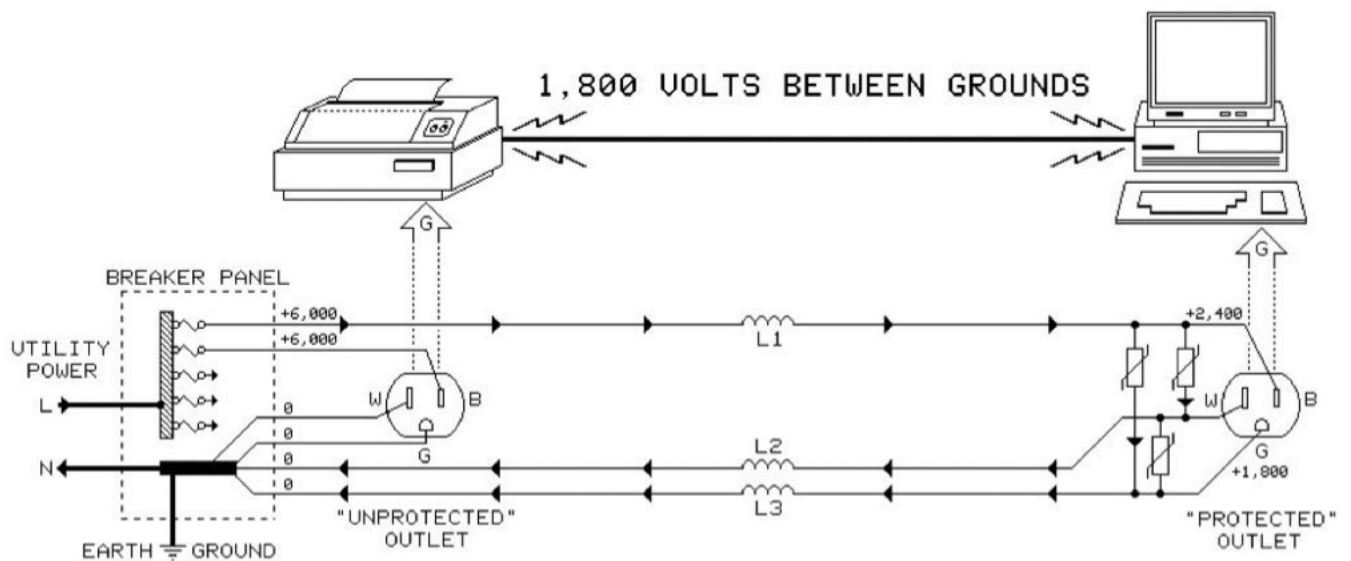

To protect against lightning induced power line surges, protective devices need to be installed **at the main service entry**. For protecting sub-circuits or pieces of equipment, I highly recommend **series-mode** suppressors, such as those made by Surge-X. Rather than diverting surge energy, series-mode devices present a *high impedance* to the surge that limits its current and slowly dissipates its energy. They don't dump noise or potentially damaging high currents into the safety ground system.



Series-Mode Surge Protection
Surge-X SX-2120



Series-Mode Protection for Branch Circuit
Surge-X SX-15NE

REFERENCES:

- [1] Gerke, D. and Kimmel, W., *The Mysteries of Grounding*, IEEE EMC Society Newsletter, Summer 1998, pp. 13-14.
- [2] Whitlock, B., *Ground Rods: Magical Noise Sinks?*, Sound & Video Contractor, November 2000, pp. 102-103.
- [3] Whitlock, B., *Surge Protection: The Enemy Within*, Sound & Video Contractor, July 1999, pp. 94-95.

- [4] Morrison, R. and Lewis, W., *Grounding and Shielding in Facilities*, Wiley-Interscience, New York, 1990, pp. 47-49.
- [5] Model 34000, Technology Research Corp., Clearwater, Florida, Tel (727) 530-9580, www.trci.net.
- [6] Hiser, S., *1997 Electrocutions Associated with the Use of Consumer Products*, United States Consumer Products Safety Commission, 2000, www.cpsc.gov
- [7] Mah, J. et al, *1997 Residential Fire Loss Estimates*, United States Consumer Products Safety Commission, 2000, www.cpsc.gov
- [8] Morrison, R., *Solving Interference Problems in Electronics*, First Edition, John Wiley & Sons, 1996, p. 35.
- [9] Morrison, R. and Lewis, W., *Grounding and Shielding in Facilities*, Wiley-Interscience, New York, 1990, pp. 168-169.
- [10] Whitlock, B., *Hum & Buzz in Unbalanced Interconnect Systems*, Application Note AN004, Jensen Transformers, 1996, www.jensentransformers.com..
- [11] Jensen, D. & Sokolich, G., *Spectral Contamination Measurement*, Audio Engineering Society 85th Convention, 1988, Preprint #2725.
- [12] Keltz, A., *Unbalanced vs. Balanced Lines and Cables*, Technical Articles, Whirlwind USA
- [13] Ott, H., *Noise Reduction Techniques in Electronic Systems*, Second Edition, John Wiley & Sons, 1988, p. 116.
- [14] *Reference Data for Radio Engineers*, Fifth Edition, Howard W. Sams, 1972, p. 11-1.
- [15] Whitlock, B., *A New Balanced Input Circuit for Maximum Common-Mode Rejection in Real-World Environments*, Audio Engineering Society 101st Convention, 1996, Preprint #4372, available at www.jensentransformers.com.
- [16] Muncy, N., *Noise Susceptibility in Analog and Digital Signal Processing Systems*, Journal of the Audio Engineering Society, June 1995, pp. 435-453.
- [17] Brown, J. and Whitlock, B., *Common-Mode to Differential-Mode Conversion in Shielded Twisted-Pair Cables (Shield-Current-Induced Noise)*, Audio Engineering Society 114th Convention, 2003.
- [18] Windt, J., *An Easily Implemented Procedure for Identifying Potential Electromagnetic Compatibility Problems in New Equipment and Existing Systems: The Hummer Test*, Journal of the Audio Engineering Society, June 1995, pp. 484-487.
- [19] Fielder, L., *Dynamic Range Issues in the Modern Digital Audio Environment*, Journal of the Audio Engineering Society, May 1995, pp. 322-339.
- [20] Pease, R., *Troubleshooting Analog Circuits*, Butterworth-Heinemann, 1991.
- [21] Whitlock, B., *Losing the Hum Bar, Part 1 - Troubleshooting*, Sound & Video Contractor, May 2002, pp. 26-30.
- [22] Whitlock, B., *Balanced Lines in Audio Systems: Fact, Fiction, and Transformers*, Journal of the Audio Engineering Society, June 1995, pp. 460-462.
- [23] Ott, H., *op. cit.*, p. 105.
- [24] Morrison, R., *Noise and Other Interfering Signals*, John Wiley & Sons, 1992, p. 55.
- [25] Whitlock, B., *Losing the Hum Bar, Part 2 - Product Solutions*, Sound & Video Contractor, July 2002, pp. 20-26.
- [26] *PolyPhaser Model IGA-90V*, PolyPhaser Corporation, Minden, Nevada, (800) 325-7170, www.polyphaser.com.
- [27] Whitlock, B., *Interconnection of Balanced and Unbalanced Equipment*, Application Note AN003, Jensen Transformers, Inc., 1995.
- [28] Hay, T., *Differential Technology in Recording Consoles and the Impact of Transformerless Circuitry on Grounding Techniques*, Audio Engineering Society 67th Convention, 1986, Preprint #1723.
- [29] Whitlock, B., *Understanding and Controlling RF Interference*, Sound & Video Contractor, February 1999, pp. 78-80.
- [30] Whitlock, B., *Neutral Ground*, Sound & Video Contractor, June 2001, pp. 24-26.
- [31] Whitlock, B., *Surge Protection: The Enemy Within*, Sound & Video Contractor, July 1999, pp. 94-95.
- [32] Muncy, N., *The Benefits of Surgex Surge Suppression*, www.surgex.com/pdf/surgex11001.pdf.

SUGGESTED READING FOR FURTHER STUDY:

1. Whitlock, B., *Handbook for Sound Engineers*, 3rd Edition, Focal Press, 2001, Glen Ballou, editor, Chapter 11, *Audio Transformers* and Chapter 32, *Grounding*. (now available in paperback)
2. Morrison, R. & Lewis, W., *Grounding and Shielding in Facilities*, 1st Edition, John Wiley & Sons, 1990.
3. Morrison, R., *Solving Interference Problems in Electronics*, 1st Edition, John Wiley & Sons, 1996.

Revised 27 Aug 2008

Important Note - The mention of specific products and/or the inclusion of their images herein is for the purpose of illustration of examples only and does not imply endorsement by the author.

Romex® is a registered trademark of General Cable Industries, Inc.

ISO-MAX® is a registered trademark of Jensen Transformers, Inc.

InGenius® is a registered trademark of THAT Corporation

ExactPower® is a registered trademark of Atlantis Power Quality Systems, Inc.

Jensen Transformers, Inc.

9304 Deering Avenue
Chatsworth, California 91311

Internet: www.jensen-transformers.com or www.iso-max.com

Phone: (818) 374-5857 (9 AM - 5 PM PST, closed Fridays)

Fax: (818) 374-5856 (7 days/24 hours)

E-mail: info@jensen-transformers.com

Bill Whitlock e-mail: whitlock@jensen-transformers.com