

## Introduction

The appendix has four sections: SMPTE Made Simple, Setup Quick Reference Guide, Cabling Reference Guide, Error Messages, and Glossary.

## SMPTE Made Simple

Provides basic information and various applications using SMPTE time code.

## Quick Reference Guide

A graphical chart of the Micro Lynx Setup Options.

## Cable Reference Guide

Provides setup and cabling information to help you configure and use the Micro Lynx.

## Auto Serial Transport Table

Contains a list of the serially controlled transports currently recognized by the transport menu setting AUTO Serial TRANSPORT.

## Key Combination Guide

Provides Key and Key Combination Identification Numbers for “stuck key” errors.

## Glossary

An alphabetic list of terms used during the discussion of the Micro Lynx.



# SMPTE Made Simple

## The Time Code Tutor from TimeLine

---

### Introduction

When the television broadcast industry moved from film and live performance to prerecorded video production, a method was required to reliably synchronize and edit the new medium. Historically, film rushes were lined up at the clapper board and rubber stamped with footage numbers, and by default film was mechanically held in sync by the sprocket holes. Unfortunately, video tape had neither of these attributes. This created a problem of how to get the music, pictures, dialogue, and effects all to begin and run at the same time.

The solution was SMPTE time code. SMPTE is a signal with specific address information that can be recorded on audio or video tape and used to position them, accurately.

### Why SMPTE?

In 1971, the Society of Motion Picture and Television Engineers chose **SMPTE** to be the industry standard for synchronization. It became officially known as SMPTE/EBU Time Code when the society was joined by its' overseas counterpart, the European Broadcast Union (EBU). Since it is quite a mouthful, most people just say SMPTE.

### What Can You Do with SMPTE?

There are hundreds of uses for SMPTE time code in every branch of audio production. They include records, video, film, advertising and industrials. Let's start with the how and why of some of the most basic applications.

## Synchronizing Multiple Audio Machines

Imagine you are a recording engineer. You've just used up all the available tracks on your multitrack machine, but your project is nowhere near completion. How are you going to get some extra tracks? Use a second multitrack recorder.

The question is, "how do you lock the two machines so that the music plays back in perfect synchronization – first time, every time." You *could* try to hit the Play buttons on both machines at exactly the same moment and then cross your fingers, but the odds of this working even once are *very* slim.

The correct solution is to use SMPTE time code *AND* a TimeLine synchronizing system. It works like this: a TimeLine Lynx or Micro Lynx generates time code that is recorded onto the audio tapes. The time code is then used as a common reference point, the "glue" that holds the two machines in sync.

On playback, a SMPTE time code reader reads time code from one tape recorder and passes the timing data to a synchronizer connected to the other tape recorder. Based on this incoming time code, the synchronizer regulates the playback speed of the slave so that it always stays in perfect sync with the master.

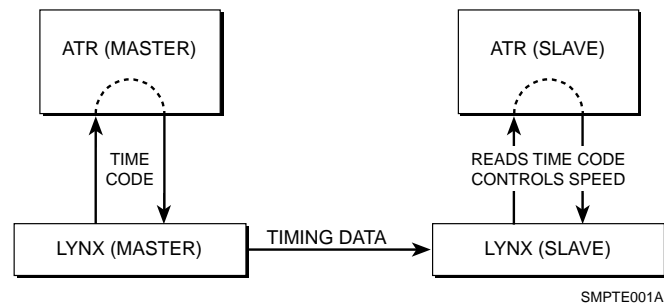

**Figure Appendix A-1. Basic SMPTE Time Code Setup**

This simple example is the basis for all SMPTE applications. For instance, if you are locking to film or video using a digital audio workstation or a sequencer, you'd just substitute the appropriate controlling device to suit the equipment for that application.

## Locking to Picture

Suppose you have footage on videotape and you need to create an audio track to go with it. It could be music, dialog, effects, or all three. How do you lock the sound to picture?

Use SMPTE and a Micro Lynx or two Lynx modules, exactly as described in the previous audio example. SMPTE works just as well with video as it does with digital or analog tape. You can use SMPTE to lock video to analog, digital to analog, in fact, just about anything to anything; even sound sources that don't use tape.

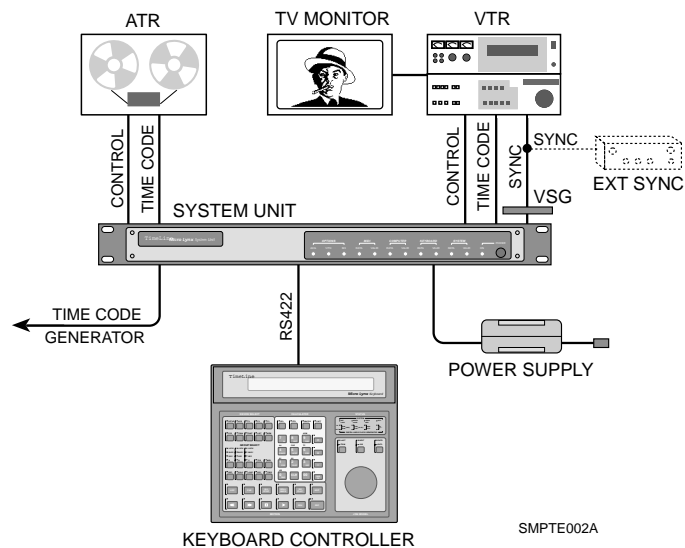

Figure Appendix A-2. Synchronize to Video

## Mix Automation and More

If you have a MIDI sequencer and some synthesizers that you want to lock to your multitrack tape or to picture, the TimeLine Micro Lynx can translate SMPTE time code into the MIDI data that the sequencer needs to lock to tape.

SMPTE can be used to control just about anything that has micro processor intelligence – and what piece of audio gear doesn't these days? For instance, mixing console automation will run to time code and can therefore be locked to tape and other time code devices for complete system automation.

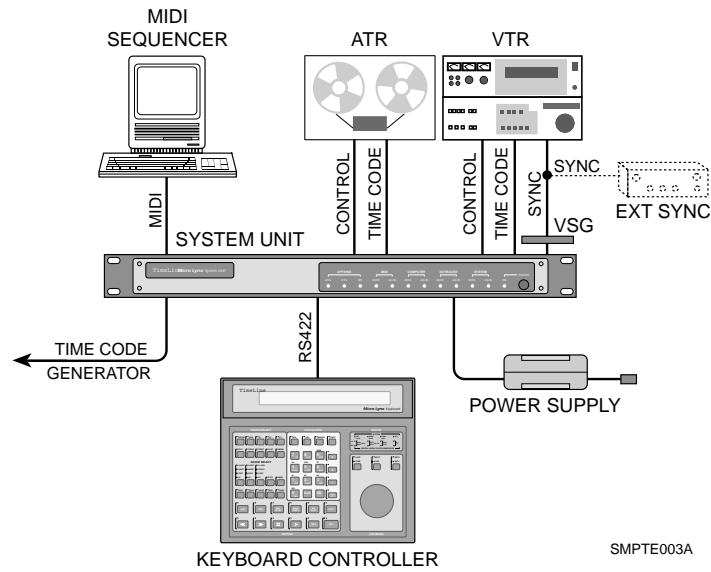

Figure Appendix A-3. MIDI Sequencer and Time Code

### Complete Systems

The ultimate SMPTE application is the complete studio system. Just as two devices can be locked to a common time reference, so can a whole roomful: tape machines, consoles, synthesizers, effects processors, and hard disk recorders. With an efficient controller like the Micro Lynx Keyboard, all of these different machines can be operated as easily as a single set of transport controls. Later, we'll explain how SMPTE is used to build large, multi-machine networks for video editing and music recording.

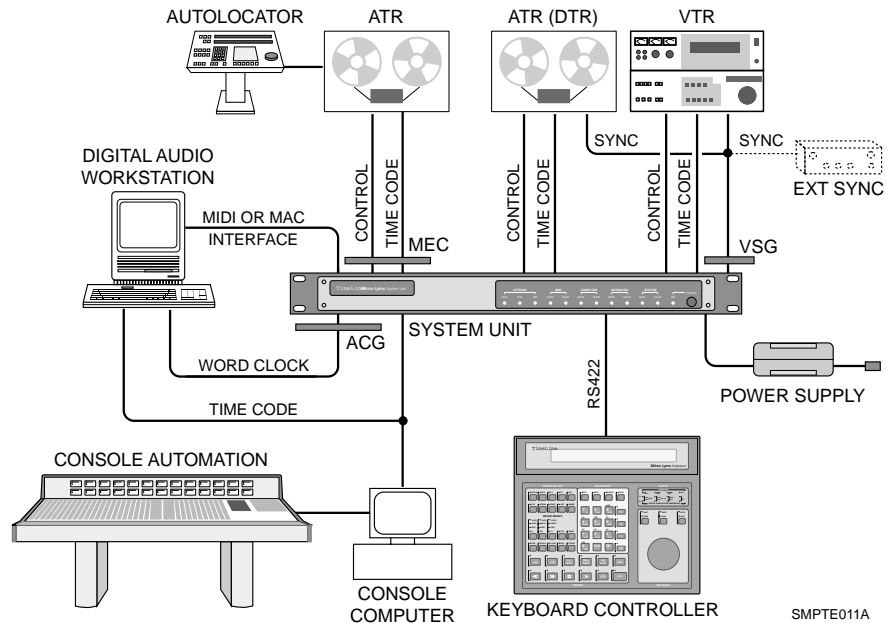

Figure Appendix A-4. Complete Studio System

## How Does SMPTE Do It?

If you know precisely where a piece of program is and how fast it is playing, then it is possible to use this information to control other machines so that they are all in the right place at exactly the same time. SMPTE does just this, it is an absolute timing reference that indicates both the speed and position of a tape as it travels across a tape machine transport.

### What You Can Do with a Speed Reference

Many pre-SMPTE sync codes could only indicate speed. The most widely used was control track or pilot tone. Pilot tone is an audio signal derived from a stable source, historically 60 Hz AC wall current. By reducing the voltage with a suitable transformer, the resultant continuous sine wave could be recorded on tape.

Machine speed is normally regulated by monitoring tach pulses from the tape machine's capstan motor. They indicate how many times the capstan revolves in a given time interval, just as an automobile's tachometer indicates how fast an engine is turning.

When playing a tape with pilot tone back, the sine wave on tape is compared with a reference sine wave coming from the wall current or some other guaranteed signal.

If the tape slows down, the frequency of the pilot tone, or the number of cycles that tick by each second, will decrease. If the tape speeds up, the frequency will increase. A controlling device, tied into the tape machine's capstan motor, senses the difference between the reference tone and the pilot tone on tape; and varies the speed of the tape machine motor to make the two match up again.

This process of matching tape machine speed to a stable reference is called resolving. The two sets of sine waves are brought *in phase* with one another, so they match up perfectly, peak for peak, trough for trough. Which is why this is sometimes called phase locked.

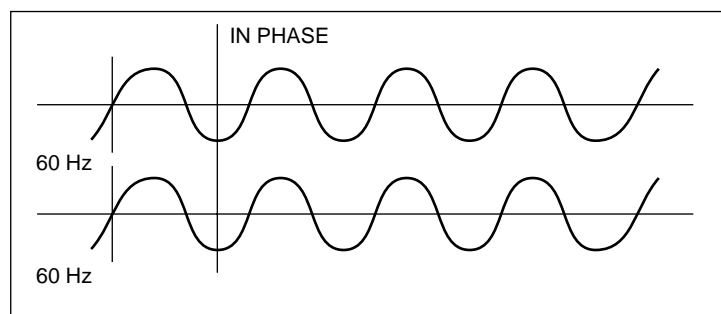

SMPTE004A

Figure Appendix A-5. Two Sine Wave Signals in Phase

Just as pilot tone on one tape machine is made to match the reference source, it can also be made to match pilot tone on a second master tape machine. Thus, pilot tone can be used to synchronize the speed of the two tape machines.

**However, There Is a Problem:** One sine wave looks exactly like another. While the slave machine can phase lock with the master, it has no way of knowing whether the master is playing the first verse or the third chorus or if the master is three-and-a-half seconds into a scene or right at the beginning. As a tool for synchronization, pilot tone is severely limited. The same is true for other *speed only* sync codes such as Frequency Shift Key (FSK) and Din Sync.

To work, master and slave must be carefully lined up at the beginning of playback and there's no way to run the machines accurately to the middle of the program material since the slave never knows where the master is, *only* how fast it is playing.

## SMPTE: What You Can Do with a Speed and Position Reference

This is where SMPTE time code enters the picture. As we said, SMPTE indicates not only tape *speed*, but also tape *position*. SMPTE time code is a complex digital signal, equivalent to the simple, analog pilot tone signal with a unique number assigned to each cycle of the sine wave.

Time code is recorded onto tape as an audible signal – a rapid-fire series of *blips*. These blips are “read” by a microprocessor as a unique number: an address, consisting of separate numbers for hours, minutes, seconds and fractions of a second, called frames.

So, if you have a gunshot at the climactic scene of a suspense melodrama, SMPTE tells you exactly where the gunshot “lives;” what its address or location is on tape. SMPTE can say, “This gunshot occurs one hour, 31 minutes, 12 seconds and 19 frames into the film.” This means you can shuttle to the exact spot on tape where that gunshot occurs, and replace the existing blast with a more convincing sample; one the sound effects engineer just acquired.

Think of what that means: the master machine can find *ANYTHING* on a tape, and all slave machines will chase the master to that very same spot. At this point, we're a long way from just locking one faceless sine wave with another and rolling from the top. We've moved into the realm of position accuracy.

## Anatomy of a SMPTE Frame

A SMPTE frame or word consists of 80 bits that convey SMPTE's message of hours, minutes, seconds, and frames. Each bit is represented by a binary '1' or '0' that is specifically encoded for recording onto tape. The method used is called biphase encoding. This coding reverses the signal polarity halfway through a bit to represent a '1' and leaves the bit polarity unchanged to represent a '0'. A continuous string of these 80-bit words is recorded linearly along the tape to form the time code.

Let's look at the jobs the bits perform. Each frame is broken up into 16 groups of 4 bits and a 16-bit sync word.

- Eight 4-bit groups are assigned to the hours, minutes, seconds, and frame number.
- Eight 4-bit groups are user bits. They are reserved for information such as ID, reel numbers, session, dates or another time code number.
- The remaining bits form a sync word, to provide direction information and mark the end of the 80-bit frame.
- The time code reader uses the direction sense bits to determine whether the tape is running forwards or backwards.
- The sync word is a series of preset 1's that allow the speed and phase of two time codes to be read and compared by the Lynx or Micro Lynx module to establish synchronization.

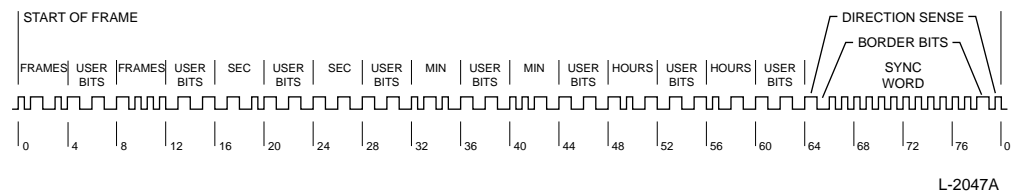

**Figure Appendix A-6. Time Code Address**

SMPTE words, one for each frame, are recorded along the length of the tape; hence the name Longitudinal Time Code (LTC). The code's design and organization make it suitable for use over a very wide range of play speeds, both forwards and backwards.

The frequency of the LTC signal is always proportional to the tape speed. However, the signal cannot be read in stop or freeze-frame mode. Consequently video frequently uses another form of time code: Vertical Interval Time Code (VITC), which can be reliably read in stop and at very slow play speeds.

## Time Code Formats

There are 60 minutes in an hour; 60 seconds in a minute, but how many frames are there in a second? Frame rate is the term used to express the number of frames-per-second in SMPTE time code. Frame rate was originally measured as one-half the power line frequency.

Since there are different power line frequencies in the U.S. and Europe, time code has several different formats, defined by the frame rate used in each country.

### National Television Standards Committee (NTSC)

Wall current in the U.S. has a frequency of 60 Hz, making 30 frames-per-second the standard frame rate for American black and white television.

### Phase Alternate Line (PAL)

In Europe, the standard wall current frequency is 50 Hz. Thus we have another format: 25 frames-per-second or the PAL format, the standard for European color television.

### Drop Frame (DF)

What about American color TV? When it was invented by RCA, they reduced the American black and white frame rate of 30 frames-per-second to 29.97 frames-per-second, to allow both color encoding and compatibility with existing black and white television sets. This became the standard color TV format for America.

The problem is that 30-frame time code running at this rate measures slightly slower than real time.

60 sec x 30 frames/sec	=	1800/min x 60 min/hr	=	108,000 frames
60 sec x 29.97 frames/sec	=	1798.2/min x 60 min/hr	=	<u>107,892 frames</u>
		Difference	=	108 frames

So for every hour, by the clock on the wall, the time code is 108 frames short. Just a few frames off might disastrously make your lead guitarist end his solo two chords early! To correct this, a time code format called Drop Frame (DF) was developed. Drop frame skips the first two frame counts in each minute (with the exception of minutes 00, 10, 20, 30, 40, and 50) to force the time code to match the clock time.

## Film

Film is our final consideration. It has run at a frame rate of 24 frames-per-second ever since Thomas Edison invented it. Although this is a “non-standard” time code, it is sometimes used in the field.

### Different Frame Rate Formats

In summary, the important thing to remember is that SMPTE conveys two pieces of information: *tape speed* and *tape position*.

Frame rate, is the speed at which the code will run, and frame type (30/DF/25/24), is the way in which frame positions are counted.

**30.** Thirty frames-per-second can be drop frame (DF) or non-drop frame. If drop frame is selected, then the actual frame count is reduced by 108 frames-per-hour.

**25.** Twenty-five frames-per-second is the European standard.

**24.** Twenty-four frames-per-second is the film standard.

Table Appendix A-1. Frame Rate Formats

Counting Rate (Hz)	Counting Method (Frames-per-Second)	Displayed Time Accuracy	Application
24	24 frame	Real Time	Motion pictures and film
25	25 frame	Real Time	EBU standard for European television
29.97 <sup>1</sup>	30 drop frame <sup>3</sup>	Real Time	NTSC standard USA & Japan
29.97 <sup>1</sup>	30 non-drop frame <sup>4</sup>	0.1 % slow	USA & Japan
30.00 <sup>2</sup>	30 drop frame <sup>3</sup>	0.1 % fast	Non-standard
30.00 <sup>2</sup>	30 non-drop frame <sup>4</sup>	Real Time	USA & Japan

<sup>1</sup> 29.97: Generated by all “color television” sync generators (i.e., almost all sync generators built after 1970). This is the speed at which a “black burst” signal runs (not to be confused with “black & white”). It is a standard color signal with a “color of black.” *Use this* as your standard frame rate unless you are an expert and have a reason not to.

<sup>2</sup> 30.00: Usually available only in “internal crystal mode” of a time code generator, or from black & white television sync generators. *Don't use* this non-standard speed unless you are an expert and have a good reason. This is sometimes used in conjunction with motion picture film systems.

<sup>3</sup> Skips 108 frames/hour at regular intervals.

<sup>4</sup> Many users prefer 30 (full frame) counting because no numbers skip in the counting sequence, even though the elapsed time accuracy at 29.97 frame rate is slightly different from real time.

# VITC

Vertical Interval Time Code (VITC) is another form of SMPTE that is used only with video, and is printed horizontally at the beginning of each field, as part of the video signal. Longitudinal Time Code (LTC) is printed linearly along an audio track.

Unlike LTC, VITC cannot normally be added to a video tape after the picture has been recorded. It must be recorded with the video signal when the original tape is generated.

Each picture has 525 lines (625 for PAL). To facilitate picture clarity, the lines are divided into two interlaced (odd and even) fields. This means that 262 even lines are scanned, then the scanner returns to the beginning of the picture and scans the 263 odd lines. As the lines are scanned, a number of lines at the top and bottom of the picture are never displayed; they are “blank” space. These lines are available to store information. VITC is recorded on two of these spare lines, at the top of each field. One complete VITC data word is recorded on each line.

VITC uses a 90-bit data word instead of the 80-bit data word used by LTC. The extra bits are used to provide error correction and to prevent bad time code values from being read. VITC allows accurate reading of tape position even when the tape is stopped in freeze frame, which is something that LTC can't do. VITC is often used in conjunction with LTC in applications that involve both audio and video.

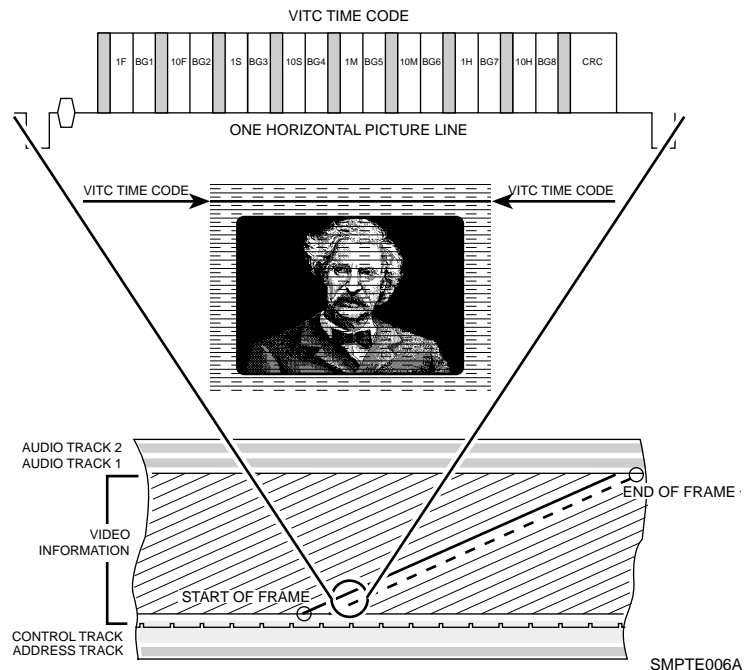

Figure Appendix A-7. Video Tape and VITC Time Code

## SMPTE, MIDI and MTC

MIDI is not the same as SMPTE, even though both are binary codes. They each carry very different types of information.

SMPTE, as we've seen, answers the questions "Where are we," and "How fast are we going?" MIDI however, answers an equally vital but totally different question, "What do we do now?" It answers that question for synthesizers, drum machines, and other electronic music devices. MIDI is the language that a computer uses when it tells a synthesizer, "Play middle C, play it mezzo forte, and play it ... *now!*"

But when is *now*? If we're talking about playing back an electronic composition in concert, *now* is a relative term. *Now* might be the third beat of the fourteenth measure, and whether that beat hits at 10:31 or 10:32 PM is something no one usually notices. However, if that beat has to coincide with the cocking of an assassin's pistol in a feature film thriller, or coincide with a soul-wrenching wail from a vocalist on audio tape, it becomes necessary to pin *now* down.

The traditional way is to slave a MIDI sequencer to SMPTE. Many popular sequencers can read incoming SMPTE and lock their musical tempos (their beats-per-minute) to the time code.

It works beautifully, but it leaves the film or TV composer with the awkward situation of flitting continually between two highly dissimilar sets of numbers. While his sequencer counts beats and measures, his work print, cue list, director's instructions and everything else that pertains to the visual side of the equation, all talk of hours, minutes, seconds and frames. The two sets of numbers never coincide neatly, forcing the composer to pull all sorts of tricks on his sequencer.

MIDI is a computer code that uses 8-bit data words or bytes that cannot contain SMPTE's 80-bit word. This is the reason for the invention of MIDI Time Code (MTC). MTC, quite simply, takes SMPTE time code and translates it into the MIDI data format. To translate SMPTE into MIDI, the MIDI time code format transmits a MTC message byte every 1/4 frame. The first two 1/4 frame bytes contain only the frames. The next two MTC bytes convey the seconds, the next two the minutes, the next two the hours, and so forth.

This whole process takes exactly two SMPTE frames to complete. As soon as one complete SMPTE address is transmitted, the MTC generator updates the time code by 2 frames and starts again.

The TimeLine Micro Lynx and Lynx System Supervisor Unit can take SMPTE from a master tape and generate MTC. Thanks to this, the film/TV composer can now use a cue-sheet style program, as well as conventional music, and if desired, deal exclusively in the realm of hours, minutes, seconds, and frames.

Although SMPTE and MTC are not the same thing, they make a powerful combination when the Micro Lynx or System Supervisor puts them together.

## Using SMPTE

Any SMPTE time code application involves three basic functions. First you need a generator to produce the actual SMPTE signal that goes onto tape. Second, you need a reader to read the SMPTE time code from tape. Finally, there's the job itself – what you want to accomplish.

SMPTE can be used with a resolver, to ensure that a single tape machine runs at a consistent speed. It can also be used with an autolocator that stores a number of SMPTE addresses in memory and chases to those addresses on command, or when you want to lock one or more devices to a master tape machine with a synchronizer.

In the early days, a different device was quite often required to perform each of these functions. Today, TimeLine has several products that perform them all: the Lynx Time Code Module with a Keyboard Control Unit, compact, high-end, high performance units; and the Micro Lynx, a high performance project or smaller studio system.

## Things To Know About Generating Time Code

Time code, generated and striped on tape, must ultimately be played back and read, so you must determine the optimum level for your master tape before generating the time code. Master tapes are generally printed at about -6 dB. If you print code at too low a level, the reader will have trouble reading it, but if you print it too hot, it will bleed audibly onto adjacent tracks. For this reason, many engineers leave a guard band – a blank track next to the time code track – even when printing at the correct level. To remove the need for leaving two blank tracks (one track on either side), time code is usually printed on the outermost track in multitrack formats (i.e., track 24 on a multitrack machine).

In video and digital audio applications, always make sure that the time code generator and machines are properly referenced together when printing time code. Your generator must be connected to the same external video sync signal as the video or digital machine, otherwise, when synchronizing, the video machine's will start off in the right place, then slowly drift apart.

With digital audio machines, the sample rate or word clock must be locked to the time code. This is normally done by using a video sync signal as a common timing reference for the generator and the digital machine. Set both to "EXT VID" before printing time code. If you do not have a sync pulse generator, the Micro Lynx Video Sync Generator (VSG) option card can be installed and used to generate a referenced composite sync signal for your video or digital machine.

Specific types of video sync include black burst, color bars and composite. These video sync signals are often collectively called *house sync*, or the signal that's universal throughout the production facility or house. To reference your generator to video sync, set it to "EXT VID" mode and connect a video sync signal. This ensures that the tapes you are striping will have a common reference and on playback will sync properly.

## Reshaping Time Code

Reshaping, or cleaning up the time code signal, should always be performed when dubbing time code from one tape to another. If you simply copy time code from one tape to another without reshaping, it will deteriorate quickly due to generation loss and will eventually become unusable. Reshaping is not recommended when the time code on tape has begun to deteriorate badly.

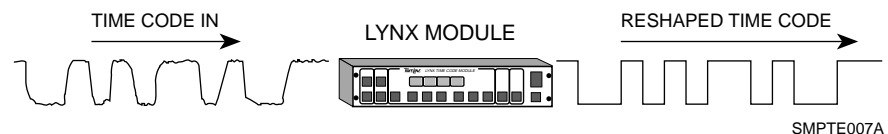
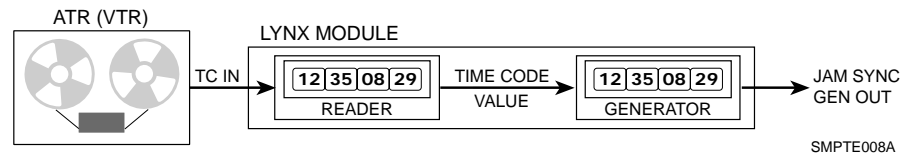

Figure Appendix A-8. Reshaping Time Code

When reshaping, existing code is passed through the reader, which puts out "squared-up" code. If a tape has been copied several times or is very worn, then it is likely that the time code will have dropouts or bad spots that a time code reader will not be able to read. The reshape output of a time code reader can only put out a clean copy of its input. So if the code drops out completely, the reshaped output will have a corresponding dropout. To overcome this, the code must be regenerated rather than reshaped.

## Regeneration or Jam Sync

Jam Sync, is a generator function that is a better alternative to reshaping. It is used to create a new time code that is related to an existing time code on tape. It is extremely useful for repairing a break in an existing time code track, or creating a continuous time code track from an edited or discontinuous track. Code is read up to the last “good” address. Then the generator uses the next consecutive address to generate new code.



**Figure Appendix A-9. Jam Sync**

Jam sync is used extensively in video editing; where different pieces of tape, each with different time code, are spliced together. Jam sync provides the resulting program with continuous time code. TimeLine’s Micro Lynx and Lynx both have manual and automatic jam modes, that quickly and simply let you repair or create new time code tracks to overcome the problems that are detected with bad code.

## About Time Code Readers

A Wide Band Reader, such as the Lynx Time Code Module or Micro Lynx, reads time code even at the high tape speeds used for Fast Forward and Rewind. Wide band reader capabilities are essential, since SMPTE addresses provide the only accurate means of locating positions on tape.

If time code on tape becomes unreadable, the TimeLine readers automatically search for the next best sync source on tape. After SMPTE, the reader searches for serial time code, then pilot tone, and finally tach pulses that are derived from the rotation of the tape machine’s capstan motor.

## Synchronizer Essentials

A synchronizer reads time code from two or more machines; then by manipulating the speed of each machine’s capstan, it forces the two machines to play tape at the same speed. This process is called locking. The Micro Lynx system offers the following synchronization mode.

---

## Phase or Sync Lock

Phase or Sync Lock emulates the old control track or pilot tone method of synchronization. The TimeLine system reads the time codes and synchronizes the transport, taking into account any deliberate offsets. Once the system is locked, the slaves only use the speed information that is derived from the time code, and specific time code addresses are ignored.

This allows the tape machines to stay in lock even if the time code relationships change. The time code change is reported, but the synchronizer makes no corrective action. This is the normal method of operation.

## Advanced Applications

### Video Editing

Video editing is the process of assembling raw footage into a finished television program. Shooting the raw footage is part of what's called television production. Video editing is part of the post-production process. Consider an average television program, perhaps a sitcom or a documentary. The action constantly shifts from one scene to another, moving indoors, outdoors, all over the place. Within a given scene, the perspective also shifts (i.e., from one camera to another, each shooting the scene at a different angle).

In editing, there are multiple video machines, each loaded with footage of different scenes, shot by different cameras. The potential for chaos is great. Fortunately, there's SMPTE time code. Each reel of raw footage is striped with SMPTE, and each frame has a specific and unique location or address. In some cases, both LTC and VITC are on the tape.

During editing, selected scenes of raw footage are transferred onto a master video tape, one after another in sequence, as they will appear in the finished show. The master video tape, as its name implies, contains the master or program time code.

A video editor, locks the source video machines loaded with raw footage to the master video machine. Additionally, one or more audio tape machines may be locked to the master. These contain the production audio: the dialog and incidental sounds recorded during shooting of the raw footage.

Video editing is normally a two-stage operation. First comes offline editing. The person editing the show receives work tapes, i.e., copies of all the raw footage, with time code “burned in” so that it’s visible in one corner of the picture. Any footage initially shot on film, is usually transferred to video at this point. From the work tapes, a basic sequence of scenes is selected. For example, the second scene should be the bar room brawl that occurs, say, between addresses’ 05:40:59:11 and 05:44:12:22 on one of the raw footage reels. In the finished program, this scene needs to start exactly six minutes, five seconds and nine frames (00:06:05:09) into the show and run to 00:09:18:20.

When all the scenes have been sequenced in this manner, an Edit Decision List (EDL) is compiled. The EDL is a complete, computerized directory of the location of the scenes in the show, along with the addresses locating each scene in the raw footage.

Later, when the project moves to online editing, the EDL can be downloaded and the final video master assembled from the original raw footage, which has been pristinely sitting aside while the work tapes endured the rigors of offline editing.

## Audio-For-Video

Just like the raw video footage, all the audio elements that go into a video production must be assembled. This procedure is generally known as audio-for-video or audio post-production. There are several different branches of audio post, since there are many different types of sound sources that go into a typical video show.

First, there’s production audio, which is dialog and sounds recorded during shooting. Often, incidental noises on the set, flubbed lines, and other uncontrollable aspects of the shoot make the production audio unusable. Which brings us to the three main branches of post-production audio.

For dialogue, there’s Automated Dialog Replacement (ADR) in which actors re-record production dialog in the controlled acoustic environment of a sound studio. This replacement dialog is recorded onto audio tape that is locked to a video work print, which the actors carefully watch as they read their lines.

Second, is Foley (named after the man who invented it), the process whereby an abundance of “real-life” sounds, i.e., footsteps, coat zippers, car door slams, etc., are recorded by specialized actors called Foley walkers. They also make their recording while watching a work print that’s synchronized, by SMPTE and a TimeLine synchronizer to an audio tape machine that records the sounds they make.

Third, are sound effects. This is mainly the spectacular stuff – explosions, rocket blasts, gunshots. Today, most sound effects work, as well as some Foley, is created using digital audio samplers. Samplers are devices that can be locked to SMPTE through MTC or MIDI.

Then there's that all-important audio element – music. This is supplied by the composer, who works to rough cuts (preliminary edits) of the finished show and ultimately to the finished video master. The composer may record real instruments onto audio tape that is locked to picture using SMPTE and Lynx modules, or he may work with MIDI instruments that are locked to tape by a Micro Lynx or Lynx System Supervisor.

Ultimately, there are a number of different Audio Tape Machines (ATRs) or film dubbers with the finished music, dialog, and effects. These ATRs are locked to the video master using a TimeLine system controller, such as the Keyboard Control Unit or Console Control Unit. Then the multiple audio sources are balanced by a mixing console to provide a finished audio master for the program. Because this can be quite an elaborate process, many modern post-production facilities use automated mixing consoles, which store mix data, such as fader moves, mutes, etc., in computer memory. These automated systems can also be locked to the video and audio tape machines via the Lynx System Supervisor and Lynx console interfaces.

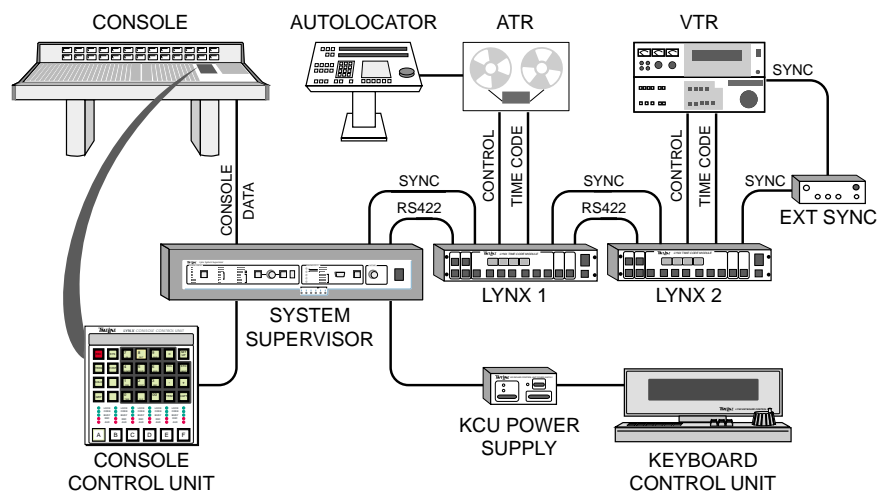

SMPT010A

Figure Appendix A-10. Automated Mixing System

## The Modern Electronic Recording Studio

Today, many record projects and other music recording applications are as elaborate as video post-production, with the number of machines involved and the use of SMPTE time code. Two multi-track tape machines are typically locked together by the Micro Lynx to provide enough audio tracks for instruments and vocals. Some productions require more than two interlocked multitracks. Console fader automation is also the norm for record mix downs, and an absolute necessity for “dance” mixes.

In addition, many projects also involve virtual tracks. Virtual tracks are MIDI synthesizer and drum machine parts that are synchronized to tape, and played back “live” in real time, rather than being recorded onto multitrack. The Micro Lynx provides the all-important SMPTE to MIDI translation.

MIDI is also the protocol used to automate effects processors, such as digital reverbs, harmonizers, etc. These MIDI devices can change programs mid-song, and even perform real time individual parameter changes mid-program. Some mixing consoles, particularly those designed for personal use and project studios also have MIDI automated switching or mixing features.

In short, just about every device in the recording studio – tape machines, consoles, effects processors, and electronic instruments, can now be automated using SMPTE, and MIDI, and the appropriate TimeLine equipment. Thus the Electronic Recording studio is created.

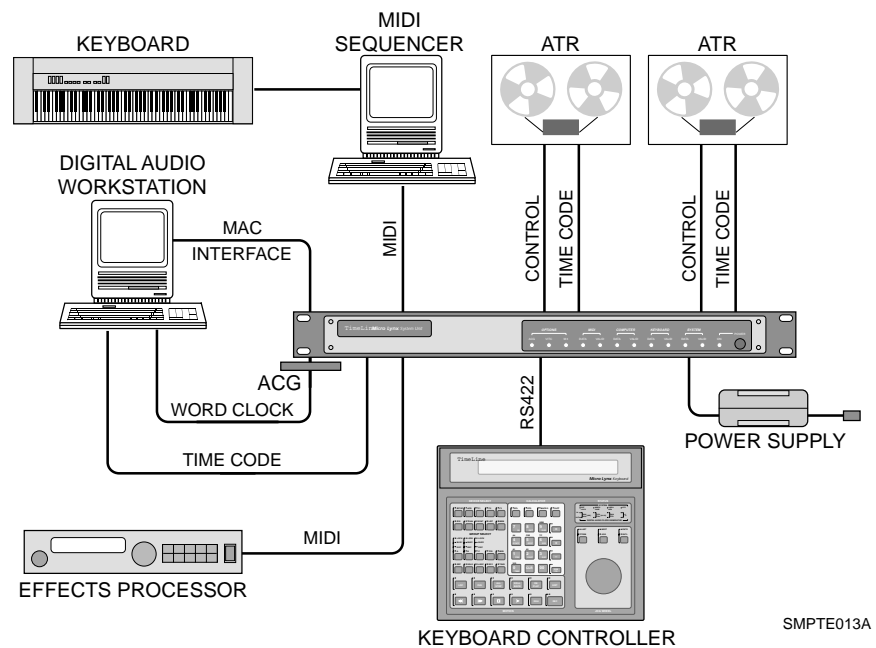

Figure Appendix A-11. The “Modern” Electronic Studio

## SMPTE and the Digital Audio Workstation

The Digital Audio Workstation (DAW) is an important tool for post-production and music recording. The DAW records, edits, manipulates and mixes multiple tracks of audio in a single digital environment. Like the biosphere, it's a self contained, self-sufficient system; but at some point, it must sync with the real world. Digital audio workstations must eventually be slaved to picture or a master tape machine.

This can present a problem. DAWs are always referenced to their own internal sample rate clock. The workstation can use time code to locate and park at a specific SMPTE address. When that address comes up on the master tape, it goes into play; but it's running "wild," locked to nothing but its own internal clock. In short, we're back to something only just a little better than the scenario presented in the beginning: attempting to press two start buttons on two machines at the same time and crossing our fingers.

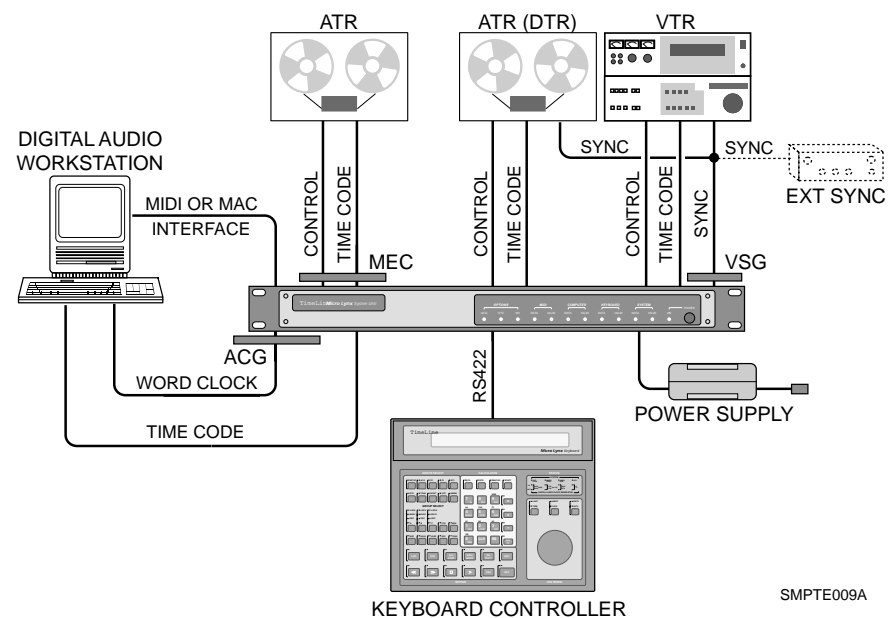

Figure Appendix A-12. Micro Lynx with a Digital Audio Workstation

An excellent solution to the problem is offered by the Micro Lynx Digital Audio Clock Generator (ACG) Card option. It provides a means of referencing the digital audio workstation to the master time code, using word clock (sample rate) data or AES/EBU digital audio bit stream, which contains timing data. The ACG card generates a *digital audio* clock that is locked to the Micro Lynx system reference, and DAW uses it to lock and run its internal sample rate clock.

It's even possible to varispeed the master tape. The Digital Audio Clock Card automatically adjusts the ACGs word clock rate. If the tape speeds up or slows down, the DAW will adjust to match the new play speed (within the limits of the disk system).

As we enter the digital era, time code continues to be an important, practical solution to multiple equipment communication and control.

## The SMPTE Future

SMPTE Time Code and MTC are already being used for applications far beyond their original purpose. Outside the worlds of music recording and video post-production, SMPTE is used to automate light shows at rock concerts, control laser beams at theme park attractions, and trigger flashpot explosions.

Its uses are many and they will continue to grow as time goes on. HOWEVER, the basics of SMPTE will never change. Now that you know them, you're ready for the future.

# Setup Quick Reference

Table Appendix A-2. Setup Quick Reference Guide

[SETUP]	[ACG]	[GRP]	[ROLLBACK, REH, REC]	[TRKS]
[0] NOM S/RATE OUT	[0] ACG OPTION	[0] SEARCH MODE	[ROLLBACK] OR [0] ROLLBACK KEY	[0] VIDEO TRACKS
[+/-] 32,000 Ks/s	[+/-] 44,056 Ks/s	[+/-] CHASE	[+/-] ROLLBACK	[+/-] SAFE
[+/-] 44,100 Ks/s	[+/-] 47,952 Ks/s	[+/-] GROUP	[+/-] PLAY-REV	[+/-] READY
[+/-] 48,000 Ks/s	[+/-] 48,000 Ks/s	[+/-] ON	[REH] OR [1] REHEARSE BY	[1] VIDEO AUTO-RST
[1] VAR RATIO OUT	[+/-] OFF	[1] REF FOLLOW MSTR	[+/-] PLAY+REH	[+/-] OFF
[+/-] OFF	[+/-] ON	[+/-] OFF	[+/-] REH ONLY	[+/-] ON
[2] VAR RATIO OUT %	[+/-] ON	[2] GROUP PARKAHEAD	[REC] OR [2] RECORD BY	[TRAN] MACHINE SELECT
[+/-] 85%-115% (100.00%)	[+/-] ON	[+/-] 0-30 (25)	[+/-] PLAY+REC	[LAST/NEXT] TRANSPORT MFGR
[3] OVERSAMPLE OUT	[+/-] ON	[+/-] NORMAL	[+/-] REC ONLY	[+/-] MACHINE MODEL
[+/-] 128	[+/-] 192	[+/-] TIMECODE	[SYS] SYSTEM OPTIONS	[TRAN] TRAN OPTIONS <sup>2</sup>
[+/-] 256	[+/-] 384	[LOOP] LOOP OPTIONS	[0] LED BRIGHTNESS	[0] CAPSTAN MODE
[+/-] 384	[+/-] 32,000 Ks/s	[0] AFTER EDIT	[+/-] 20%-100% (100%)	[+/-] WILD
[4] NOM S/RATE IN	[+/-] RE-EDIT	[+/-] REPLAY	[1] DSPL CONTRAST	[1] CAPST SPD TRIM
[+/-] 44,056 Ks/s	[+/-] REPEAT	[+/-] REPEAT	[+/-] 30%-100% (70%)	[+/-] -128 TO +127 (0)
[+/-] 44,100 Ks/s	[+/-] STOP	[+/-] RECUE	[2] DSPL TIMEOUT	[2] LIFTER DEFEAT
[+/-] 47,952 Ks/s	[+/-] RECUE	[MACRO] PROGRAM MACRO	[+/-] OFF	[+/-] NEVER
[+/-] 48,000 Ks/s	[+/-] RECUE	[0-9] (1,2,3,8 & 9)	[+/-] 1 MIN	[+/-] NORMAL
[5] VAR RATIO IN	[MEM] MEMORY OPTION	[MEM] MEMORY SIZE	[+/-] 5 MIN	[+/-] NOT STP/PLAY
[+/-] OFF	[0-9] (1,2,3,8 & 9)	[0-9] (1,2,3,8 & 9)	[+/-] 10 MIN	[+/-] ALWAYS
[+/-] ON	[MEM] MEMORY SIZE	[MEM] MEMORY SIZE	[+/-] 20 MIN	[3] RECORD IN
[6] VAR RATIO IN %	[MEM] MEMORY SIZE	[0-9] (1,2,3,8 & 9)	[+/-] NEVER	[+/-] PULSE REC
[+/-] 87.5%-112.5% (100.00%)	[MEM] MEMORY SIZE	[MEM] MEMORY SIZE	[3] JOG SPEED	[+/-] P-REC,PLAY
[7] OVERSAMPLE IN	[MEM] MEMORY SIZE	[MEM] MEMORY SIZE	[+/-] 1-10 (5)	[4] RECORD OUT
[+/-] 128	[MEM] MEMORY SIZE	[MEM] MEMORY SIZE	[4] TRIM FRAME	[+/-] PULSE PLAY
[+/-] 192	[MEM] MEMORY SIZE	[MEM] MEMORY SIZE	[+/-] 01-10 (01)	[+/-] P-REC,PLAY
[+/-] 256	[MEM] MEMORY SIZE	[MEM] MEMORY SIZE	[5] TRIM SUBFRAME	[+/-] PULSE STOP
[+/-] 384	[MEM] MEMORY SIZE	[MEM] MEMORY SIZE	[+/-] 01-25 (01)	[+/-] P-REC,STOP
[+/-] OFF	[MEM] MEMORY SIZE	[MEM] MEMORY SIZE	[6] PORT SELECT	[+/-] P-PLAY,STOP
[8] REFERENCE IN	[MEM] MEMORY SIZE	[MEM] MEMORY SIZE	[+/-] MAC: MIDI, 422:ES	[+/-] PULSE OPTO
[+/-] AES/EBU	[MEM] MEMORY SIZE	[MEM] MEMORY SIZE	[+/-] MAC: ES, 422:OFF	[+/-] SPECIAL OPTO
[+/-] CLOCK IN BNC	[MEM] MEMORY SIZE	[MEM] MEMORY SIZE	[TCG] TCG OPTIONS	[5] REHEARSE IN
[EDIT] EDIT OPTION	[MEM] MEMORY SIZE	[MEM] MEMORY SIZE	[0] SYSTEM REF	[+/-] LATCH REH
[0] EDIT Q/C	[MEM] MEMORY SIZE	[MEM] MEMORY SIZE	[+/-] INTFIX	[+/-] PULSE REH
[+/-] DISABLE	[MEM] MEMORY SIZE	[MEM] MEMORY SIZE	[+/-] INTVAR	[+/-] P-REH,PLAY
[+/-] REPLY	[MEM] MEMORY SIZE	[MEM] MEMORY SIZE	[+/-] EXTVID	[+/-] P-REH,RECLOG
[+/-] STOP	[MEM] MEMORY SIZE	[MEM] MEMORY SIZE	[+/-] AUX	[+/-] L-REH,RECLOG
[1] EDITS ROLL AS	[MEM] MEMORY SIZE	[MEM] MEMORY SIZE	[+/-] VSO MASTER	[+/-] PULSE REC
[+/-] MAST/SLAVE	[MEM] MEMORY SIZE	[MEM] MEMORY SIZE	[+/-] ACG	[6] REHEARSE OUT
[+/-] ALL SLAVES	[MEM] MEMORY SIZE	[MEM] MEMORY SIZE	[1] SYSTEM SPD/CODE	[+/-] UNLATCH REH
[EVENT] SELECT GPI OPTIONS <sup>1</sup>	[MEM] MEMORY SIZE	[MEM] MEMORY SIZE	[+/-] 24 Hz/24	[+/-] PULSE PLAY
[1] GPI 1	[MEM] MEMORY SIZE	[MEM] MEMORY SIZE	[+/-] 25Hz/25 (PAL)	[+/-] SAVE AS REC
[+/-] NORMAL	[MEM] MEMORY SIZE	[MEM] MEMORY SIZE	[+/-] 29.97Hz/DF	[7] APPROACH SPEED
[+/-] AUTOSET	[MEM] MEMORY SIZE	[MEM] MEMORY SIZE	[+/-] 29.97Hz/30 (NTSC)	[+/-] 20-254
[+/-] REC TALLY	[MEM] MEMORY SIZE	[MEM] MEMORY SIZE	[+/-] 30Hz/DF	[8] BANDWIDTH LIMIT
[+/-] EDIT REC	[MEM] MEMORY SIZE	[MEM] MEMORY SIZE	[+/-] 30Hz/30	[+/-] OFF
[+/-] REH TALLY	[MEM] MEMORY SIZE	[MEM] MEMORY SIZE	[2] VARISPEED %	[+/-] ON
[+/-] EDIT REH	[MEM] MEMORY SIZE	[MEM] MEMORY SIZE	[+/-] 87.5%-112.5% (100.00%)	[9] READER MODE
[+/-] LOCK TALLY	[MEM] MEMORY SIZE	[MEM] MEMORY SIZE	[+/-] JOG/SHTL WHEEL = ±0.1%	[+/-] LTC/SER TC
[2] GPI 2	[MEM] MEMORY SIZE	[MEM] MEMORY SIZE	[+/-] [+/-] = ±0.01%	[+/-] LTC/TT1
[+/-] MODE	[MEM] MEMORY SIZE	[MEM] MEMORY SIZE	[3] TCG GROUP MODE	[+/-] SERIAL TC
[+/-] NORMAL	[MEM] MEMORY SIZE	[MEM] MEMORY SIZE	[+/-] PLAY, RUN	[+/-] T.TIMER 1
[+/-] AUTOSET	[MEM] MEMORY SIZE	[MEM] MEMORY SIZE	[+/-] PLAY, MUTE	[00] MUTE CONTROL
[+/-] REC TALLY	[MEM] MEMORY SIZE	[MEM] MEMORY SIZE	[+/-] PLAY, WIND	[+/-] NORMAL
[+/-] EDIT REC	[MEM] MEMORY SIZE	[MEM] MEMORY SIZE	[4] TCG STILL MODE	[+/-] UNTIL RSLVD
[+/-] REH TALLY	[MEM] MEMORY SIZE	[MEM] MEMORY SIZE	[+/-] OFF	[+/-] UNTIL LOCKED
[+/-] EDIT REH	[MEM] MEMORY SIZE	[MEM] MEMORY SIZE	[+/-] ON	[+/-] NOT LOCKED
[+/-] LOCK TALLY	[MEM] MEMORY SIZE	[MEM] MEMORY SIZE	[5] AUX OUTPUT SEL	[NEXT] LOCK THRESHOLD
[1] BEEP MODE	[MEM] MEMORY SIZE	[MEM] MEMORY SIZE	[+/-] PILOT	[+/-] 0-50 (35)
[+/-] OFF	[MEM] MEMORY SIZE	[MEM] MEMORY SIZE	[+/-] RESHAPE 1	[NEXT] LOCK DELAY
[+/-] ON	[MEM] MEMORY SIZE	[MEM] MEMORY SIZE	[+/-] RESHAPE 2	[+/-] 0-50 (10)
[2] BEEP SPACING	[MEM] MEMORY SIZE	[MEM] MEMORY SIZE	[+/-] RESHAPE 3	[NEXT] PARK WINDOW
[+/-] 10-30 (20)	[MEM] MEMORY SIZE	[MEM] MEMORY SIZE	[+/-] GPI-2 BEEP	[+/-] 0-10 (10)
[3] LAST BEEP	[MEM] MEMORY SIZE	[MEM] MEMORY SIZE	[6] VIDEO SYNC GEN	[F3] VITC OPTIONS
[+/-] MUTED	[MEM] MEMORY SIZE	[MEM] MEMORY SIZE	[+/-] OFF	[0] GROUP SELECT
[+/-] ON	[MEM] MEMORY SIZE	[MEM] MEMORY SIZE	[+/-] ON	[+/-] OFF
[RDY] RECORD OPTIONS <sup>2</sup>	[MEM] MEMORY SIZE	[MEM] MEMORY SIZE	[+/-] A	[+/-] A
[0] REC ADV 30-IN	[MEM] MEMORY SIZE	[MEM] MEMORY SIZE	[+/-] B	[+/-] B
[+/-] 0-255	[MEM] MEMORY SIZE	[MEM] MEMORY SIZE	[+/-] C	[+/-] C
[1] REC ADV 30-OUT	[MEM] MEMORY SIZE	[MEM] MEMORY SIZE	[1] READER MODE	[+/-] AUTO
[+/-] 0-255	[MEM] MEMORY SIZE	[MEM] MEMORY SIZE	[+/-] OFF	[+/-] FIXED
[2] REC ADV 15-IN	[MEM] MEMORY SIZE	[MEM] MEMORY SIZE	[+/-] AUTO	
[+/-] 0-255	[MEM] MEMORY SIZE	[MEM] MEMORY SIZE	[+/-] FIXED	
[3] REC ADV 15-OUT	[MEM] MEMORY SIZE	[MEM] MEMORY SIZE		
[+/-] 0-255	[MEM] MEMORY SIZE	[MEM] MEMORY SIZE		
[4] REC ADV 7.5-IN	[MEM] MEMORY SIZE	[MEM] MEMORY SIZE		
[+/-] 0-255	[MEM] MEMORY SIZE	[MEM] MEMORY SIZE		
[5] REC ADV 7.5-OUT	[MEM] MEMORY SIZE	[MEM] MEMORY SIZE		
[+/-] 0-255	[MEM] MEMORY SIZE	[MEM] MEMORY SIZE		

NOTE:  
 ALL KEYS ARE IN BRACKETS [ ].  
 FACTORY DEFAULTS ARE ITALICIZED.  
 1 PRESS EVENT KEY THEN DESIRED GPI NUMBER.  
 2 SELECT RDY OR TRAN, THEN MACHINE (A, B, OR C)  
 TO SETUP OPTIONS.  
 3 USE KEYS 0, 1, 2 ONLY AFTER FIRST SELECTION.



# Cable Reference Guide

**Table Appendix A-3. Cable Reference Guide**

<b>Micro Lynx Transport Control Cables</b>				
<i>TimeLine Part No.</i>	<i>Transport Manufacturer</i>	<i>Machine Model</i>	<i>Setup Menu Description</i>	<i>Cable Type Description</i>
71C062	Accom	WSD	WSD	<b>Micro Lynx Serial</b>
Special Order	AEG	M-20	M-20	<b>M-20</b>
71C065	Akai	ADAM	DR-1200	<b>DR-1200</b>
71385	Alesis	AI2/ADAT	AI2/ADAT	<b>AI2/ADAT</b>
71C037	Ampex	ATR-100	ATR-100	<b>ATR-100</b>
71C038	Ampex	ATR-124	ATR-124	<b>ATR-124</b>
71C039	Ampex	MM-1200	MM-1200	<b>MM-1200</b>
71C062	Ampex	VPR-3 VPR-6 VPR-80 VPR-300	VPR-3 VPR-6 VPR-80 VPR-300	<b>Micro Lynx Serial</b>
71C076	Denon	DN-3603 RA	DN-3603 RA	<b>DEN-3603</b>
	Denon	DN-3603G	DN-3603G 10k	
71C081	Fostex	Model 20	Model 20	<b>Model 20</b>
71C062	Fostex	D-20 RD-8	D-20 RD-8	<b>Micro Lynx Serial</b>
71C040	Fostex	E-2 E-8 E-16 E-22 G-16 G-24	E-16	<b>E &amp; G Series</b>
71C062	JVC	CR-850	CR-850, Ser	<b>Micro Lynx Serial</b>
71C042 or 71C073	JVC	BR-610 BR-611	BRS-610	<b>JVC Type B or JVC Type B (Y Cable)</b>
		BR-810 BR-811	BRS-810	
		BR-5610 BR-5810 BR-8600U BR-7700U	BR-8600 "B" cbl	
		BR-8600E BR-7700E	BR-8600E	
71C043 or 71C070	JVC	CR-5500 CR-6650 CR-8250	CR-8250	<b>JVC Type C or JVC Type C (Y Cable)</b>
Special Order	3M	M-79	M-79	<b>M79</b> (Dealer installation recommended)
71C046	Mitsubishi	X-850	X-850, Capst-Norm X-850, Capst-Rls-Norm	<b>X-850</b>
		X-880	X-880, Capst-Norm X-880, Capst-Rls-Norm	

**Table A-3. Cable Reference Guide (continued)**

<b>Micro Lynx Transport Control Cables</b>				
<b>Timeline Part No.</b>	<b>Transport Manufacturer</b>	<b>Machine Model</b>	<b>Setup Menu Description</b>	<b>Cable Type Description</b>
71C047	Otari	MTR-10/1 MTR-12/1	MTR-10/1 MTR-12/1	<b>MTR-10/12</b> , Series I (20-pin Honda connectors)
71C048	Otari	MTR-90/1	MTR-90/1	<b>MTR-90</b> , Series I (50-pin & 9-pin "D" connector) (Y Cable)
71C064	Otari	MTR-90/2 MTR-90/2 Layback MTR-90/3	MTR-90/2 MTR-90/2 Layback MTR-90/2, Srch-V	<b>MTR-90</b> , Series II (25-pin Honda connector)
71C066	Otari	MTR-100	MTR-100	<b>MTR-100</b>
71C063	Otari	MTR-10/2 MTR-12/2 MTR-20 MTR-15 MX-55 MX-70 MX-80 MX-70 Layback MTR-100 MTR-100V	MTR-10/2 MTR-12/2 MTR-20 MTR-15 MX-55 MX-70 MX-70 MX-70 Layback MTR-100 MTR-100, Srch-V	<b>Otari Type A</b>
		DTR-900/1	DTR-900/1, Capst-Norm DTR-900/1, Capst-Rls	
		DTR-900/2	DTR-900/2, Capst-Norm DTR-900/2, Capst-Rls	
71C049	Otari	MX-5050/3	MX-5050/3	<b>MX-5050 MkIII</b> Series, 16-pin (older machines)
71C050	Otari	MX-5050/3	MX-5050/3	<b>MX-5050 MkIII</b> Series, 34-pin (current machines)
71C051	Otari	MX-5050/3	MX-5050/3	<b>MX-5050 MkIII</b> Series, 34-pin "Y" (current machines) (Y Cable)
71C062	Otari	DTR-90	DTR-90	<b>Micro Lynx Serial</b>
71C062	Panasonic	AG-7750 AG-7700	AG-7750	<b>Micro Lynx Serial</b>
		AJ-D350	AJ-D350	
71C071	Saturn	824	824	<b>824</b> (a.k.a. Soundcraft Saturn)
71C052	Sony	PCM-3402	3402, Par Capst-Norm 3402, Par Capst-Rls 3402, Ser/Par Capst-Norm 3402, Ser/Par Capst-Rls	<b>Sony Type A</b>
		APR-24 APR-5000	APR-24 APR-5000	
No longer available	Sony	BVU-800	BVU-800, Par	<b>BVU-800</b> (Parallel interface)
71C054 or 71C069	Sony	JH-24 JH-114 Late Model JH-16	JH-24 / JH-110	<b>JH-24 or JH-24</b> (Machines with 12-pin "Autolocator" connector) (Y Cable)
71C055 or 71C074	Sony	JH-110 ABC JH-114 Early Model	JH--114	<b>JH-110 or JH-110</b> (Machines with 21-pin "Synchronizer" connector) (Y Cable)
71C056	Sony	PCM-3324	PCM-3324, Capst-Norm-Hi-Prec PCM-3324, Capst-Rls	<b>PCM-3324</b>
		PCM-3324S	PCM-3324s, Capst-Norm-Hi-Prec PCM-3324s, Capst-Rls	
71391	Sony	PCM-7030fm	PCM-7030/fm	<b>PCM-7030 FM</b> (Vari-speed operation)

Table A-3. Cable Reference Guide (continued)

<b>Micro Lynx Transport Control Cables</b>				
<b>TimeLine Part No.</b>	<b>Transport Manufacturer</b>	<b>Machine Model</b>	<b>Setup Menu Description</b>	<b>Cable Type Description</b>
71C075	Sony	VO-5850	VO-5850 int	<b>VO-5850</b> (M3 Card required)
71C062	Sony	PCM-7030 PCM-7050	PCM-7030	<b>Micro Lynx Serial</b>
		VO-9800 VO-9850	VO-9800	
		BVW-10 BVW-40 BVW-75	BVM-10 BVW-40 BVW-75	
		BVU-800	BVU-800, Ser	
		BVU-950	BVU-950	
		BVH-2000 BVH-2800 BVH-3000	BVH-2000	
		DMR-4000	DMR-4000	
		DVR-10/18 DVR-1000	DVR-10 DVR-1000	
		DVW-500 DVW-A500 DVW-510 DVW-A510 DVW-CA510 DVW-CA510	DVW-500	
		UVW-1800	UVW-1800	
Special Order	Stellavox	TD-9	TD-9	<b>TD-9</b>
71C067	Studer	A-807	A-807, Par A-807, Ser/Par	<b>Studer Type B</b>
		A-810	A-810	
		A-812	A-812, Par A-812, Ser/Par	
		A-820 1/2"	A-820 1/2", Par A-820 1/2", Ser/Par	
		A-820 32 Hz	A-820, Par A-820, Ser/Par	
		A-827 32 Hz	A-827 32 Hz Tach, Par A-827 32 Hz Tach, Ser/Par	
		D-820 64 Hz	D-820 64 Hz/48k, Par Capst-Norm D-820 64 Hz/44.1k, Par Capst-Norm D-820 64 Hz/48k, Par Capst-Rls D-820 64 Hz/44.1k, Par Capst-Rls	
		D-827 64 Hz	D-827 64 Hz/48k, Par Capst-Rls D-827 64 Hz/44.1k, Par Capst-Rls	
71C058	Studer	A-80VU	A80VU 16 Hz Tach A80VU 18 Hz Tach	<b>A-80VU</b>
71C059	Studer	A-800/1 A-800/3	A-800/1 A-800/3	<b>A800</b>
71C062	Studer	D-827	D-827	<b>Micro Lynx Serial</b>
71C060	Tascam	40 Series	40 Series	<b>Tascam Type A</b>

Table A-3. Cable Reference Guide (continued)

<b>Micro Lynx Transport Control Cables</b>				
<i>TimeLine Part No.</i>	<i>Transport Manufacturer</i>	<i>Machine Model</i>	<i>Setup Menu Description</i>	<i>Cable Type Description</i>
		ATR-60 ATR-80	60 Series ATR-80	
71C068	Tascam	MSR-16 MSR-24 BR-20T	MSR-16	<b>Tascam Type B</b>
		TSR-8	TSR-8	
71C061	Tascam	50 Series	50 Series	<b>50 Series</b>
71C062	Tascam	DA-88	DA-88	<b>Micro Lynx Serial</b>
		DA-60	DA-60	
Special Order	Tascam	DA-800	DA-800 44.1k DA-800 48k	<b>DA-800</b>

# Auto Serial Transport

A new transport selection labeled "AUTO Serial TRANSPORT" will automatically detect the presence of most serial transports, and load in the appropriate transport parameters. The following table lists the serially controlled transports currently recognized, and shows the transport selection that will be invoked when each transport is found.

Serial Transport	TRAN Selection
Sony BVH-2000	SONY BVH-2000
Sony BVH-2180	SONY BVH-2000
Sony BVH-2500	SONY BVH-2000
Sony BVH-2700	SONY BVH-2000
Sony BVH-2800	SONY BVH-2000
Sony BVH-2830	SONY BVH-2000
Sony BVH-3000	SONY BVH-2000
Sony BVH-3100	SONY BVH-2000
Sony BVU-800	SONY BVU-800s
Sony BVU-820	SONY BVU-800s
Sony BVU-850	SONY BVU-800s
Sony BVU-870	SONY BVU-800s
Sony BVU-900	SONY BVU-950
Sony BVU-920	SONY BVU-950
Sony BVU-950	SONY BVU-950
Sony VO-9800	SONY 9800
Sony VO-9850	SONY 9800
Sony BVW-10	SONY BVW-10
Sony BVW-40	SONY BVW-40
Sony BVW-11	SONY BVW-10
Sony BVW-15	SONY BVW-10
Sony BVW-60	SONY BVW-75
Sony BVW-65	SONY BVW-75
Sony BVW-95	SONY BVW-75
Sony BVW-96	SONY BVW-75
Sony BVW-70	SONY BVW-75
Sony BVW-75	SONY BVW-75
Sony PVW-2600	SONY BVW-75
Sony PVW-2800	SONY BVW-75
Sony PVW-2650	SONY BVW-75
Sony BVW-D75	SONY BVW-75

Serial Transport	TRAN Selection
Sony DVR-1000	SONY DVR-1000
Sony DVR-2000	SONY DVR-1000
Sony DVR-2100	SONY DVR-1000
Sony DVR-10	SONY DVR-10
Sony DVR-18	SONY DVR-10
Sony DVR-20	SONY DVR-10
Sony DVR-28	SONY DVR-10
Sony DVW-500	SONY DVW-500
Sony PCM-3402	SONY 3402 sd
Sony PCM-7030	SONY 7030
Sony PCM-7050	SONY 7030
Sony EVO-9800	SONY 9800
Sony EVO-9850	SONY 9800
Alesis AI2	ALESIS AI2/ADAT
JVC CR-850	JVC CR-850s
JVC CR-600	JVC CR-850 s
Fostex D-20	FOSTEX D-20
Otari DTR-90	OTARI DTR-90
Panasonic AG-7750	PANA AG-7750
Panasonic AJ-D350	PANA AJ-D350
Tascam DA-88	TASCAM DA-88
Ampex VPR-80	AMPEX VPR-80
Ampex VPR-3	AMPEX VPR-3
Ampex VPR-6	AMPEX VPR-6
Ampex XVR-80	AMPEX VPR-80
Ampex VPR-300	AMPEX VPR-300
Ampex VPR-305	AMPEX VPR-300
Ampex VPR-350	AMPEX VPR-300
Ampex VPR-200	AMPEX VPR-300
Ampex VPR-250	AMPEX VPR-300
Ampex DCT-700d	AMPEX VPR-300



# Key and Key Combination Identification Numbers

## Micro Lynx

# on Screen	Stuck Key or Combination
0	0
1	1
2	2
3	3
4	4
5	5
6	6
7	7
8	8
9	9
10	00
11	CLR
12	MINUS (-)
13	PLUS (+)
14	EQUAL (=)
15	STO
16	RCL
17	CAPT
18	SUBFR
19	MACRO
20	TRIM OR LAST
24	A
25	B
26	C
27	TCG
28	MIDI
30	F1
31	F2
32	F3

# on Screen	Stuck Key or Combination
33	SETUP
34	ACG
35	SYS
36	TRAN
37	EVNT
38	LIST
39	MEM
42	GRP
43	SOLO
44	LOOP
45	RDY
46	TRKS
50	LOC
51	CUE
52	ALL STOP
53	ROLLBACK
54	REPLAY
55	EDIT
56	RW (<<)
57	FF (>>)
58	STOP (■)
59	PLAY (>)
60	REH
61	REC
62	JOG OR NEXT
63	SHTL OR ENTR
64	PEDAL
65	CUE + LOC
66	STOP + RW

Appendix

# on Screen	Stuck Key or Combination
67	STOP + FF
68	PLAY + REH
69	PLAY + REC
144	CLR + 0
145	CLR + 1
146	CLR + 2
147	CLR + 3
148	CLR + 4
149	CLR + 5
150	CLR + 6
151	CLR + 7
152	CLR + 8
153	CLR + 9
154	CLR + 00
157	CLR + CUE
158	CLR + EDIT
160	CLR + RDY
161	CLR + SYS
162	CLR + TRAN
163	CLR + TRKS
164	CLR + SETUP
165	GRP + SETUP
166	GRP + SYS
167	MEM + CAPT

# on Screen	Stuck Key or Combination
176	MACRO + 0
177	MACRO + 1
178	MACRO + 2
179	MACRO + 3
180	MACRO + 4
181	MACRO + 5
182	MACRO + 6
183	MACRO + 7
184	MACRO + 8
185	MACRO + 9
192	GRP + A
193	GRP + B
194	GRP + C
195	GRP + TCG
196	GRP + MIDI
200	RDY + A
201	RDY + B
202	RDY + C
208	SETUP + A
209	SETUP + B
210	SETUP + C
211	SETUP + TCG
212	SETUP + MIDI

## Glossary

---

- 24** '24' refers to both the film-standard speed and code type.
- 25** '25' refers to both the EBU/PAL speed and code type.
- 29.97** '29.97' refers to a SMPTE frame rate only, in frames-per-second.
- 30** '30' refers to a SMPTE frame rate only, in frames-per-second.
- Address** SMPTE/EBU time code address. Also referred to as time code value. A specific and unique address in the time code data stream.
- A set of SMPTE or EBU time code numbers indicating a specific position on tape. A complete SMPTE address includes hours, minutes, seconds, and frames.
- ADR** Automated Dialog Replacement. A technique for replacing production dialog in the studio.
- AES/EBU** A professional standard for the high speed transfer of two channels of digital audio data. Developed jointly by the Audio Engineering Society (AES) and the European Broadcast Union (EBU).
- Amplitude** Signal displacement from a zero point. The amplitude of an analog signal is the measurement of voltage increase or decrease.
- Analog Audio** The "traditional" means of recording and reproducing sound, using fluctuating electronic voltages to replicate audio waveforms.
- ATR** Audio Tape Recorder.
- Autolocator** A device that can hold multiple tape locations in memory and chase to those locations on command, using SMPTE addresses, tach pulses, or control track pulses to find a desired point on tape.
- Bandwidth** The frequency range of a signal.
- Binary Numerical System** A system for expressing numerical values using two digits, 0 and 1. The binary system is used in digital audio, SMPTE, MIDI, and other microprocessor-related data formats.

- Biphase Encoding** The way in which SMPTE time code gets encoded onto tape. It expresses binary '1' and binary '0'.  
  
Biphase encoding reverses the signal polarity halfway through a bit to represent a '1' and leaves the bit polarity unchanged to represent a '0'.
- BIT** Short for BInary digiT; a number which is either one or zero.
- Blanking Interval** The blanking interval occurs at the end of a frame. Video information is absent during the blanking interval. The interval occurs when the CRT electron gun scanner goes from the bottom right corner of the screen to the beginning of the next field in the top left corner.
- BNC** Bayonet-Nut Coupler. Used for the connection of video and high frequency clock signals.
- Byte** A group of related binary data or a word, which can be read, interpreted, and acted on by a microprocessor. A byte is made up of bits, which can be either a 0 or 1.
- Capstan** On a tape recorder the motor driven spindle that drives the tape across the heads. A synchronizer controls the capstan motor to keep the tape in sync.
- Code Type** See Time Code Type
- Configuration** See Setup Mode. The process of defining the user-selected operational parameters, such as defining a specific transport or lifter-defeat mode.
- Control Track** A synchronizing signal on the edge of a tape, which provides a reference for tracking control and tape speed.
- CPU** Central Processing Unit. A computers central microprocessor, responsible for all system logic and memory organization.
- DAW** Digital Audio Workstation. Usually refers to a computer-based, hard disk recording and editing environment.
- Decibel (dB)** The unit of measurement used to describe a sounds amplitude. The measurement is relative and logarithmic.
- DF** Drop frame. See drop frame
- Differential Input** Input amplifier that is designed to amplify the difference between two signals and reject common signals.
- Differential Output** Output amplifier designed to provide two signals that are completely identical but with opposite phase.

- Digital** Literally “using digits”. A Computer is a typical digital device.
- Digital Audio** Audio signal that has been converted (digitized) into a stream of binary numbers for storing or transmitting, that are equivalent to the original analog audio signal.
- Display** Numeric display. Time Code/Message Display.
- Drop Frame** Drop frame is one of the two SMPTE code types, and is the NTSC color television standard. When using this code type, 108 specific frame numbers are “dropped” for each hour of time code. See the Appendix for more detailed time code information.
- EBU** EBU time code is a 25-frame code running at 25 fps.
- Edit Decision List (EDL)** A list, either on paper or in computer memory, of time code addresses indicating successive scenes of source video footage that make up a complete program.
- EDL** See Edit Decision List.
- ERR** Error or offset error. Indicates that the display shows the difference between the actual position of the machine in relation to where the system expects it to be.
- EXT VID** A source of external video sync used by the synchronizer as a timing reference. Can be color black, black burst, color bars or composite sync.
- Filter** A digital or analog process which has the effect of removing unwanted frequencies from an audio signal.
- Foley** The process of adding incidental sounds, such a footsteps, door slams, etc., to a video program or motion picture.
- Format** See Time Code Format.
- Frame** A single image on a motion picture film or a television picture formed from two interlaced fields. One complete video scanning cycle, one complete SMPTE time code word.
- Frame Lock** Frame lock maintains synchronization between the Master and Slave transports, using the position information available in the time code address.
- Frame Rate** The number of frames that go by in one second of audio, film or video tape. Film and different types of video all have different frame rates.
- 30      30 fr/s      Monochrome TV, & audio

NTSC	29.97 fr/s	Color videotape, TV operations
PAL	25 fr/s	European TV, European Broadcast, & audio
Film	24 fr/s	Film cameras & projectors

- Frequency** The number of wave cycles that occur in a given period of time (one second). The unit of measurement is the Hertz (Hz).
- Generate** Running the system time code generator so that time code is available at the rear panel GEN OUT jack.
- Generator** A time code generator. Each synchronizer has a time code generator. This generator receives its speed reference from one of the internal or external sources.
- GEN REF** Generator reference. May also be referred to as reference source.
- Groups** A group of machines that have a defined positional relationship. Machines are placed in group mode for synchronization. Machines in a group will operate together as if they were a single transport.
- GRP** See Groups.
- Guard Band** A track of multitrack tape adjacent to the sync track (such as SMPTE or Control Track), which is left unrecorded in order to prevent the time code from bleeding onto the audio program material.
- HH:MM:SS:FF** Hours:Minutes:Seconds:Frames. A SMPTE time code address or value.
- Initialize** Completely clear the synchronizers RAM. Press and hold the CLR key while you power-up the module.
- INT XTAL** A system speed reference that is derived from the unit's internal crystal. This reference should be selected when an external reference (video or word clock) is not required.
- Jam Sync** A technique used to start a time code generator from another running time code. It can be used to recreate missing time code or to external existing time code on tape.
- Jam Time Code** The Jam Time Code or Jam Sync function. See Jam Sync.
- KCU** Keyboard Control Unit. TimeLine's external machine control unit. The KCU provides centrally-controlled access to all synchronizers in a system.
- LCD** Liquid Crystal display. The KBD display is of this type.
- LED** Light emitting diode.
- Lifter** A tape transport's head lifter mechanism. Tape machines

normally lift the tape off the heads when in wind (FFW/RWD). The synchronizer intelligently controls the machines lifter operation, to read time code when required.

- Local Transport** The machine or transport that the synchronizer is connected to and controlling.
- Lock** The transport is synchronized with the system reference GEN REF.
- LTC** Longitudinal Time Code. Time code information encoded in binary coded decimal (BCD) form which is recorded as an audio signal on a designated track of a VTR or an ATR.
- Machine** Machine refers to the generic concept of tape record/playback hardware.
- Machine Control** The wide ranging field of transport control. This covers basic transport operation, synchronization and more complex functions such as electronic editing.
- MACROS** Preprogrammed or user programmed keys permitting complex key sequences to be stored and executed by pressing a single key. Sometimes known as smart keys.
- MIDI** Musical Instrument Digital Interface. This serial data language is used by microprocessors in synthesizers, sequencers, drum machines, signal processors, and computers. It provides musical pitch and rhythm information, synthesizer performance parameters, song position markers, stop/start/continue commands for sequencers and computers, and synchronizing data called MIDI Clock, which is based on 24 pulses per quarter-note. MIDI is frequently used with SMPTE for sync-to-tape functions.
- MIDI is transmitted between microprocessors at 32.125 kBits per second. It can also be used by lighting systems and mixing consoles.
- MIDI Time Code** A MIDI system real time message that assigns a unique address for a specific moment in time. MIDI Time Code takes two frames to transmit a complete address in bursts of data that are transmitted every 1/4 frame.
- Motion Controls** The basic set of six transport control keys (Play, Stop, Rec, Reh, Rwd & FF) and the six additional transport control functions (Loc, Cue, Allstop, Rlb, replay & Edit).
- MTC** See MIDI Time Code.
- Multitrack** A tape machine, analog or digital which has more than two audio tracks.
- N/A** Not available. Not active. Not applicable.

- Non Drop Frame** NDF or ND is one of the two SMPTE code types and is the black & white television standard. When using this code type, every frame of time code is counted in real time. See the Appendix for more time code information.
- Non-contiguous** Not a continuous, predictable sequence. i.e., 1, 2, 4, 5, 6, 8, 9 is a non-contiguous number sequence.
- NTSC** A system of coding color information for television transmission used primarily in the USA and Japan. Named after the National Television System Committee.
- Offset** Offset is the difference between two time codes at the point at which they are to be synchronized. Offsets are subframe-accurate and are displayed using the HH:MM:SS:FF format. Offsets are always applied to the slave machines.
- Oversampling** A process by which a computer interpolates between adjacent digital audio numbers to provide in-between values and reduce quantization error.
- PAL** Phase Alternate Line. PAL is another name for the 25 time code format, which is the standard for European color and B&W television.
- Phase Lock** A mode of synchronizer operation that uses phase information derived from SMPTE time code and, after initial synchronization, ignores specific frame addresses. It is also called Sync Lock.
- Pilot Tone** The Pilot output signal is a sinusoidally-shaped output, which is always two times the frame rate of the time code that is being referenced or generated.
- Post-production** Activities that take place after the raw footage has been shot for a video program or motion picture. Includes video editing and a number of audio processes, such as ADR, Foley, and mixing.
- Production** The initial stages in the making of a film or television program, which includes the shooting of raw footage and recording of production audio.
- RAM** Random Access Memory. The module's configuration parameters are stored in battery-backed RAM. And recalled each time the unit is turned on.
- Rate** Frame rate or speed. See Frame Rate or Speed.
- REF SRC** Reference source. The signal that is used to determine the rate that the generator and synchronizer will run at. The reference source can be thought of as the system time base. The reference source can be internal crystal, external video, MAINS, or external

pilot tone or the time code reader (VSO).

- Register** The generator register is the module's memory buffer that holds numeric time code values that are entered or captured. Each synchronizer also has reader, sync point, offset, user bit and error registers.
- Reshape** The output signal is the same as the input signal, but it has been reshaped with correct rise time values and a fixed voltage output. This type of output does not correct for bit or timing errors.
- Resolving** A technique for regulating the play speed of a tape machine by matching the rate of pulses recorded on tape with a pulse rate from another stable source or a master tape machine.
- RLB** See Rollback.
- Rollback** The rollback function is used to rewind machines by a predetermined amount from the current position. The default rollback time is 15 seconds.
- S-PDIF** A consumer standard similar to AES/EBU for the high speed transmission of digital audio data. Jointly developed by Sony and Philips.
- Sequencer** A device that can record performance data for synthesizers and other electronic instruments and then, on playback, pass that data on to the instruments so that they'll play what has been recorded. Modern sequencers use MIDI as their communications protocol.
- Serial** A type of computer interface where all data is sent down a single wire or pair of wires one bit at a time. Examples of serial interfaces are RS422 & RS232.
- Serial Port** The physical computer connection through which serial data is transmitted and received.
- Setup Mode** The process of defining the user-selected operational parameters, such as defining a specific transport or lifter-defeat mode.
- Shuttle** Fast-wind. Fast-forward or Rewind.
- SMPTE** Society of Motion Picture and Television Engineers. An industry standards committee. The group responsible for developing SMPTE time code.
- SOLO** Literally "using alone". A tape transport in solo will be controlled by itself, without affecting other transports in the system.
- Speed** Speed, Frame Rate and Rate are synonymous. Time code speed is counted in frames-per-second (fps). SMPTE time code has two speeds: 30 fps and 29.97 fps.

- SU** See System Unit
- SUBF UBITS** Sub frame user bits.
- Sync Lock** See Phase Lock.
- Sync Word** Included at the end of every 80-bit time code word is a 16-bit Sync Word. The sync word provides direction and Phase-lock speed information, and marks the end of each time code word.
- Synchronizer** A device that reads time codes recorded on two or more tape machines, compares the codes, and adjusts the machine's tape positions and speeds based on the results of that comparison.
- System BUS** When two or more synchronizers are used to form a system, a communications link must be established between the modules. This is done by looping from one module to the next, via the RS422 ports on the rear panel of the system unit.
- System Unit** The rack mounting part of the Micro Lynx machine control system. The unit contains the control (CP) and machine control (MC) microprocessors.
- TCA** Time Code Address. The HH:MM:SS:FF bits of the TC word.
- TCG** See Time Code Generator.
- Time Code Format** Time code format defines both the frame rate and code type being used. Example: To describe a time code format as 30 NDF is to say that the frame rate is 30 fps and the code type is non-drop frame. Simply saying either 30 or drop frame defines only part of the SMPTE time code.
- Time Code Generator** A special signal generator designed to generate and transmit SMPTE time code at one of the international formats and rates.
- Time Code Reader** A counter designed to read and display SMPTE time code.
- Time Code Type** The word "type" is the key to understanding this phrase. *Type* defines the counting method that is employed by the time code module. There are two SMPTE types: 30 (also called non-drop "ND" or non-drop frame "NDF") and drop frame (DF). EBU and film types are the same as their respective speeds, 25 and 24.
- Toggle** To toggle is to consecutively press a key several times in order to step through a series of choices.
- Track** A place for the storage of audio information. Analog tape recorders have one or more physical tape tracks. MIDI sequencers and digital audio workstations provide areas of memory to store

- control or audio data.
- Track Select** The process of enabling (arming) specific tape machine tracks for recording.
- Transport** Transport refers to a part or subassembly of a machine, i.e., a transport connector or a transport cable.
- TRS** Tip - Ring - Sleeve. A 1/4", balanced termination plug or jack. Typically wired T = +, R = -, S = shield.
- Type** See Time Code Type.
- UB** See User Bit.
- User Bit** Each time code frame or word consists of 80 bits that convey SMPTE/EBU time code information. Thirty-two of those bits are user bits, and are available for storing information such as IDs, reel numbers, session dates or another time code number.
- Value** Values are generally time code addresses. They may also be a custom user bit IDs.
- Video Sync** A reference video signal generated by an extremely stable source. This signal is used to control the speed of video machines, digital audio machines and is used as a timing reference to ensure accurate synchronization.
- Virtual Tracks** Used to describe any circumstance whereby the method for reproducing audio tracks is not directly analogous to the linear tape track format. Hard disk systems (DAW's) and MIDI sequencers are typical examples.
- MIDI performance commands can be stored in a sequencer. Because the sequencer can "play" these parts in real time, synchronized to tape, they can be regarded as extra or "virtual" tracks, not on the tape, but present nonetheless.
- VITC** Vertical Interval Time Code. An alternative to the LTC format of SMPTE time code. It is recorded in the blanking interval of the video signal, which is not used for the picture.
- VSO** Variable Speed Override. Variable Speed Oscillator.
- VTR** Video Tape Recorder.
- Wideband** A signal that is distributed over most or all of the frequency spectrum. A wide band input amplifier is capable of processing signals that are well outside the audio bandwidth.
- Word Clock** An extremely stable synchronization signal that is used to control

the rate at which digital audio data is converted or transmitted.

**Workstation** See DAW.